



---

***1/4 inch VGA class Analog / Digital Output  
NTSC/PAL CMOS Image Sensor***

---

**PC1030D**

*6<sup>th</sup> Floor, Gyeonggi R&DB Center, 906-5 Iui-dong, Yeongtong-gu, Suwon-si, Gyeonggi-do, 443-766, Korea  
Shenzhen Sales: Tel : 86-755-8304 5321, 86-138 232 78789 , [www.sunnywale.com](http://www.sunnywale.com) ,  
[awin@sunnywale.com](mailto:awin@sunnywale.com)*

***Copyright © 2010, Pixelplus Co.,Ltd  
ALL RIGHTS RESERVED***

**1/4 inch VGA class Analog / Digital Output  
NTSC/PAL CMOS Image Sensor**

**► Features**

- ▷ 648 x 488 effective pixel array with RGB Bayer color filters and micro-lens and optical black pixel
- ▷ Power supply  
AVDD : 2.8V, CVDD : 2.8V, DVDD : 1.8V  
HVDD : 2.8V ~ 3.3V
- ▷ Output formats
  - CVBS (NTSC/PAL)
  - ITU-R. BT601/656 (interlaced, 60 fields @ 27Mhz) with CVBS
  - 320x240(288) YCbCr422 (30(25)fps @ 27Mhz) with CVBS
  - 640x480 (VGA) YCbCr422 digital output only (30fps @ 27Mhz)
- ▷ Image processing on chip  
Lens shading, Gamma/Defect/Color correction, Low pass filter, Color interpolation, Saturation, Edge enhancement, Brightness, Contrast, Auto black level, Auto white balance, Auto exposure control and Back light compensation
- ▷ Frame size, window size and position can be programmed through a 2-wire serial interface bus
- ▷ VGA / QVGA / QQVGA / CIF / QCIF Scaling
- ▷ 50Hz, 60Hz flicker automatic cancellation
- ▷ High Image Quality and High low light performance

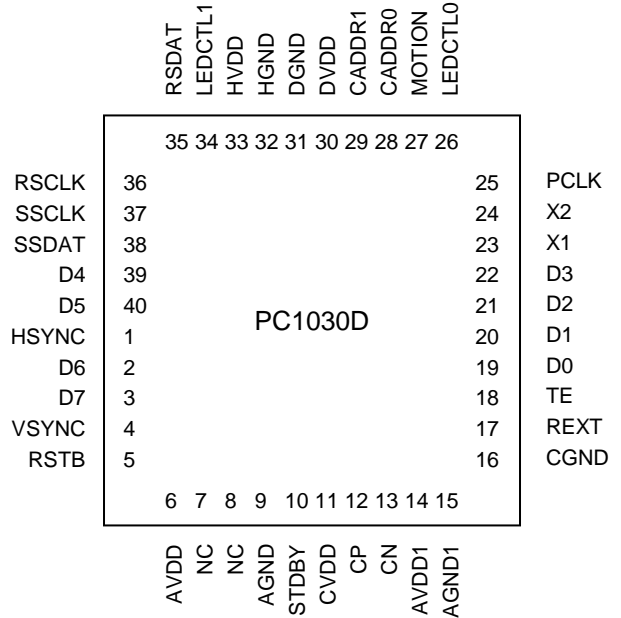

[Fig. 1] PIN Description

<b>Effective Pixel Array</b>	648(H) x 488(V)
<b>Pixel Size</b>	5.55 um x 5.55 um
<b>Effective Image Area</b>	3596.4 um x 2708.4 um
<b>Optical Format</b>	1/4 inch
<b>Max. Clock frequency</b>	27 MHz
<b>Max. Frame Rate</b>	60/50 field/sec @ 27Mhz
<b>Dark Signal</b>	47.9 [mV/sec] @ 60°C
<b>Sensitivity</b>	3.16 [V/Lux.sec]
<b>Power Consumption</b>	213 [mW] @ Dynamic
	19.2 [uW] @ Standby
<b>Operating Temp.</b> (Fully Functional Temp.)	- 40 ~ 105 [°C] @ AT
	- 30 ~ 80 [°C] @ CT
<b>Dynamic Range</b>	63.5 [dB] @ 60°C
<b>SNR</b>	45.6 [dB] @ 60°C

[Table 1] Typical Parameters

**1/4 inch VGA class Analog / Digital Output  
NTSC/PAL CMOS Image Sensor**

▶ **Signal Environment**

PC1030D has 3.3V tolerant Input pads. Input signals must be higher than or equal to HVDD but cannot be higher than 3.3V. PC1030D input pad has built in reverse current protection circuit, which makes it possible to apply input voltage even if the HVDD is disconnected or floating. Voltage range for all output signals is 0V ~ HVDD.

▶ **Chip Architecture**

PC1030D has 648 x 488 effective pixel array and column/row driver circuits to read out the pixel data progressively. CDS circuit reduces noise signals generated from various sources mainly resulting from process variations. Pixel output is compared with the reset level of its own and only the difference signal is sampled, thus reducing fixed error signal level. Each of R, G, B pixel output can be multiplied by different gain factors to balance the color of images in various light conditions. The analog signals are converted to digital forms one line at a time and 1 line data are streamed out column by column. The Bayer RGB data are passed through a sequence of image signal processing block and pre-encoder and encoder blocks to produce YCbCr 4:2:2 output data or composite output. Image signal processing includes such operations as gamma correction, defect correction, low pass filter, color interpolation, edge enhancement, color correction, contrast stretch, color saturation, white balance, exposure control and back light compensation. Internal functions and output signal timing can be programmed simply by modifying the register files through 2-wire serial interface.

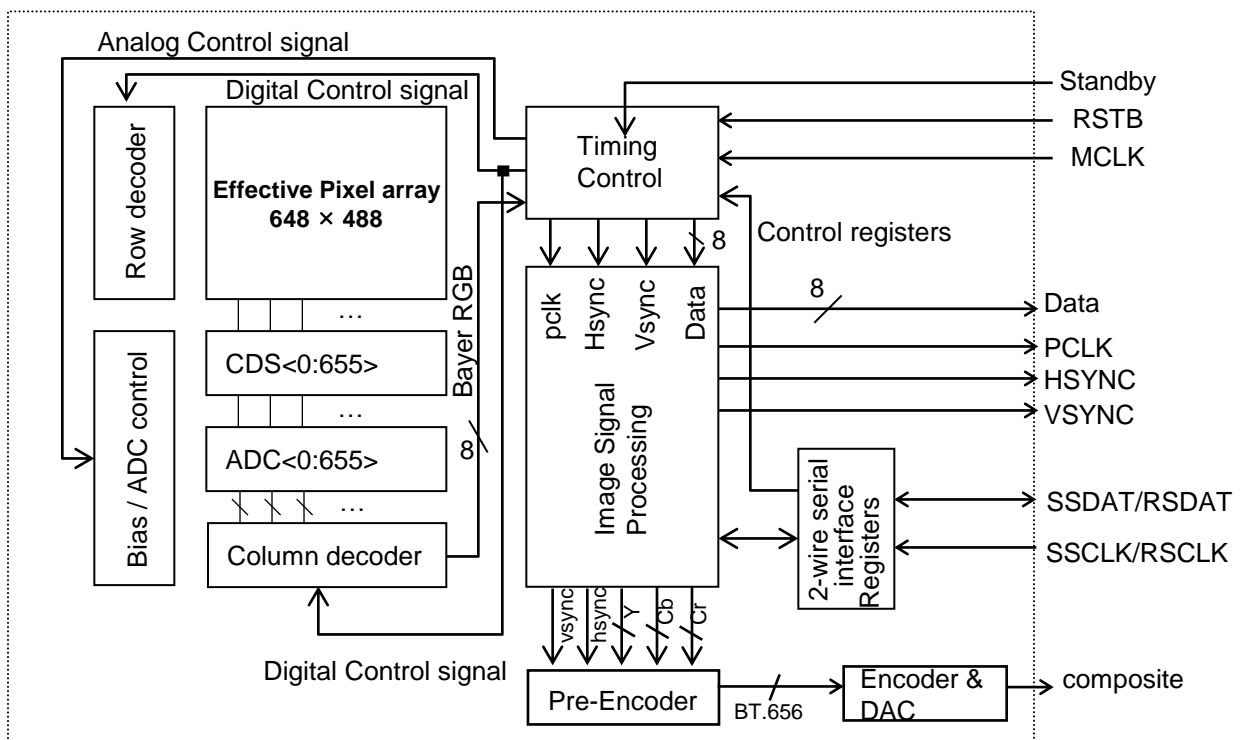

[Fig. 2] Block Diagram