

AR0221

AR0221 1/1.7-Inch CMOS Digital Image Sensor

ON Semiconductor AR0221 is a 1/1.7-inch CMOS digital image sensor with a 1928 H x 1088 V active-pixel array. This advanced image sensor captures images in either linear or line-interleaved high dynamic range, with rolling-shutter readout. AR0221 is optimized for both low light and challenging high dynamic range scene performance with 4.2 μm BSI pixels. The sensor includes flexible functions such as in-pixel binning, windowing, and both video and single frame modes. The device is programmable through a simple two-wire serial interface, and supports both MIPI and HiSPi output interfaces.

Table 1. KEY PARAMETERS

Parameter	Value	
Optical Format	1/1.7 inch (9.298 mm, Diagonal)	
Active Pixels	1928 (H) x 1088 (V), 16:9	
Pixel Size	4.2 μm x 4.2 μm BSI	
Chief Ray Angle	0° (See Note)	
Color Filter Array	RGB Bayer	
Shutter Type	Electronic Rolling Shutter	
Input Clock Range	6–50 MHz	
Output Clock Maximum	80 MHz	
Output Interface	4/2-lane MIPI/HiSPi	
Frame Rate, 1080p	60 fps, Linear Mode 30 fps, 3-exposure line-interleaved HDR	
Responsivity	58.89 Ke-/lux*s	
SNR _{MAX}	41.2 dB	
Maximum Dynamic Range	66 dB, Linear Mode 122 dB, 3-exposure LIM HDR, estimated	
Supply Voltage	I/O	1.8 or 2.8 V
	Digital	1.2 V
	Analog	2.8 V
	MIPI	1.2 V
Power Consumption (Typical)	300 mW, 1080p 60fps Linear Mode, HiSPi 284 mW, 1080p 60fps Linear Mode, MIPI 369 mW, 1080p 30fps 3-exposure LIM HDR, HiSPi 365 mW, 1080p 30fps 3-exposure LIM HDR, MIPI	
Operating Temperature	-30°C to +85°C (Junction)	
Package Options	87-IBGA 12 x 9 mm	

NOTE: Accommodates lens CRA up to 20°.

Features

- High Performance 4.2 μm Backside Illuminated (BSI) Pixel with DR-Pix™ Technology



ON Semiconductor®

www.sunnyvale.com

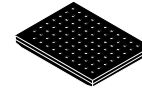

**IBGA87 12 x 9
CASE 503BR**

ORDERING INFORMATION

See detailed ordering and shipping information on page 2 of this data sheet.

This document, and the information contained herein, is CONFIDENTIAL AND PROPRIETARY and the property of Semiconductor Components Industries, LLC., dba ON Semiconductor. It shall not be used, published, disclosed or disseminated outside of the Company, in whole or in part, without the written permission of ON Semiconductor. Reverse engineering of any or all of the information contained herein is strictly prohibited.
© 2018, SCILLC. All Rights Reserved.

Features (continued)

- Advanced Line-Interleaved HDR with Flexible Exposure Ratio Control
- Fast Full Resolution Video Capture of 1928 x 1088 at up to 60 fps in linear mode and 30 fps in 3-exposure HDR
- Data Interfaces: 4-lane MIPI CSI-2 and HiSPi SLVS
- Selectable Automatic or User Controlled Black Level Control
- Frame to Frame Switching Among 2 Contexts to Enable Multi-function Systems
- Spread-spectrum Input Clock Support
- Multi-Camera Synchronization Support
- These are Pb-Free Devices

Applications

- “Starlight” and “Long Range View” Security Camera
- High Dynamic Range Imaging

ORDERING INFORMATION

Table 2. AVAILABLE PART NUMBERS

Part Number	Product Description	Orderable Product Attribute Description
AR0221SRSC00SUEA0-DPBR	2 MP 1/1.7" Image Sensor, RGB, 0° CRA, iBGA87 Package	AR coating and protective film
AR0221SR2C00SUEA0-DRBR	2 MP 1/1.7" Image Sensor, RGB, 0° CRA, iBGA87 Package	AR coating and No Protective Film
AR0221SR2C00SUEAH3-GEVB	Demo3 Headboard, HiSPi/MIPI Output	Headboard

1. Contact the ON Semiconductor sales or marketing representative to discuss your specific requirements.

See the ON Semiconductor *Device Nomenclature* document (TND310/D) for a full description of the naming convention used for image sensors. For reference documentation, including information on evaluation kits, please visit our web site at www.onsemi.com.

GENERAL DESCRIPTION

The ON Semiconductor AR0221 can be operated in its default mode or programmed for frame size, exposure, gain, and other parameters. The default mode output is a 1928 x 1088 resolution image at 60 frames per second (fps). In linear mode, it outputs 12-bit raw data, using serial MIPI or HiSPi output port. In high dynamic range mode, it outputs 12-bit line-interleaved data using the MIPI or HiSPi port. The device may be operated in video (master) mode or in single frame trigger mode.

FRAME_VALID, LINE_VALID and pixel clock can be programmed to output by GPIO pins in serial mode.

The AR0221 includes additional features to allow application-specific tuning: windowing and offset, auto black level correction, and on-board temperature sensor.

Optional register information and histogram statistic information can be embedded in first and last two lines of the image frame.

The sensor is designed to operate in a wide temperature range (-30°C to +85°C Junction).

FUNCTIONAL OVERVIEW

The AR0221 is a progressive-scan sensor that generates a stream of pixel data at a constant frame rate. It uses an on-chip, phase-locked loop (PLL) that can be optionally

enabled to generate all internal clocks from a single master input clock running between 6 and 50 MHz. The maximum output pixel rate is 80 MHz. Figure 1 shows a block diagram of the sensor.

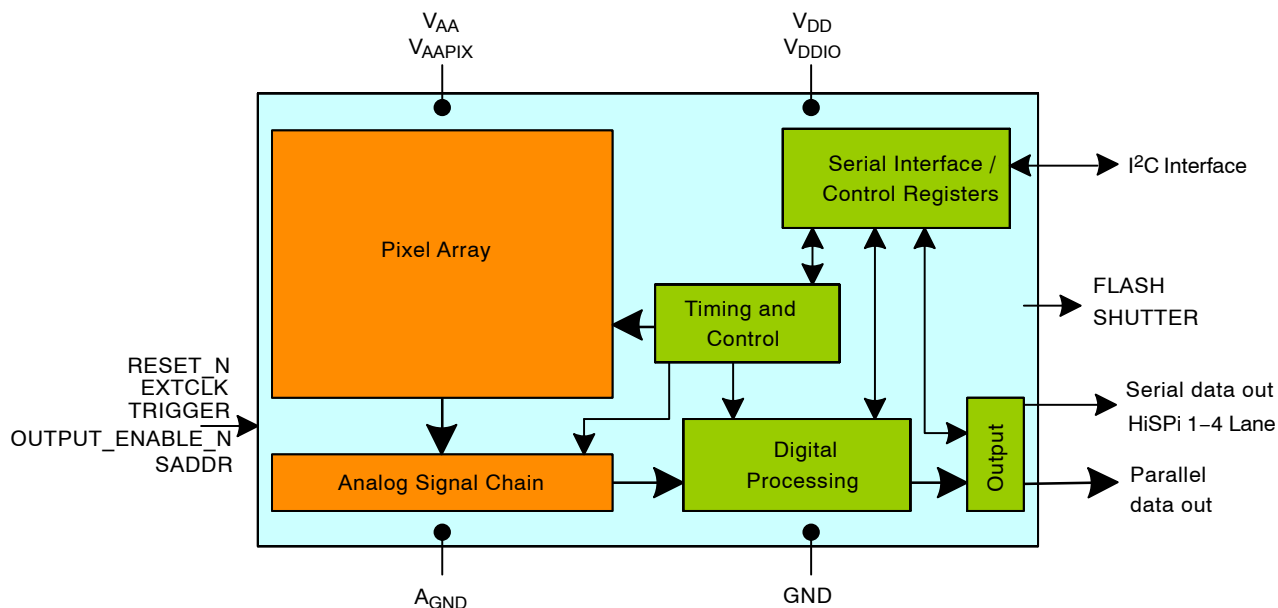

Figure 1. Block Diagram

User interaction with the sensor is through the two-wire serial bus, which communicates with the array control, analog signal chain, and digital signal chain. The core of the sensor is a 2.1 Mp BSI Active-Pixel Sensor array. The timing and control circuitry sequences through the rows of the array, resetting and then reading each row in turn. In the time interval between resetting a row and reading that row, the pixels in the row integrate incident light. The exposure is controlled by varying the time interval between reset and readout. Once a row has been read, the data from the columns is sequenced through an analog signal chain (providing offset correction and gain), and then through an analog-to-digital converter (ADC). The output from the ADC is a 12-bit value for each pixel in the array. The ADC output passes through a digital processing signal chain (which provides further data path corrections and applies digital gain). The sensor also offers a line-interleaved high dynamic range mode of operation where multiple images of different exposures are output separately. The off-chip ISP could combine these images into a HDR image. The pixel data are output at a rate of up to 80 MHz.

Features Overview

The AR0221 has a wide array of features to enhance functionality and to increase versatility. A summary of features follows.

- Operating Modes

The AR0221 works in master (video), trigger (single frame), or Auto Trigger modes. In master mode, the

sensor generates the integration and readout timing. In trigger mode, it accepts an external trigger to start exposure, and then generates the exposure and readout timing. The exposure time is programmed through the two-wire serial interface for both modes

- Window Control

Configurable window size and blanking times allow a wide range of resolutions and frame rates. Digital binning and skipping modes are supported, as are vertical and horizontal mirror operations

- Context Switching

Context switching may be used to rapidly switch between two sets of register values

- Gain

The AR0221 can be configured for dual conversion gain, analog gain of up to 8x, and digital gain of up to 16x

- MIPI

The AR0221 image sensor supports 4/2-line MIPI CSI-2 D-PHY

- HiSPi

The AR0221 image sensor supports 4/2-line HiSPi SLVS

- PLL

An on-chip PLL provides reference clock flexibility and supports spread spectrum sources for improved EMI performance

- Reset
The AR0221 may be reset by a register write, or by a dedicated input pin
- Output Enable
The AR0221 output pins may be tri-stated using dedicated register bits
- Temperature Sensor
- Black Level Correction
- Row Noise Correction
- Test Patterns
Several test patterns may be enabled for debug purposes. These include a solid color, color bar, fade to gray, and a walking 1 s test pattern

optically black and are used internally to monitor black level. There are 1928 columns by 1088 rows of optically active pixels. While the sensor's format is 1920 x 1080, the additional active columns and active rows are included for use when horizontal or vertical mirrored readout is enabled, to allow readout to start on the same pixel. The pixel adjustment is always performed for color versions. The active area is surrounded with optically transparent dummy pixels to improve image uniformity within the active area. Not all dummy pixels or barrier pixels can be read out. The optical center of the readable active pixels can be found between X_ADDR 967 and 968, and between Y_ADDR 547 and 548.

Pixel Array

The AR0221 pixel array is configured as 1936 columns by 1096 rows (see Figures 2 and 3). The dark pixels are

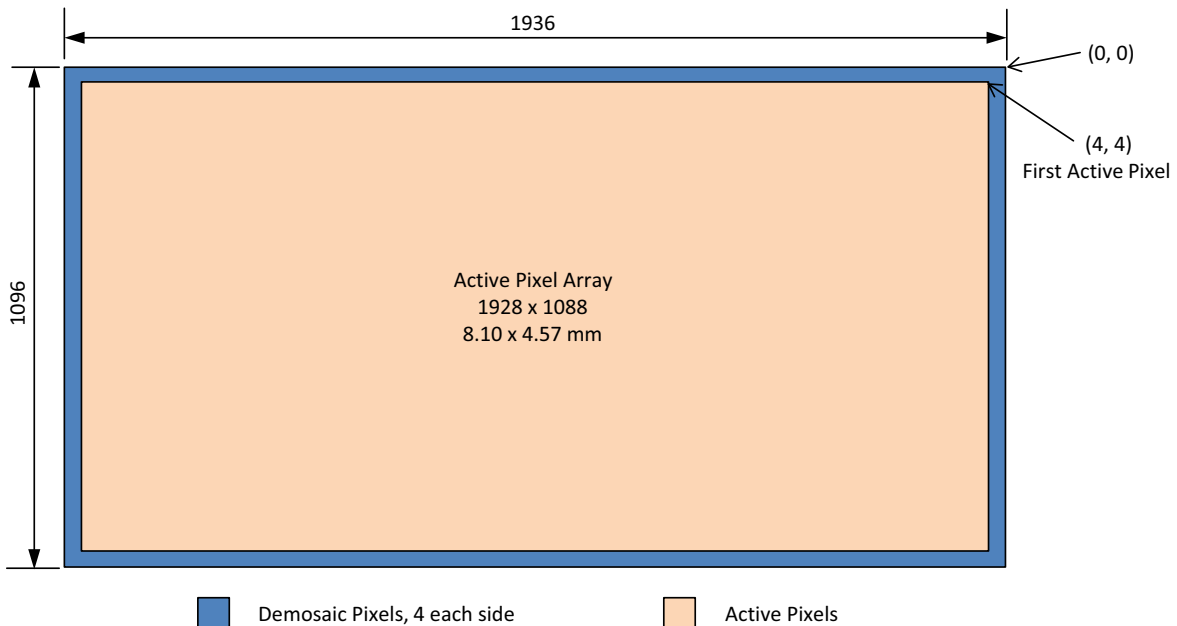

Coordinate: (X_ADDR_START, Y_ADDR_START)

Figure 2. Pixel Array Description

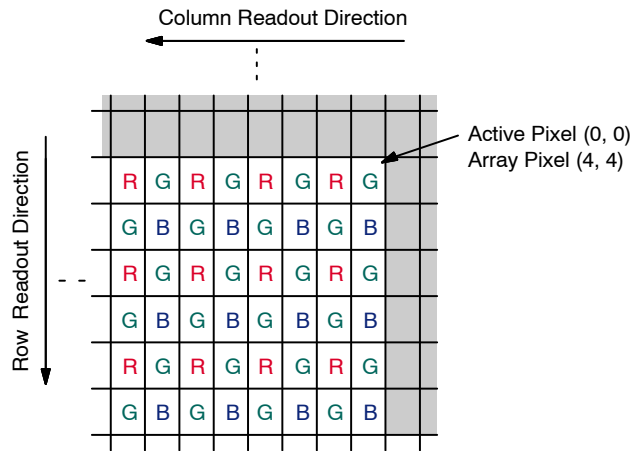

Figure 3. Pixel Color Pattern Detail (Top Right Corner)

Default Readout Order

By convention, the sensor core pixel array is shown with pixel (0,0) in the top right corner (see Figure 3). This reflects the actual layout of the array on the die.

When the sensor is imaging, the active surface of the sensor faces the scene as shown in Figure 4. When the image is read out of the sensor, it is read one row at a time, with the rows and columns sequenced as shown in Figure 4.

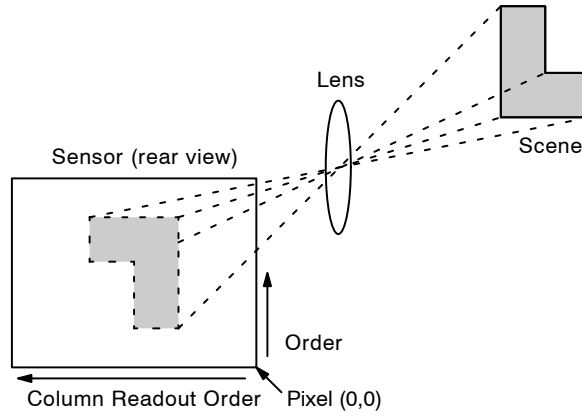
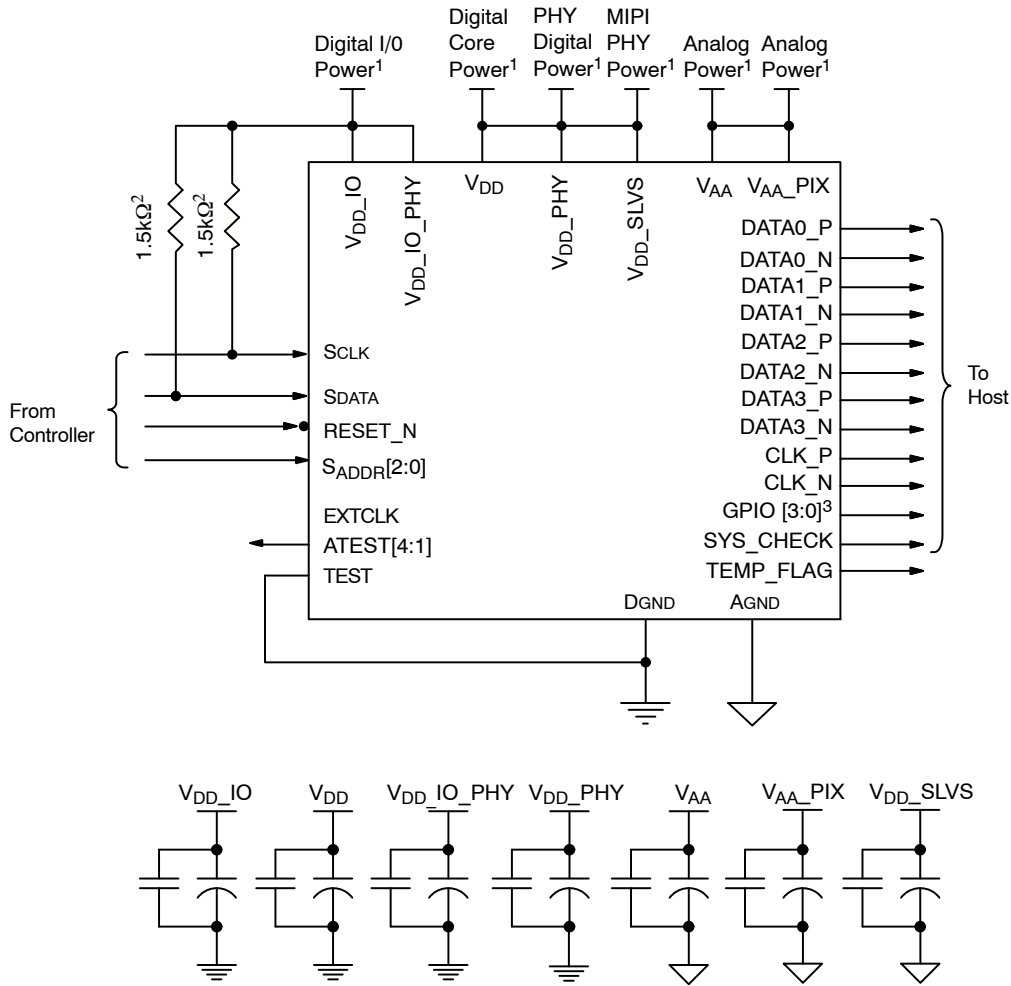

Figure 4. Imaging a Scene

CONFIGURATION AND PINOUT

The figures and tables below show a typical configuration for the AR0221 image sensor and show the package pinout.



1. All power supplies should be adequately decoupled.
2. ON Semiconductor recommends a resistor value of 1.5 kΩ, but a greater value may be used for slower two-wire speed.
3. Different ATEST pins should not be tied together and should be left floating. It is recommended to have the ATEST pins brought out on the PCB and be placed as close as possible to the sensor for debug purpose.
4. ON Semiconductor recommends that 0.1 μF and 10 μF decoupling capacitors for each power supply are mounted as close as possible to the pad. Actual values and results may vary depending on layout and design considerations. Refer to the AR0221 demo headboard schematics for circuit recommendations.
5. ON Semiconductor recommends that analog power planes are placed in a manner such that coupling with the digital power planes is minimized.
6. I/O signals voltage must be configured to match V_{DD_IO} voltage to minimize any leakage currents.
7. I/O signals voltage must be configured to match V_{DD_IO} voltage to minimize any leakage currents.
8. V_{AA} and V_{AA_PIX} are independent on chip but should be tied together externally.
9. Most voltage combinations of V_{DDIO}/V_{DDIO_PHY} are allowed, except V_{DD_IO} = 1V8, V_{DD_IO_PHY} = 2V8.

Figure 5. Typical Configuration: Four-Lane MIPI/HiSpi

Top View
(Ball Down)

Figure 6. 12 x 9 mm 87-Ball iBGA Package

Table 3. 87-BALL iBGA BALL MAP

	1	2	3	4	5	6	7	8	9	10	11
A		D _{GND}	V _{DDIO}	V _{DD}	D _{GND}	D _{GND}	D _{GND}	D _{GND}	V _{DD}	V _{AA}	D _{GND}
B	V _{AA}	A _{GND}	D _{GND}	V _{DDIO}	D _{GND}	D _{GND}	A _{TEST3}	A _{TEST2}	A _{TEST1}	A _{GND}	V _{AA_PIX}
C	DATA3P	DATA3N	V _{DD}	V _{DD_SLVS}	CAP_1UF_PHY	D _{GND}	D _{GND}	A _{TEST4}	A _{GND}	A _{GND}	RESERVED
D	DATA2N	DATA2P	D _{GND}	V _{AA_PHY}	S _{ADDR1}	S _{ADDR2}	D _{GND}	S _{CL}	S _{DA}	D _{GND}	V _{DDIO}
E	CLKN	CLKP	V _{DDIO_PHY}	V _{DD}	GPIO_1	D _{GND}	GPIO_0	D _{GND}	S _{ADDR0}	V _{DDIO}	V _{DD}
F	DATA1N	DATA1P	D _{GND}	V _{DD_PHY}	RESET_N	GPIO_3	D _{GND}	GPIO_2	D _{GND}	V _{DD}	D _{GND}
G	DATA0P	DATA0N	EXTCLK	D _{GND}	SYS_CHECK	D _{GND}	TEMP_FLAG	D _{GND}	TEST	D _{GND}	V _{DDIO}
H	D _{GND}	V _{DDIO}	V _{DD}	D _{GND}	V _{DDIO}	D _{GND}	V _{DD}	D _{GND}	V _{DDIO}	V _{DD}	D _{GND}

Table 4. PIN DESCRIPTIONS, 12 x 9 mm, 87-BALL iBGA

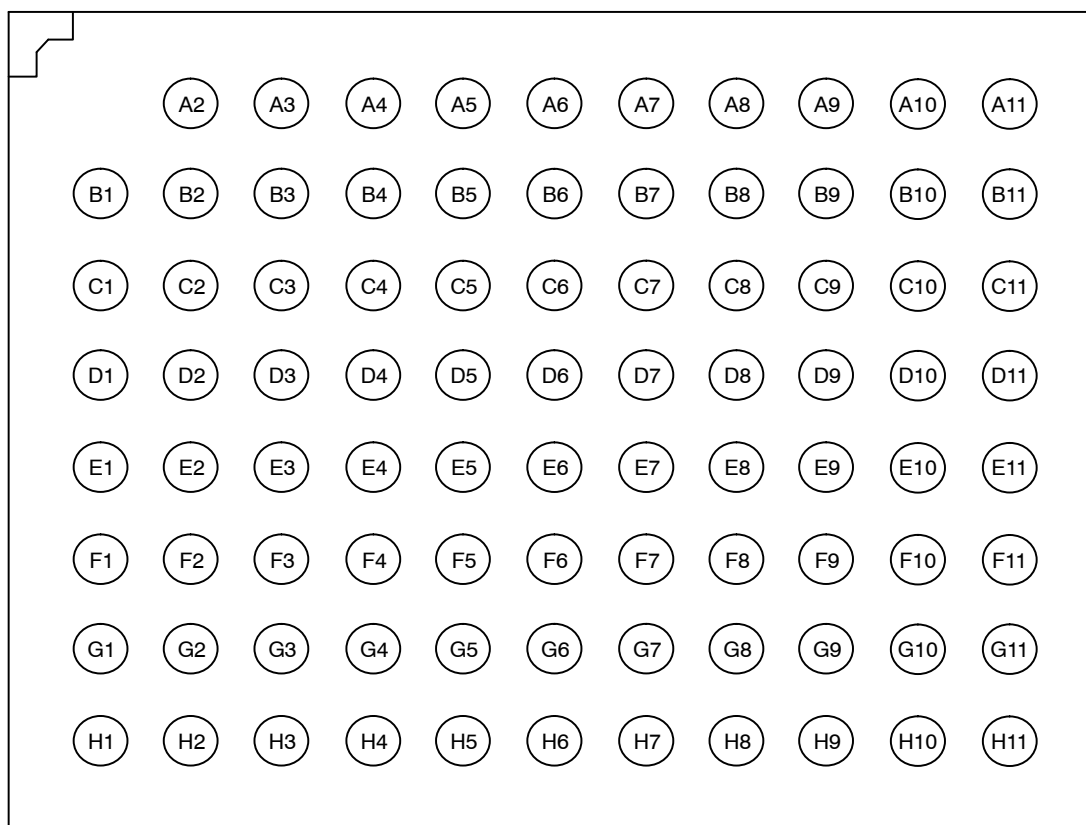
Pin Name	Pin	Type	Description
D _{GND}	A2, A5, A6, A7, A8, A11, B3, B5, B6, C6, C7, D3, D7, D10, E6, E8, F3, F7, F9, F11, G4, G6, G8, G10, H1, H4, H6, H8, H11	Power	Digital ground
V _{DDIO}	A3, B4, D11, E10, G11, H2, H5, H9	Power	Digital I/O power. 1.8 V or 2.8 V nominal

Table 4. PIN DESCRIPTIONS, 12 x 9 mm, 87-BALL iBGA (continued)

Pin Name	Pin	Type	Description
V _{DD}	A4, A9, C3, E4, E11, F10, H3, H7, H10	Power	Core Digital power. 1.2 V nominal
V _{AA}	A10, B1	Power	Analog power. 2.8 V nominal
A _{GND}	B2, B10, C9, C10	Power	Analog ground
A _{TEST3}	B7		Reserved, NC
A _{TEST2}	B8		Reserved, NC
A _{TEST1}	B9		Reserved, NC
V _{AA_PIX}	B11	Power	Analog pixel array power. 2.8 V nominal
DATA3P	C1	Output	Differential MIPI/HiSPi serial data lane 3
DATA3N	C2	Output	Differential MIPI/HiSPi serial data lane 3
V _{DD_SLVS}	C4	Power	Reference voltage for HiSPi serial interface. 1.2 V nominal
CAP_1UF_PHY	C5	Power	external bypass capacitor for MIPI Regulator
A _{TEST4}	C8	I/O	NC in normal operation
RESERVED	C11		Reserved, NC
DATA2N	D1	Output	Differential MIPI/HiSPi serial data lane 2
DATA2P	D2	Output	Differential MIPI/HiSPi serial data lane 2
V _{AA_PHY}	D4	Power	Analog MIPI/HiSPi power. 2.8 V nominal
S _{ADDR1}	D5	Input	Serial interface device ID select
S _{ADDR2}	D6	Input	Serial interface device ID select
SCL	D8	Input	Serial clock for access to control and status registers.
SDA	D9	I/O	Serial data for reads from and writes to control and status registers
CLKN	E1	Output	Differential MIPI/HiSPi serial clock
CLKP	E2	Output	Differential MIPI/HiSPi serial clock
V _{DDIO_PHY}	E3	Power	Power to MIPI and HiSPi PHYs. 1.8 V nominal
GPIO_1	E5	I/O	GPIO pin
GPIO_0	E7	I/O	GPIO pin
S _{ADDR0}	E9	Input	Serial interface device ID select
DATA1N	F1	Output	Differential MIPI/HiSpi serial data lane 1
DATA1P	F2	Output	Differential MIPI/HiSPi serial data lane 1
V _{DD_PHY}	F4	Power	PHY Digital power. 1.2 V nominal
RESET_N	F5	Input	Asynchronous active-low reset. When low, the sensor asynchronously resets
GPIO_3	F6	I/O	GPIO pin
GPIO_2	F8	I/O	GPIO pin
DATA0P	G1	Output	Differential MIPI/HiSPi serial data lane 0
DATA0N	G2	Output	Differential MIPI/HiSPi serial data lane 0
EXTCLK	G3	Input	Master input clock. PLL input clock. 6 ~ 50 MHz
SYS_CHECK	G5	Output	Combined OR of all error flags
TEMP_FLAG	G7	Output	Temperature monitoring flag
TEST	G9	Input	Tied to GND for normal operation

Power-Up Sequence

The available power supplies (VDD_IO, VDD, VDD_SLVS, VAA, VAA_PIX) must have the separation specified below.

10. Turn on VAA and VAA_PIX power supply
11. After 100 μ s, turn on VDD_IO power supply
12. After 100 μ s, turn on VDDIO_PHY(1.8 V) power supply
13. After 100 μ s, turn on VDD power supply
14. After 100 μ s, turn on VDD_SLVS power supply
15. After the last power supply is stable, enable EXTCLK
16. Assert RESET_N for at least 1 ms. The parallel interface will be tri-stated during this time
17. Wait for ~150000 EXTCLKs for internal initialization into soft standby where M3ROM and full OTPM upload would be complete
18. Set streaming mode (mode_select/stream (R0x301A[2]) = 1) and the internal PLL would be enabled (not locked yet)
19. Wait for 1 ms for PLL lock to complete, part will then go into streaming mode

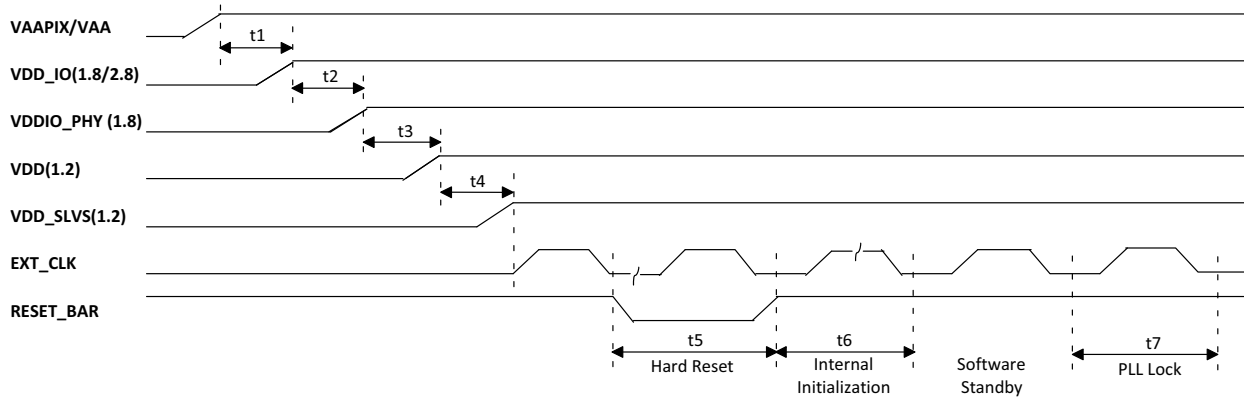

Figure 7. Power-Up Sequence

Table 5. POWER-UP SEQUENCE

SN	Definition	Symbol	Min	Typ	Max
1	VAA/VAA_PIX to VDD_IO (Note 2)	t1	0	100 μ s	-
2	VDD_IO to VDDIO_PHY	t2	0	100 μ s	-
3	VDDIO_PHY to VDD	t3	0	100 μ s	-
4	VDD to VDD_SLVS (Note 3)	t4	0	100 μ s	-
5	Xtal Settle Time (Component Dependent)	tx	-	30 ms	-
6	Hard Reset	t5	1 ms	-	-
7	Internal Initialization	t6	150000 ext clk cycles	-	-
8	PLL Lock Time	t7	1 ms	-	-

2. VDD_IO if 2.8 V can be tied together with VAA/VAA_PIX (t1 becomes '0' in this case).
3. VDD and VDD_SLVS can be tied together (t4 becomes '0' in this case).

Power Down Sequence

Here is the description:

The available power supplies (V_{DD_IO} , V_{DD} , V_{DDIO_PHY} , V_{DD_SLVS} , V_{AA} , V_{AA_PIX}) must have the separation specified below.

1. Disable streaming if output is active by setting standby $R0x301A[2] = 0$

2. The soft standby state is reached after the current row or frame, depending on configuration, has ended
3. Turn off V_{DD_SLVS}
4. Turn off $V_{DD}/V_{DD_IO_PHY}$ *
5. Turn off V_{DD_IO}
6. Turn off V_{AA}/V_{AA_PIX}

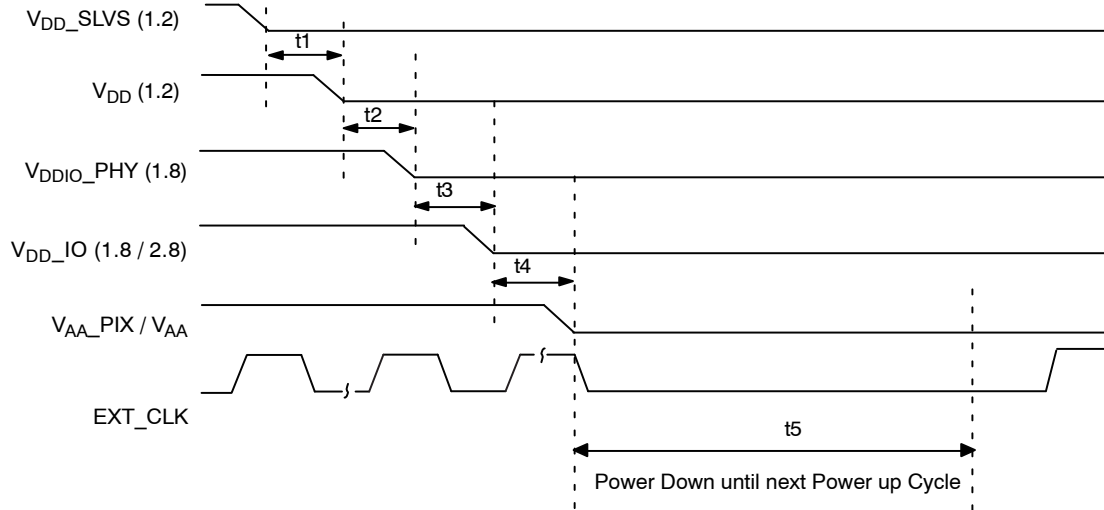

Figure 8. Power Down Sequence

Table 6. POWER-DOWN SEQUENCE

SN	Definition	Symbol	Min	Typ	Max
1	V_{DD_SLVS} to V_{DD} (Note 4)	t1	0	-	-
2	V_{DDIO_PHY} (1.8)	t2	0	-	-
3	V_{DDIO_PHY} to V_{DD_IO}	t3	0	-	-
4	V_{DD_IO} to V_{AA}/V_{AA_PIX} (Note 5)	t4	0	-	-
5	PwrDn until Next Pwrup Time	t5	100 ms	-	-

4. V_{DD} and V_{DD_SLVS} can be tied together
5. V_{DD_IO} If 2.8 V can be tied together with V_{AA}/V_{AA_PIX}

TWO-WIRE SERIAL REGISTER INTERFACE

The two-wire serial interface bus enables read/write access to control and status registers within the AR0221. The interface protocol uses a master/slave model in which a master controls one or more slave devices. The sensor acts as a slave device. The master generates a clock (S_{CLK}) that is an input to the sensor and is used to synchronize transfers. Data is transferred between the master and the slave on a bidirectional signal (S_{DATA}). S_{DATA} is pulled up to V_{DD_IO} off-chip by a 1.5 k Ω resistor. Either the slave or master device can drive S_{DATA} LOW—the interface protocol determines which device is allowed to drive S_{DATA} at any given time.

The protocols described in the two-wire serial interface specification allow the slave device to drive S_{CLK} LOW; the AR0221 uses S_{CLK} as an input only and therefore never drives it LOW.

Protocol

Data transfers on the two-wire serial interface bus are performed by a sequence of low-level protocol elements:

1. A (repeated) start condition
2. A slave address/data direction byte
3. An (a no) acknowledge bit
4. A message byte
5. A stop condition

The bus is idle when both S_{CLK} and S_{DATA} are HIGH. Control of the bus is initiated with a start condition, and the bus is released with a stop condition. Only the master can generate the start and stop conditions.

Start Condition

A start condition is defined as a HIGH-to-LOW transition on S_{DATA} while S_{CLK} is HIGH. At the end of a transfer, the master can generate a start condition without previously generating a stop condition; this is known as a “repeated start” or “restart” condition.

Stop Condition

A stop condition is defined as a LOW-to-HIGH transition on S_{DATA} while S_{CLK} is HIGH.

Data Transfer

Data is transferred serially, 8 bits at a time, with the MSB transmitted first. Each byte of data is followed by an acknowledge bit or a no-acknowledge bit. This data transfer mechanism is used for the slave address/data direction byte and for message bytes.

One data bit is transferred during each S_{CLK} clock period. S_{DATA} can change when S_{CLK} is LOW and must be stable while S_{CLK} is HIGH.

Slave Address/Data Direction Byte

Bits [7:1] of this byte represent the device slave address and bit [0] indicates the data transfer direction. A “0” in bit [0] indicates a WRITE, and a “1” indicates a READ. The default slave addresses used by the AR0221 are 0x20 (write address) and 0x21 (read address) in accordance with the specification. An additional 7 alternate slave address can be selected by enabling and asserting the S_{ADDR} [2:0] inputs.

Table 7. DEVICE SLAVE ADDRESS AND SADDR PINS

SADDR2	SADDR1	SADDR0	Device Address	Register
0	0	0	0x20	R0x3420[7:0]
0	0	1	0x30	R0x3420[15:8]
0	1	0	0x6C	R0x3422[7:0]
0	1	1	0x6E	R0x3422[15:8]
1	0	0	0x40	R0x3424[7:0]
1	0	1	0x50	R0x3424[15:8]
1	1	0	0x60	R0x3426[7:0]
1	1	1	0x70	R0x3426[15:8]

Note:

6. The default device slave address is 0x20, which is implemented by having all SADDR pins grounded.
7. After power up, device slave address in registers, R0x3420, 3422, and 3424 could be configured to other address.
8. The device slave addresses in R0x3426 are hard-coded and could not be changed.

Message Byte

Message bytes are used for sending register addresses and register write data to the slave device and for retrieving register read data.

Acknowledge Bit

Each 8-bit data transfer is followed by an acknowledge bit or a no-acknowledge bit in the S_{CLK} clock period following the data transfer. The transmitter (which is the master when writing, or the slave when reading) releases S_{DATA} . The receiver indicates an acknowledge bit by driving S_{DATA} LOW. As for data transfers, S_{DATA} can change when S_{CLK} is LOW and must be stable while S_{CLK} is HIGH.

No Acknowledge Bit

The no-acknowledge bit is generated when the receiver does not drive S_{DATA} LOW during the S_{CLK} clock period following a data transfer. A no-acknowledge bit is used to terminate a read sequence.

Typical Sequence

A typical READ or WRITE sequence begins by the master generating a start condition on the bus. After the start condition, the master sends the 8-bit slave address/data

direction byte. The last bit indicates whether the request is for a read or a write, where a “0” indicates a write and a “1” indicates a read. If the address matches the address of the slave device, the slave device acknowledges receipt of the address by generating an acknowledge bit on the bus.

If the request was a WRITE, the master then transfers the 16-bit register address to which the WRITE should take place. This transfer takes place as two 8-bit sequences and the slave sends an acknowledge bit after each sequence to indicate that the byte has been received. The master then transfers the data as an 8-bit sequence; the slave sends an acknowledge bit at the end of the sequence. The master stops writing by generating a (re)start or stop condition.

If the request was a READ, the master sends the 8-bit write slave address/data direction byte and 16-bit register address, the same way as with a WRITE request. The master then generates a (re)start condition and the 8-bit read slave address/data direction byte, and clocks out the register data, eight bits at a time. The master generates an acknowledge bit after each 8-bit transfer. The slave’s internal register address is automatically incremented after every 8 bits are transferred. The data transfer is stopped when the master sends a no-acknowledge bit.

Single READ from Random Location

This sequence (Figure 9) starts with a dummy WRITE to the 16-bit address that is to be used for the READ. The master terminates the WRITE by generating a restart condition. The master then sends the 8-bit read slave address/data direction byte and clocks out one byte of

register data. The master terminates the READ by generating a no-acknowledge bit followed by a stop condition. Figure 9 shows how the internal register address maintained by the AR0221 is loaded and incremented as the sequence proceeds.

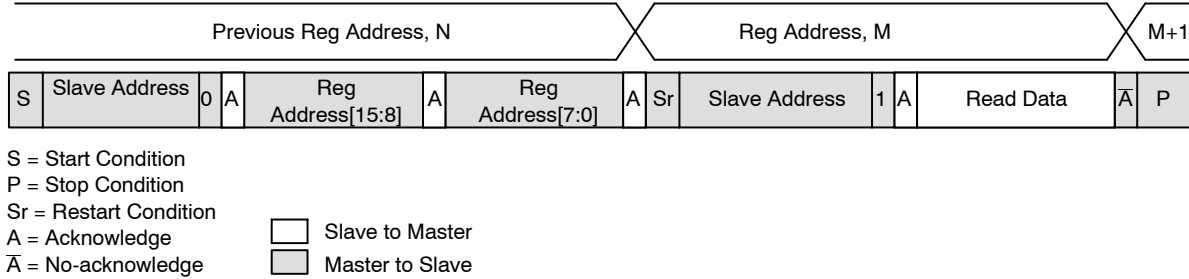

Figure 9. Single READ from Random Location

Single READ from Current Location

This sequence (Figure 10) performs a read using the current value of the AR0221 internal register address.

The master terminates the READ by generating a no-acknowledge bit followed by a stop condition. The figure shows two independent READ sequences.

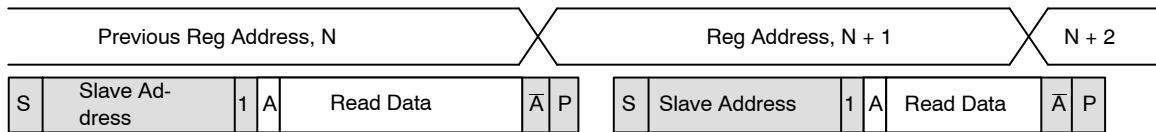

Figure 10. Single READ from Current Location

Sequential READ, Start from Random Location

This sequence (Figure 11) starts in the same way as the single READ from random location (Figure 9). Instead of generating a no-acknowledge bit after the first byte of data

has been transferred, the master generates an acknowledge bit and continues to perform byte READs until “L” bytes have been read.

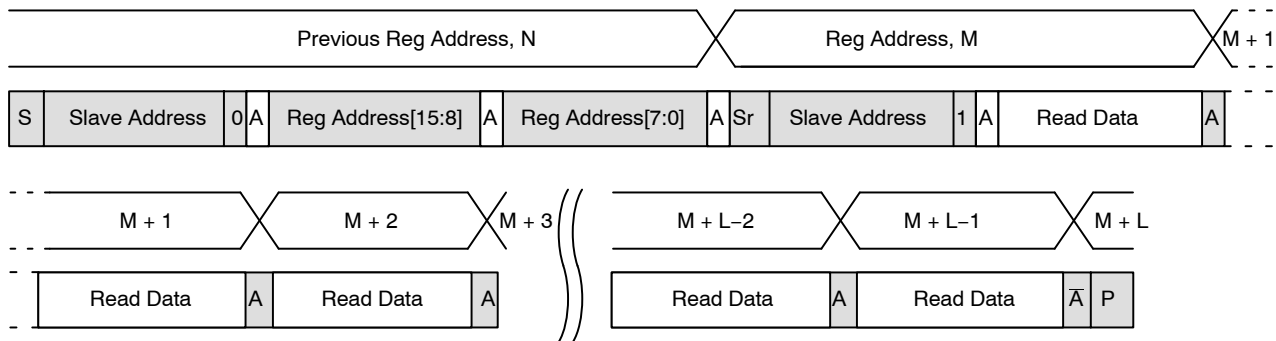

Figure 11. Sequential READ, Start from Random Location

Sequential READ, Start from Current Location

This sequence (Figure 12) starts in the same way as the single READ from current location (Figure 10). Instead of generating a no-acknowledge bit after the first byte of data

has been transferred, the master generates an acknowledge bit and continues to perform byte READs until “L” bytes have been read.

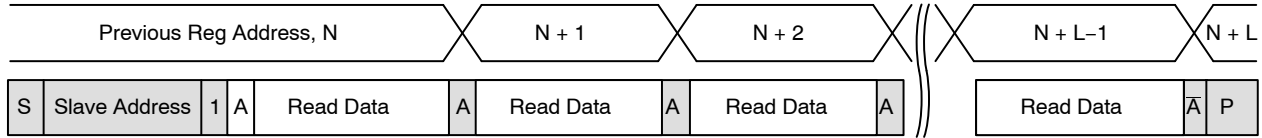

Figure 12. Sequential READ, Start from Current Location

Single Write to Random Location

This sequence (Figure 13) begins with the master generating a start condition. The slave address/data direction by signals a WRITE and is followed by the HIGH

then LOW bytes of the register address that is to be written. The master follows this with the byte of write data. The WRITE is terminated by the master generating a stop condition.

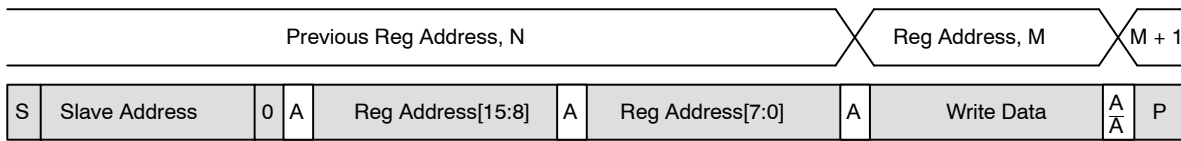

Figure 13. Single WRITE to Random Location

Sequential WRITE, Start at Random Location

This sequence (Figure 14) starts in the same way as the single WRITE to random location (Figure 13). Instead of generating a no-acknowledge bit after the first byte of data

has been transferred, the master generates an acknowledge bit and continues to perform byte WRITES until “L” bytes have been written. The WRITE is terminated by the master generating a stop condition.

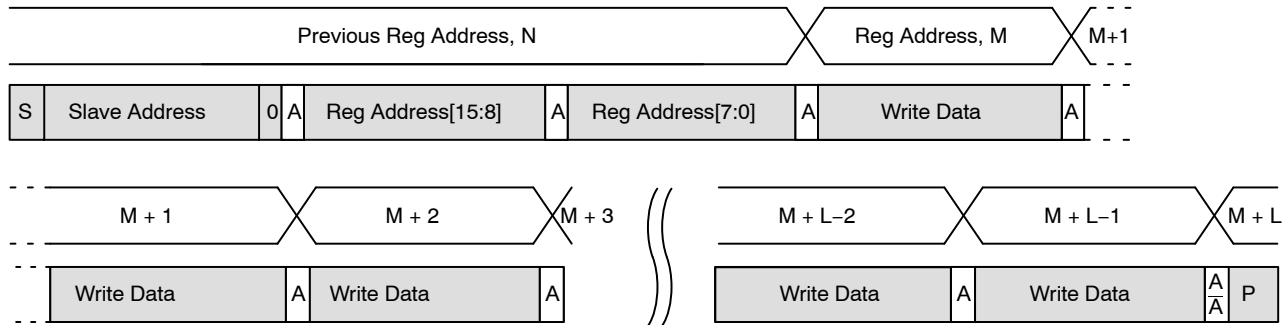

Figure 14. Sequential WRITE, Start at Random Location

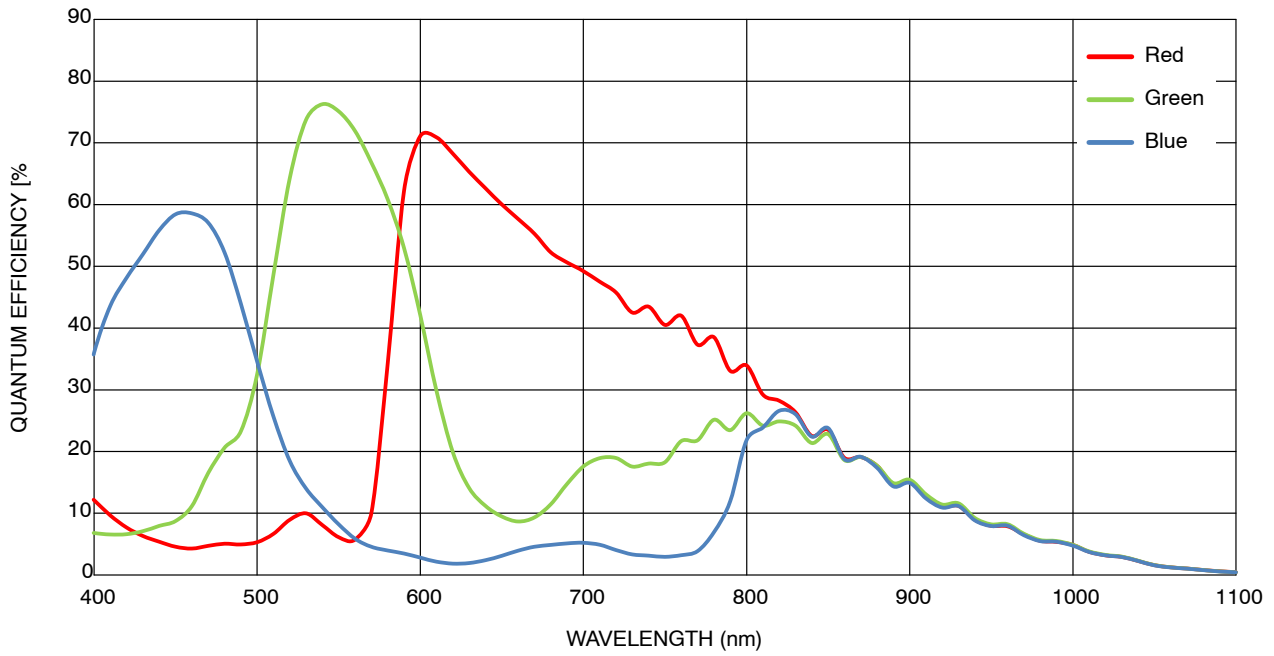

Figure 15. Quantum Efficiency

ELECTRICAL SPECIFICATIONS

Table 8. ABSOLUTE MAXIMUM RATINGS

Symbol	Definition	Condition	Min	Max	Unit
V _{AA_MAX}	Analog Voltage		-0.3	4	V
V _{AA_PIX}	Pixel Supply Voltage		-0.3	4	V
V _{DD_IO_MAX}	I/O Digital Voltage		-0.3	4	V
V _{DD_IO_PHY}	Power to MIPI		-0.3	2.4	V
V _{DD_MAX}	Core Digital Voltage		-0.3	2.4	V
V _{DD_SLVS_MAX}	HiSpi I/O Digital Voltage		-0.3	2.4	V
t _{ST}	Storage Temperature		-40	125	°C

Stresses exceeding those listed in the Maximum Ratings table may damage the device. If any of these limits are exceeded, device functionality should not be assumed, damage may occur and reliability may be affected.

Table 9. OPERATING CONDITIONS

Symbol	Definition	Min	Typ	Max	Unit
V _{AA}	Analog Power	2.6	2.8	3	V
V _{AA_PIX}	Analog Pixel Voltage	2.6	2.8	3	
V _{AA_PHY}	Power to MIPI	2.6	2.8	3	
V _{DDIO}	IO Power	1.7/2.6	1.8/2.8	1.9/3	
V _{DDIO_PHY}	Power to MIPI	1.7	1.8	1.9	
V _{DD}	Digital Power	1.14	1.2	1.26	
V _{DD_PHY}	Power to MIPI	1.14	1.2	1.26	
V _{DD_SLVS}	SLVS PHY Power	1.14	1.2	1.26	

Table 10. DC ELECTRICAL CHARACTERISTICS

Symbol	Definition	Condition	Min	Typ	Max	Unit
V _{IH}	Input HIGH Voltage		V _{DD_IO} x 0.7	-	-	V
V _{IL}	Input LOW Voltage		-	-	V _{DD_IO} x 0.3	V
I _{IN}	Input leakage Current	No Pull-up Resistor; V _{IN} = V _{DD_IO} or DGND	-	-	20	μA
V _{OH}	Output HIGH Voltage		V _{DD_IO} - 0.3	-	-	V
V _{OL}	Output LOW Voltage		-	-	0.4	V
I _{OH}	Output HIGH Current	At Specified V _{OH}	10	-	30	mA
I _{OL}	Output LOW Current	At Specified V _{OL}	10	-	30	mA

Table 11. OPERATING CURRENT CONSUMPTION

$T_J = 55^\circ\text{C}$ ($\pm 35^\circ\text{C}$), $V_{AA} = V_{AA_PIX} = 2.8\text{ V}$, $V_{DD} = V_{DD_PHY} = V_{DD_SLVS} = 1.2\text{ V}$, $V_{DD_IO} = V_{DDIO_PHY} = 2.8\text{ V}$ – ANALOG GAIN 1X
LCG

Conditions	Symbol	Min	Typ	Max	Unit
1080p30 Linear 74.7 MHz HiSPi SLVS	IAA	–	36.14	90	mA
	IAA_PIX		6.54	30	
	IDDIO	–	0.18	10	
	IDDIO_PHY	–	6.29	30	
	IDD		109.34	200	
	IDD_PHY		10.28	30	
	IDD_SLVS	–	11.15	25	
	Power	–	295	754	mW
1080p60 Linear 74.7 MHz HiSPi SLVS	IAA	–	36.15	90	mA
	IAA_PIX		6.55	30	
	IDDIO	–	0.17	10	
	IDDIO_PHY	–	7.39	30	
	IDD	–	110.95	200	
	IDD_PHY		10.27	30	
	IDD_SLVS		11.37	25	
	Power	–	300	754	mW
1080p30 Linear 74.7 MHz MIPI	IAA	–	36.1	90	mA
	IAA_PIX		6.54	30	
	IDDIO	–	0.17	10	
	IDDIO_PHY	–	5.29	30	
	IDD	–	101.19	200	
	IDD_PHY		8.08	30	
	IDD_SLVS		5.09	25	
	Power	–	272	754	mW
1080p60 Linear 74.7 MHz MIPI	IAA	–	36.15	90	mA
	IAA_PIX		6.54	30	
	IDDIO	–	0.17	10	
	IDDIO_PHY	–	6.61	30	
	IDD	–	105.14	200	
	IDD_PHY		8.95	30	
	IDD_SLVS		7.36	25	
	Power	–	284	754	mW
1080p30 Line-Interleaved 72 MHz HiSPi SLVS	IAA	–	49.98	90	mA
	IAA_PIX		9.73	30	
	IDDIO	–	0.18	10	
	IDDIO_PHY	–	9.01	30	
	IDD	–	124.81	300	
	IDD_PHY		10.49	30	
	IDD_SLVS		11.68	25	
	Power	–	369	754	mW

Table 11. OPERATING CURRENT CONSUMPTION (continued)

$T_J = 55^\circ\text{C}$ ($\pm 35^\circ\text{C}$), $V_{AA} = V_{AA_PIX} = 2.8\text{ V}$, $V_{DD} = V_{DD_PHY} = V_{DD_SLVS} = 1.2\text{ V}$, $V_{DD_IO} = V_{DDIO_PHY} = 2.8\text{ V} - \text{ANALOG GAIN } 1X$
LCG

Conditions	Symbol	Min	Typ	Max	Unit
1080p30 Line-Interleaved 72 MHz MIPI	IAA	-	49.96	90	mA
	IAA_PIX		9.72	30	
	IDDIO	-	0.17	10	
	IDDIO_PHY	-	8.58	30	
	IDD	-	124	200	
	IDD_PHY		10.19	30	
	IDD_SLVS		10.5	25	
Power	-	365	754	mW	

Table 12. I/O TIMING CHARACTERISTICS (2.8 V V_{DD_IO}) (Note 9)

Symbol	Definition	Condition	$V_{DD_IO} = 2.8\text{ V}$			Unit
			Min	Typ	Max	
f_{EXTCLK}	Input clock frequency	PLL Enabled	6	-	50	MHz
t_{EXTCLK}	Input clock period	PLL Enabled	20	-	166	ns
t_R	Input clock rise time		-	3	-	ns
t_F	Input clock fall time		-	3	-	ns
t_{JITTER}	Input clock jitter		-	-	100	ps

9. All values are taken at the 50% transition point. The loading used is 20 pF.

Table 13. I/O TIMING CHARACTERISTICS (1.8 V V_{DD_IO}) (Note 10)

Symbol	Definition	Condition	$V_{DD_IO} = 1.8\text{ V}$			Unit
			Min	Typ	Max	
f_{EXTCLK}	Input clock frequency	PLL Enabled	6	-	50	MHz
t_{EXTCLK}	Input clock period	PLL Enabled	20	-	166	ns
t_R	Input clock rise time		-	3	-	ns
t_F	Input clock fall time		-	3	-	ns
t_{JITTER}	Input clock jitter		-	-	100	ps

10. All values are taken at the 50% transition point. The loading used is 20 pF.

Two-Wire Serial Register Interface

The electrical characteristics of the two-wire serial register interface (S_{CLK} , S_{DATA}) are shown in Figure 16 and Table 14.

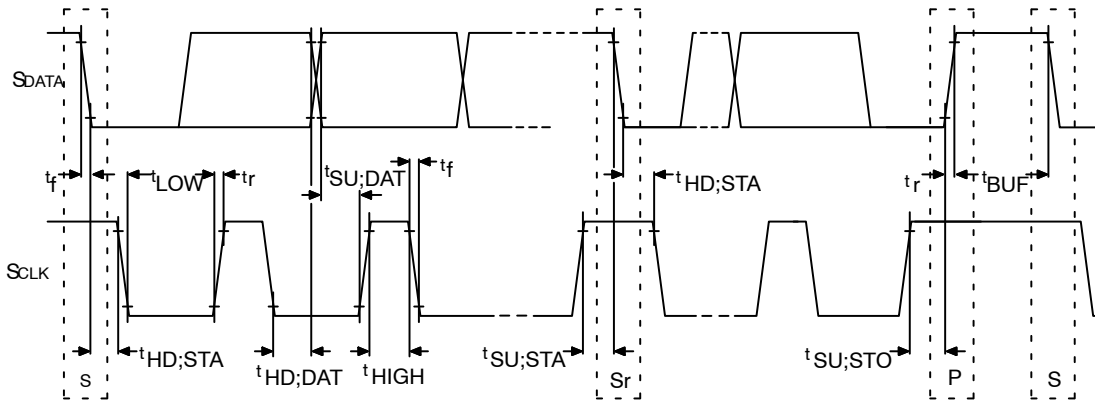

Note: Read sequence: For an 8-bit READ, read waveforms start after WRITE command and register address are issued.

Figure 16. Two-Wire Serial Bus Timing Parameters

Table 14. TWO-WIRE SERIAL BUS CHARACTERISTICS

$f_{EXTCLK} = 27 \text{ MHz}$; $V_{DD} = V_{DD_PHY} = V_{DD_SLVS} = 1.2 \text{ V}$; $V_{DD_IO} = V_{DD_IO_PHY} = V_{AA} = V_{AA_PIX} = 2.8 \text{ V}$; $T_A = 25^\circ\text{C}$

Parameter	Symbol	Standard Mode		Fast Mode		Fast Mode Plus		Unit
		Min	Max	Min	Max	Min	Max	
M_SCLK Clock Frequency	f_{SCL}	0	100	0	400	0	1000	kHz
SCLK High		8 * EXTCLK + SCLK rise time		8 * EXTCLK + SCLK rise time		8 * EXTCLK + SCLK rise time		μs
SCLK Low	f_{SCL}	6 * EXTCLK + SCLK rise time		6 * EXTCLK + SCLK rise time		6 * EXTCLK + SCLK rise time		μs
Hold time (repeated) START condition. After this period, the first clock pulse is generated	$t_{HD;STA}$	4	–	0.6	–	0.26	–	μs
LOW period of the SCLK clock	t_{LOW}	4.7	–	1.2	–	0.5	–	μs
HIGH period of the SCLK clock	t_{HIGH}	4	–	0.6	–	0.26	–	μs
Set-up time for a repeated START condition	$t_{SU;STA}$	4.7	–	0.6	–	0.26	–	μs
Data hold time	$t_{HD;DAT}$	0 (Note 14)	3.45 (Note 15)	0 (Note 14)	0.9 (Note 15)	0	–	μs
Data set-up time	$t_{SU;DAT}$	250	–	100 (Note 16)	–	50	–	ns
Rise time of both SDATA and SCLK signals	t_r	–	1000	$20 + 0.1C_b$ (Note 17)	300	–	120	ns
Fall time of both SDATA and SCLK signals	t_f	–	300	$20 + 0.1C_b$ (Note 17)	300	–	120	ns
Set-up time for STOP condition	$t_{SU;STO}$	4	–	0.6	–	0.26	–	μs
Bus free time between a STOP and START condition	t_{BUF}	4.7	–	1.3	–	0.5	–	μs
Capacitive load for each bus line	C_b	–	400	–	400	–	550	pF
Serial interface input pin capacitance	C_{IN_SI}	–	3.3	–	3.3	–	3.3	pF

Table 14. TWO-WIRE SERIAL BUS CHARACTERISTICS (continued)

$f_{EXTCLK} = 27$ MHz; $V_{DD} = V_{DD_PHY} = V_{DD_SLVS} = 1.2$ V; $V_{DD_IO} = V_{DD_IO_PHY} = V_{AA} = V_{AA_PIX} = 2.8$ V; $T_A = 25^\circ\text{C}$

Parameter	Symbol	Standard Mode		Fast Mode		Fast Mode Plus		Unit
		Min	Max	Min	Max	Min	Max	
SDATA max load capacitance	C_{LOAD_SD}	–	30	–	30	–	30	pF
SDATA pull-up resistor	R_{SD}	1.5	4.7	1.5	4.7	1.5	4.7	k Ω

11. This table is based on I2C-bus specification.

12. Two-wire control is I2C-compatible.

13. All values referred to $V_{IHmin} = 0.7$ VDD and $V_{ILmax} = 0.3$ VDD levels. Sensor EXCLK = 27 MHz.

14. A device must internally provide a hold time of at least 300 ns for the SDATA signal to bridge the undefined region of the falling edge of SCLK.

15. The maximum tHD;DAT has only to be met if the device does not stretch the LOW period (tLOW) of the SCLK signal.

16. A Fast-mode I2C-bus device can be used in a Standard-mode I2C-bus system, but the requirement tSU;DAT 250 ns must then be met.

This will automatically be the case if the device does not stretch the LOW period of the SCLK signal. If such a device does stretch the LOW period of the SCLK signal, it must output the next data bit to the SDATA line $t_{rmax} + t_{SU;DAT} = 1000 + 250 = 1250$ ns (according to the Standard-mode I2C-bus specification) before the SCLK line is released.

17. Cb = total capacitance of one bus line in pF.

MIPI Electrical Specifications

The ON Semiconductor AR0221 sensor supports four lanes of MIPI data. Compliant to MIPI standards:

- MIPI Alliance Standard for CSI-2 version 1.0
- MIPI Alliance Standard for D-PHY version 1.1

MIPI AC AND DC ELECTRICAL CHARACTERISTICS**Table 15. MIPI HIGH-SPEED TRANSMITTER DC CHARACTERISTICS**

Symbol	Parameter	Min	Typ	Max	Unit
V_{OD}	HS transmit differential voltage	140	–	270	mV
V_{CMTX}	HS transmit static common mode voltage	150	–	250	mV
ΔV_{OD}	V_{OD} mismatch when output is Differential-1 or Differential-0	–	–	14	mV
$\Delta V_{CMTX(1,0)}$	V_{CMTX} mismatch when output is Differential-1 or Differential-0	–	–	5	mV
V_{OHHS}	HS output HIGH voltage	–	–	360	mV
Z_{OS}	Single-ended output impedance	40	–	62.5	Ω
ΔZ_{OS}	Single-ended output impedance mismatch	–	–	10	%

Table 16. MIPI HIGH-SPEED TRANSMITTER AC CHARACTERISTICS

Symbol	Parameter	Min	Typ	Max	Unit
	Data bit rate	–	–	600	Mb/s
Data Lane t_{rise}	20–80% rise time	100	–	500	ps
Data Lane t_{fall}	20–80% fall time	100	–	500	ps
Clock Lane t_{rise}	20–80% rise time	150	–	500	ps
Clock Lane t_{fall}	20–80% fall time	150	–	500	ps

Table 17. MIPI LOW-POWER TRANSMITTER DC CHARACTERISTICS

Symbol	Parameter	Min	Typ	Max	Unit
V_{OL}	Thevenin output low level	–	–	50	mV
V_{OH}	Thevenin output high level	1.1	1.15	1.3	V
Z_{OLP}	Output impedance of LP transmitter	110	–	–	

Table 18. MIPI LOW-POWER TRANSMITTER AC CHARACTERISTICS

Symbol	Parameter	Min	Typ	Max	Unit
t_{rise}	15–85% rise time	–	–	25	ns
t_{fall}	15–85% fall time	–	–	25	ns
Slew	Slew rate (C_{LOAD} 5–20 pF)	–	–	250	mV/ns
Slew	Slew rate (C_{LOAD} 20–70 pF)	–	–	150	mV/ns

IBGA87 12x9
CASE 503BR
ISSUE A

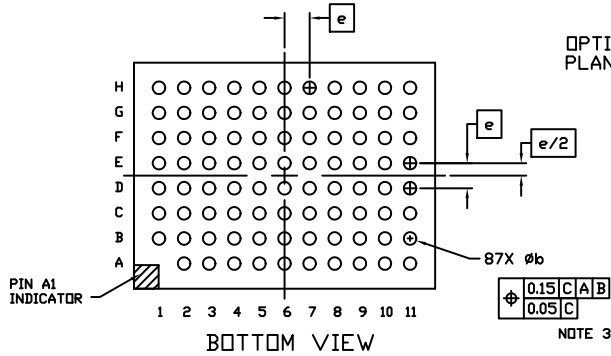
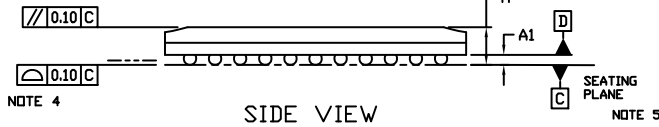
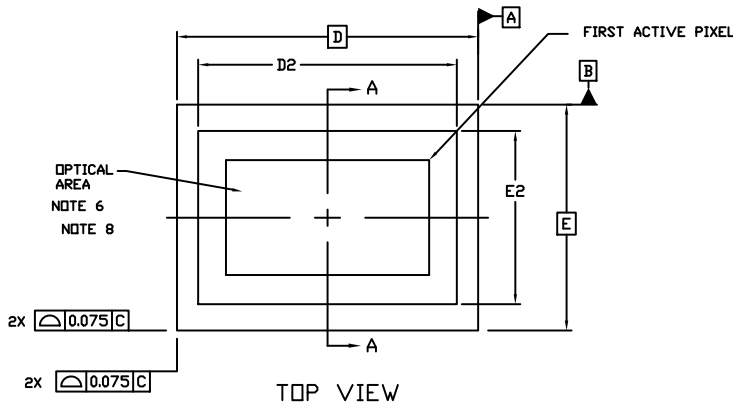

NOTES:

1. DIMENSIONING AND TOLERANCING PER ASME Y14.5M, 1994.
2. CONTROLLING DIMENSION: MILLIMETERS
3. DIMENSION b IS MEASURED AT THE MAXIMUM SOLDER BALL DIAMETER PARALLEL TO DATUM C.
4. COPLANARITY APPLIES TO THE SPHERICAL CROWNS OF THE SOLDER BALLS.
5. DATUM C, THE SEATING PLANE, IS DEFINED BY THE SPHERICAL CROWNS OF THE SOLDER BALLS.
6. MAXIMUM ROTATION OF THE OPTICAL AREA RELATIVE TO D AND E WILL BE 0.5°. OPTICAL AREA IS DEFINED BY THE ACTIVE PIXEL ARRAY. REFER TO THE DEVICE DATASHEET FOR TOTAL ARRAY AND FIRST PIXEL DEFINITIONS.
7. PARALLELISM APPLIES ONLY TO THE OPTICAL AREA.
8. OPTICAL CENTER OFFSET WITH RESPECT TO THE PACKAGE CENTER IS X=-220.41 MICRONS, Y=-147.01 MICRONS ±75 MICRONS.

NOTE 7

DIM	MILLIMETERS	
	MIN.	MAX.
A	---	1.65
A1	0.35	0.45
A3	0.425	0.525
A4	0.575	0.675
b	0.45	0.55
D	12.00 BSC	
D2	10.20	10.40
E	9.00 BSC	
E2	6.80	7.00
e	1.00 BSC	

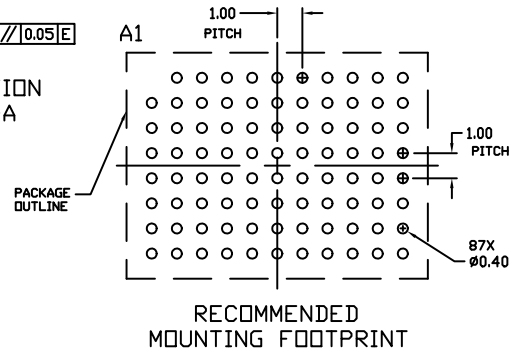
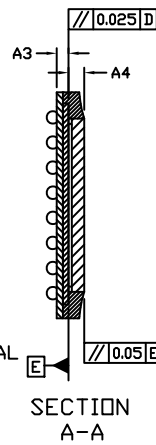

DR-Pix is a trademark of Semiconductor Components Industries, LLC (SCILLC) or its subsidiaries in the United States and/or other countries.

ON Semiconductor and are trademarks of Semiconductor Components Industries, LLC dba ON Semiconductor or its subsidiaries in the United States and/or other countries. ON Semiconductor owns the rights to a number of patents, trademarks, copyrights, trade secrets, and other intellectual property. A listing of ON Semiconductor's product/patent coverage may be accessed at www.onsemi.com/site/pdf/Patent-Marking.pdf. ON Semiconductor reserves the right to make changes without further notice to any products herein. ON Semiconductor makes no warranty, representation or guarantee regarding the suitability of its products for any particular purpose, nor does ON Semiconductor assume any liability arising out of the application or use of any product or circuit, and specifically disclaims any and all liability, including without limitation special, consequential or incidental damages. Buyer is responsible for its products and applications using ON Semiconductor products, including compliance with all laws, regulations and safety requirements or standards, regardless of any support or applications information provided by ON Semiconductor. "Typical" parameters which may be provided in ON Semiconductor data sheets and/or specifications can and do vary in different applications and actual performance may vary over time. All operating parameters, including "Typicals" must be validated for each customer application by customer's technical experts. ON Semiconductor does not convey any license under its patent rights nor the rights of others. ON Semiconductor products are not designed, intended, or authorized for use as a critical component in life support systems or any FDA Class 3 medical devices or medical devices with a same or similar classification in a foreign jurisdiction or any devices intended for implantation in the human body. Should Buyer purchase or use ON Semiconductor products for any such unintended or unauthorized application, Buyer shall indemnify and hold ON Semiconductor and its officers, employees, subsidiaries, affiliates, and distributors harmless against all claims, costs, damages, and expenses, and reasonable attorney fees arising out of, directly or indirectly, any claim of personal injury or death associated with such unintended or unauthorized use, even if such claim alleges that ON Semiconductor was negligent regarding the design or manufacture of the part. ON Semiconductor is an Equal Opportunity/Affirmative Action Employer. This literature is subject to all applicable copyright laws and is not for resale in any manner.

PUBLICATION ORDERING INFORMATION Shenzhen Sunnywale Inc, www.sunnywale.com, awin@sunnywale.com, Wechat: 9308762

LITERATURE FULFILLMENT:
Literature Distribution Center for ON Semiconductor
19521 E. 32nd Pkwy, Aurora, Colorado 80011 USA
Phone: 303-675-2175 or 800-344-3860 Toll Free USA/Canada
Fax: 303-675-2176 or 800-344-3867 Toll Free USA/Canada
Email: orderlit@onsemi.com

N. American Technical Support: 800-282-9855 Toll Free
USA/Canada
Europe, Middle East and Africa Technical Support:
Phone: 421 33 790 2910

ON Semiconductor Website: www.onsemi.com
Order Literature: <http://www.onsemi.com/orderlit>
For additional information, please contact your local Sales Representative