

# WL18xxMOD WiLink™ 8 单频段 Combo 模块 – Wi-Fi®, Bluetooth®, 和 Bluetooth 低功耗 (BLE)

## 1 器件概述

### 1.1 特性

- 常规说明
  - 集成了射频 (RF)、功率放大器 (PA)、时钟、RF 开关、滤波器、无源器件和电源管理单元
  - 可利用 TI 模块配套资料和参考设计实现快速硬件设计
  - 工作温度:  $-20^{\circ}\text{C}$  至  $70^{\circ}\text{C}$
  - 小封装尺寸:  $13.3\text{mm} \times 13.4\text{mm} \times 2\text{mm}$
  - 100 引脚 MOC 封装
  - 经 FCC, IC, ETSI/CE 和 TELEC 认证的芯片天线
- **Wi-Fi**
  - 支持 IEEE 标准 802.11a、802.11b、802.11g 和 802.11n 的 WLAN 基带处理器和 RF 收发器
  - 2.4GHz 20MHz 和 40MHz 单输入单输出 (SISO) 以及 2.4GHz 20MHz 2 x 2 多输入多输出 (MIMO), 针对高数据吞吐量: 80Mbps (TCP), 100Mbps (UDP)
  - 2.4GHz 最大比合并 (MRC), 支持扩展范围
  - 完全校准: 无需生产校准
  - 4 位 SDIO 主机接口支持
  - Wi-Fi 直接并发运行 (多通道、多用途)
- **Bluetooth 和 BLE (仅适用于 WL183xMOD)**
  - 支持 *Bluetooth* 4.1 和 CSA2
  - 主机控制器接口 (HCI) 传输, 用于通过通用异步收发器 (UART) 进行的 *Bluetooth* 传输
  - 支持子带 (SBC) 编码 + 高级音频传输协议 (A2DP) 的专用音频处理器
  - 双模 *Bluetooth* 和 BLE
  - Bluetopia + LE 认证堆栈 (由 TI 提供)
- **主要优势**
  - 减少设计开销
  - 通过在两极 (STA 和 AP) 上同时配置 WiLink 8, 可将差别化的使用案例直接连接至不同 RF 通道 (Wi-Fi 网络) 上的其它 Wi-Fi 器件
  - 用于高性能音频和视频流参考应用的一流 Wi-Fi, 覆盖范围高达单根天线的 1.4 倍
  - 提供多种配置方法, 可一步将室内设备连接至 Wi-Fi
  - 连接空闲时最低 Wi-Fi 功耗 ( $< 800\mu\text{A}$ )
  - WLAN 滤波器上只将系统唤醒的可配置唤醒
  - Wi-Fi-Bluetooth 单天线共存

### 1.2 应用范围

- 物联网
- 多媒体
- 家用电子产品
- 家用电器和大型家电
- 工业和家庭自动化
- 智能网关和仪表计量
- 视频会议
- 视频摄像机和安防器材



### 1.3 说明

TI 经认证的 WiLink 8 模块采用功率优化设计，可提供高数据吞吐量和扩展范围，并且支持 Wi-Fi 和 Bluetooth 共存（只适用于 WL1835MOD）。WL18x5MOD 器件是一套 2.4GHz 模块双天线解决方案。该器件经 FCC、IC、ETSI/CE 和 TELEC 认证，适用于接入点 (AP) 和客户端。TI 为 Linux®、Android™、WinCE 和 RTOS 等高级操作系统提供了驱动程序。

器件信息

订货编号	封装	封装尺寸
WL1801MOD	MOC (100)	13.3mm × 13.4mm × 2mm
WL1805MOD	MOC (100)	13.3mm × 13.4mm × 2mm
WL1831MOD	MOC (100)	13.3mm × 13.4mm × 2mm
WL1835MOD	MOC (100)	13.3mm × 13.4mm × 2mm

### 1.4 功能方框图

图 1-1 显示了 WL1835 变型的功能方框图。



图 1-1. WL1835 功能方框图

## 内容

<b>1</b>	<b>器件概述</b> .....	<b>1</b>	5.12	Timing and Switching Characteristics .....	<b>18</b>
1.1	特性 .....	<b>1</b>	<b>6</b>	<b>Detailed Description</b> .....	<b>26</b>
1.2	应用范围 .....	<b>1</b>	6.1	WLAN .....	<b>27</b>
1.3	说明 .....	<b>2</b>	6.2	<i>Bluetooth</i> .....	<b>27</b>
1.4	功能方框图 .....	<b>2</b>	6.3	BLE .....	<b>28</b>
<b>2</b>	<b>修订历史记录</b> .....	<b>3</b>	6.4	WiLink 8 Module Markings .....	<b>28</b>
<b>3</b>	<b>Device Comparison</b> .....	<b>4</b>	6.5	Test Grades .....	<b>29</b>
<b>4</b>	<b>Terminal Configuration and Functions</b> .....	<b>5</b>	<b>7</b>	<b>Applications and Implementation</b> .....	<b>30</b>
4.1	Pin Description .....	<b>7</b>	7.1	Application Information .....	<b>30</b>
<b>5</b>	<b>Specifications</b> .....	<b>10</b>	<b>8</b>	<b>Device and Documentation Support</b> .....	<b>35</b>
5.1	Absolute Maximum Ratings .....	<b>10</b>	8.1	Device Support .....	<b>35</b>
5.2	Handling Ratings .....	<b>10</b>	8.2	Related Links .....	<b>35</b>
5.3	Power-On Hours (POH) .....	<b>10</b>	8.3	社区资源 .....	<b>35</b>
5.4	Recommended Operating Conditions .....	<b>10</b>	8.4	商标 .....	<b>35</b>
5.5	External Digital Slow Clock Requirements .....	<b>11</b>	8.5	静电放电警告 .....	<b>36</b>
5.6	Thermal Characteristics .....	<b>11</b>	8.6	术语表 .....	<b>36</b>
5.7	WLAN Performance .....	<b>12</b>	<b>9</b>	<b>Mechanical Packaging and Orderable Information</b> .....	<b>37</b>
5.8	<i>Bluetooth</i> Performance .....	<b>14</b>	9.1	TI Module Mechanical Outline .....	<b>37</b>
5.9	<i>Bluetooth</i> LE Performance .....	<b>16</b>	9.2	Packaging Information .....	<b>38</b>
5.10	<i>Bluetooth</i> -BLE Dynamic Currents .....	<b>17</b>			
5.11	<i>Bluetooth</i> LE Currents .....	<b>18</b>			

## 2 修订历史记录

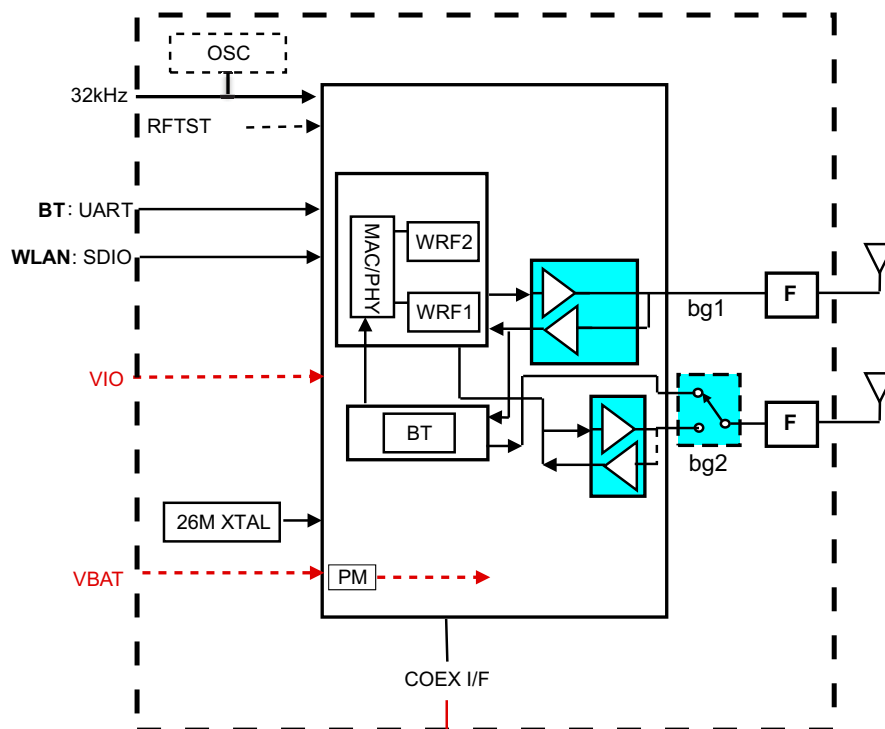
Changes from Revision I (August 2014) to Revision J		Page
• Changed <a href="#">节 1.1</a> , <i>特性</i> .....		<b>1</b>
• Changed <a href="#">节 1.2</a> , <i>应用</i> .....		<b>1</b>
• Changed organization of <a href="#">节 9</a> , <i>Mechanical Packaging and Orderable Information</i> .....		<b>37</b>

### 3 Device Comparison

The TI WiLink 8 module offers four footprint-compatible 2.4-GHz variants providing stand-alone and *Bluetooth* combo connectivity. [Table 3-1](#) compares the features of the module variants.

**Table 3-1. TI WiLink 8 Module Variants**

DEVICE	WLAN 2.4-GHZ SISO <sup>(1)</sup>	WLAN 2.4-GHZ MIMO <sup>(1)</sup>	WLAN 2.4-GHZ MRC <sup>(1)</sup>	BLUETOOTH
WL1835MOD	√	√	√	√
WL1831MOD	√			√
WL1805MOD	√	√	√	
WL1801MOD	√			

(1) SISO: single input, single output; MIMO: multiple input, multiple output; MRC: maximum ratio combining.

## 4 Terminal Configuration and Functions

Figure 4-1 shows the pin assignments for the 100-pin MOC package.

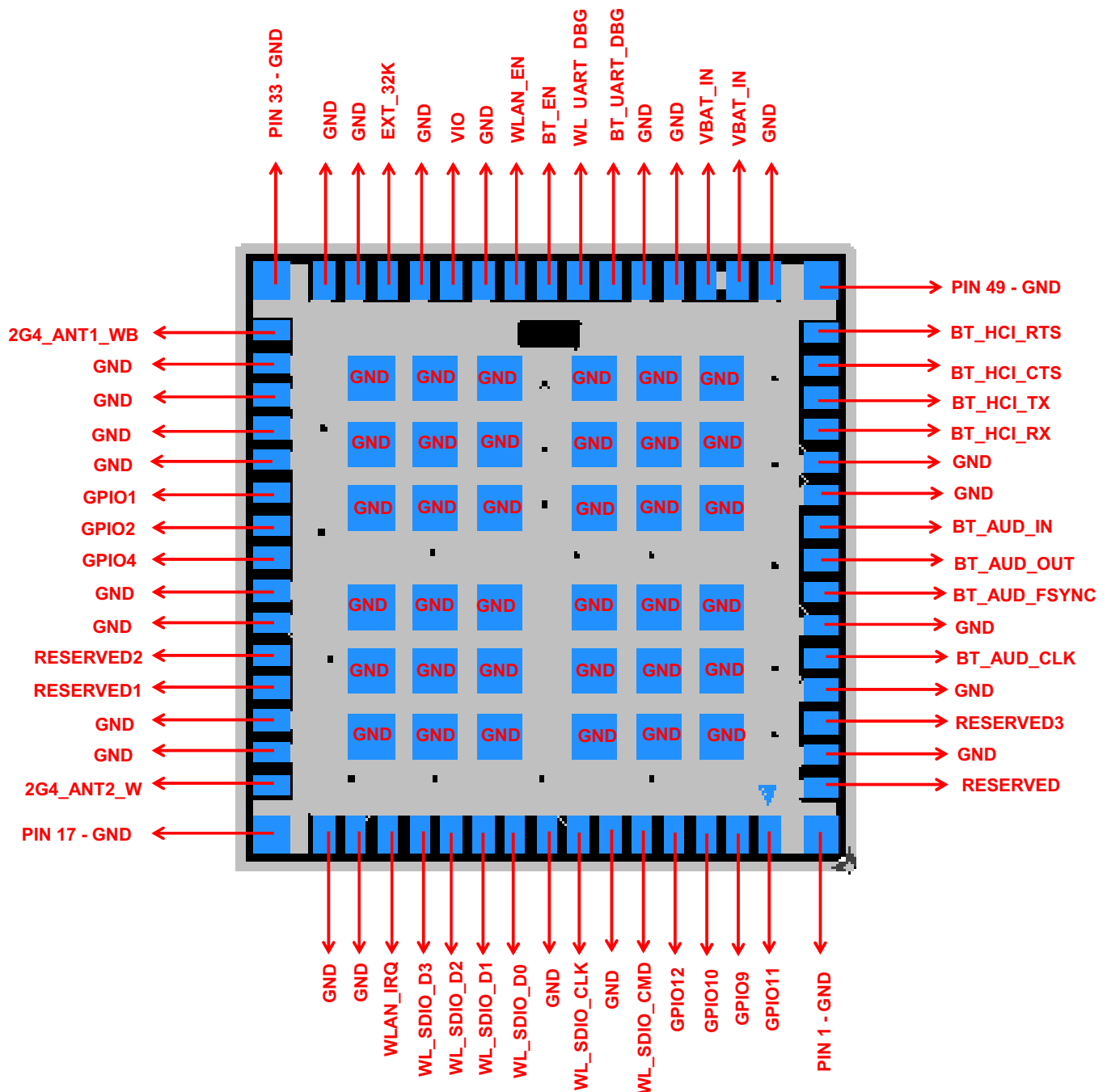

Figure 4-1. 100-Pin MOC Package (Bottom View)

Figure 4-2 shows the outline of the 100-pin MOC package.

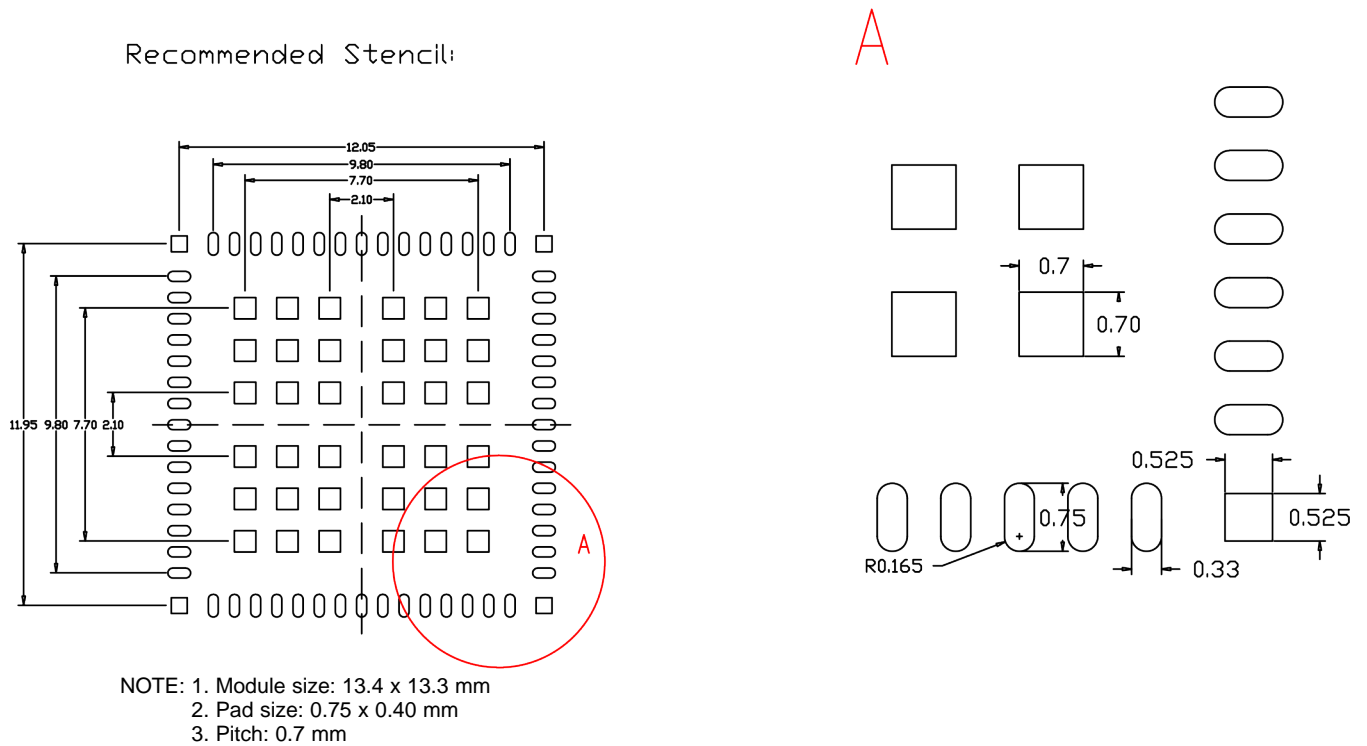

Figure 4-2. Outline of 100-Pin MOC Package

Figure 4-3 shows the outline of the recommended PCB pattern for the 100-pin MOC package.

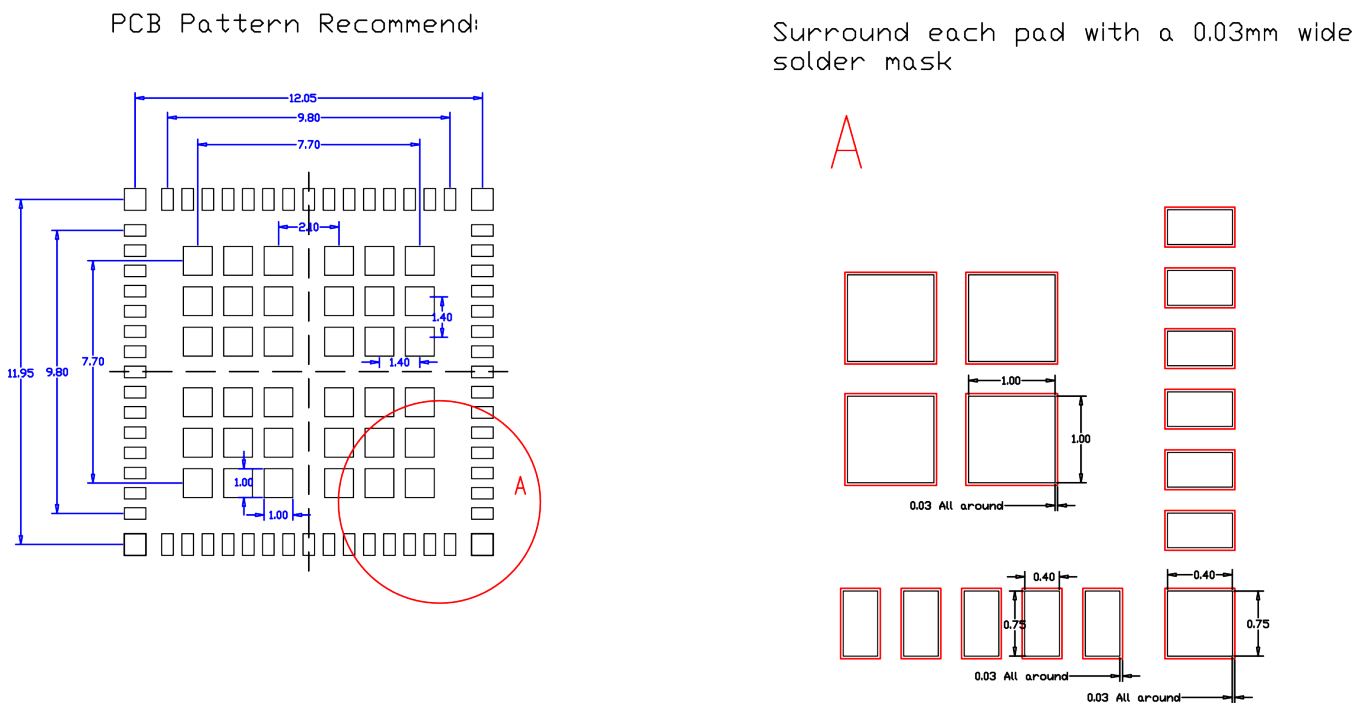

Figure 4-3. Outline of Recommended PCB Pattern for 100-Pin MOC Package

## 4.1 Pin Description

Table 4-1 describes the module pins.

**Table 4-1. Pin Description**

PIN NAME	PIN	TYPE/ DIR	SHUTDOWN STATE	AFTER POWER UP <sup>(1)</sup>	VOLTAGE LEVEL	CONNECTIVITY <sup>(2)</sup>				DESCRIPTION
						1801	1805	1831	1835	
<b>Clocks and Reset Signals</b>										
WL_SDIO_CLK_1V8	8	I	Hi-Z	Hi-Z	1.8 V	v	v	v	v	WLAN SDIO clock. Must be driven by the host.
EXT_32K	36	ANA			–	v	v	v	v	Input sleep clock: 32.768 kHz
WLAN_EN	40	I	PD	PD	1.8 V	v	v	v	v	Mode setting: high = enable
BT_EN	41	I	PD	PD	1.8 V	x	x	v	v	Mode setting: high = enable
<b>Power-Management Signals</b>										
VIO_IN	38	POW	PD	PD	1.8 V	v	v	v	v	Connect to 1.8-V external VIO
VBAT_IN	46	POW			VBAT	v	v	v	v	Power supply input, 2.9 to 4.8 V
VBAT_IN	47	POW			VBAT	v	v	v	v	Power supply input, 2.9 to 4.8 V
<b>TI Reserved</b>										
GPIO11	2	I/O	PD	PD	1.8 V	v	v	v	v	Reserved for future use. NC if not used.
GPIO9	3	I/O	PD	PD	1.8 V	v	v	v	v	Reserved for future use. NC if not used.
GPIO10	4	I/O	PU	PU	1.8 V	v	v	v	v	Reserved for future use. NC if not used.
GPIO12	5	I/O	PU	PU	1.8 V	v	v	v	v	Reserved for future use. NC if not used.
RESERVED1	21	I	PD	PD	1.8 V	x	x	x	x	Reserved for future use. NC if not used.
RESERVED2	22	I	PD	PD	1.8 V	x	x	x	x	Reserved for future use. NC if not used.
GPIO4	25	I/O	PD	PD	1.8 V	v	v	v	v	Reserved for future use. NC if not used.
RESERVED3	62	O	PD	PD	1.8 V	x	x	x	x	Reserved for future use. NC if not used.
RESERVED	64	GND			–	v	v	v	v	Reserved for future use. NC if not used.
<b>WLAN Functional Block: Int Signals</b>										
WL_SDIO_CMD_1V8	6	I/O	Hi-Z	Hi-Z	1.8 V	v	v	v	v	WLAN SDIO command in <sup>(3)</sup>
WL_SDIO_D0_1V8	10	I/O	Hi-Z	Hi-Z	1.8 V	v	v	v	v	WLAN SDIO data bit 0 <sup>(3)</sup>
WL_SDIO_D1_1V8	11	I/O	Hi-Z	Hi-Z	1.8 V	v	v	v	v	WLAN SDIO data bit 1 <sup>(3)</sup>
WL_SDIO_D2_1V8	12	IO	Hi-Z	Hi-Z	1.8 V	v	v	v	v	WLAN SDIO data bit 2 <sup>(3)</sup>

(1) PU = pullup; PD = pulldown.

(2) v = connect; x = no connect.

(3) Host must provide PU using a 10-K resistor for all non-CLK SDIO signals.

Table 4-1. Pin Description (continued)

PIN NAME	PIN	TYPE/ DIR	SHUTDOWN STATE	AFTER POWER UP <sup>(1)</sup>	VOLTAGE LEVEL	CONNECTIVITY <sup>(2)</sup>				DESCRIPTION
						1801	1805	1831	1835	
WL_SDIO_D3_1V8	13	I/O	Hi-Z	PU	1.8 V	v	v	v	v	WLAN SDIO data bit 3. Changes state to PU at WL_EN or BT_EN assertion for card detects. Later disabled by software during initialization. (1)
WL_IRQ_1V8	14	O	PD	0	1.8 V	v	v	v	v	SDIO available, interrupt out. Active high. (For WL_RS232_TX/RX pullup is at power up.) Set to rising edge (active high) on power up. The Wi-Fi interrupt line can be configured by the driver according to the IRQ configuration (polarity/level/edge).
GPIO2	26	I/O	PD	PD	1.8 V	v	v	v	v	WL_RS232_RX (when WLAN_IRQ = 1 at power up)
2G4_ANT2_W	18	ANA			–	x	v	x	v	2.4G ant2 TX, RX
GPIO1	27	I/O	PD	PD	1.8 V	v	v	v	v	WL_RS232_TX (when WLAN_IRQ = 1 at power up)
2G4_ANT1_WB	32	ANA			–	v	v	v	v	2.4G ant1 TX, RX
WL_UART_DBG	42	O	PU	PU	1.8 V	v	v	v	v	Option: WLAN logger
<b>Bluetooth Functional Block: Int Signals</b>										
BT_UART_DBG	43	O	PU	PU	1.8 V	x	x	v	v	Option: Bluetooth logger
BT_HCI_RTS_1V8	50	O	PU	PU	1.8 V	x	x	v	v	UART RTS to host. NC if not used.
BT_HCI_CTS_1V8	51	I	PU	PU	1.8 V	x	x	v	v	UART CTS from host. NC if not used.
BT_HCI_TX_1V8	52	O	PU	PU	1.8 V	x	x	v	v	UART TX to host. NC if not used.
BT_HCI_RX_1V8	53	I	PU	PU	1.8 V	x	x	v	v	UART RX from host. NC if not used.
BT_AUD_IN	56	I	PD	PD	1.8 V	x	x	v	v	Bluetooth PCM/I2S bus. Data in. NC if not used.
BT_AUD_OUT	57	O	PD	PD	1.8 V	x	x	v	v	Bluetooth PCM/I2S bus. Data out. NC if not used.
BT_AUD_FSYNC	58	I/O	PD	PD	1.8 V	x	x	v	v	Bluetooth PCM/I2S bus. Frame sync. NC if not used.
BT_AUD_CLK	60	I/O	PD	PD	1.8 V	x	x	v	v	Bluetooth PCM/I2S bus. NC if not used.



**Table 4-1. Pin Description (continued)**

PIN NAME	PIN	TYPE/ DIR	SHUTDOWN STATE	AFTER POWER UP <sup>(1)</sup>	VOLTAGE LEVEL	CONNECTIVITY <sup>(2)</sup>				DESCRIPTION
						1801	1805	1831	1835	
<b>Ground Pins</b>										
GND	1, 7, 9, 15, 16, 17, 19, 20, 23, 24, 28, 29, 30, 31, 33, 34, 35, 37, 39, 44, 45, 48, 49, 54, 55, 59, 61, 63, G1- G36	GND			–	V	V	V	V	

## 5 Specifications

### 5.1 Absolute Maximum Ratings<sup>(1)</sup>

over operating free-air temperature range (unless otherwise noted)

PARAMETER	VALUE	UNIT
VBAT	4.8 <sup>(2)</sup>	V
VIO	–0.5 to 2.1	V
Input voltage to analog pins	–0.5 to 2.1	V
Input voltage limits (CLK_IN)	–0.5 to VDD_IO	V
Input voltage to all other pins	–0.5 to (VDD_IO + 0.5 V)	V
Operating ambient temperature range	–20 to +70 <sup>(3)</sup>	°C

- Stresses beyond those listed under “absolute maximum ratings” may cause permanent damage to the device. These are stress ratings only and functional operation of the device at these or any other conditions beyond those indicated under “operating conditions” is not implied. Exposure to absolute-maximum-rated conditions for extended periods may affect device reliability.
- 4.8 V cumulative to 2.33 years, including charging dips and peaks
- Operating free-air temperature range at which the device can operate reliably for 15K cumulative active TX power-on hours (assuming a maximum junction temperature of (T<sub>j</sub>) of 125°C). [Section 5.3, Power-On Hours \(POH\)](#), describes the correlation between T<sub>j</sub> and PoH. In the WL18xx system, a control mechanism automatically ensures T<sub>j</sub> < 125°C. Whenever T<sub>j</sub> approaches the threshold, this mechanism controls the transmitter patterns.

### 5.2 Handling Ratings

		MIN	MAX	UNIT
T <sub>stg</sub>	Storage temperature range	–40	+85	°C
ESD stress voltage <sup>(1)</sup>	Human body model (HBM) <sup>(2)</sup>	–1000	+1000	V
	Charged device model (CDM) <sup>(3)</sup>	–250	+250	

- ESD measures device sensitivity and immunity to damage caused by electrostatic discharges into the device.
- The level listed is the passing level per ANSI/ESDA/JEDEC JS-001. JEDEC document JEP155 states that 500-V HBM allows safe manufacturing with a standard ESD control process, and manufacturing with less than 500-V HBM is possible, if necessary precautions are taken. Pins listed as 1000 V can actually have higher performance.
- The level listed is the passing level per EIA-JEDEC JESD22-C101E. JEDEC document JEP157 states that 250-V CDM allows safe manufacturing with a standard ESD control process, and manufacturing with less than 250-V CDM is possible, if necessary precautions are taken. Pins listed as 250 V can actually have higher performance.

### 5.3 Power-On Hours (POH)

OPERATING JUNCTION TEMPERATURE (°C)	POH
125	15,000
120	20,000
115	27,000
110	37,000
105	50,000

### 5.4 Recommended Operating Conditions

over operating free-air temperature range (unless otherwise noted)

		MIN	NOM	MAX	UNIT
VBAT <sup>(1)</sup>	DC supply range for all modes	2.9		4.8	V
	1.8-V I/O ring power supply voltage	1.62		1.95	V
V <sub>IH</sub>	I/O high-level input voltage	0.65 x VDD_IO		VDD_IO	V
V <sub>IL</sub>	I/O low-level input voltage	0		0.35 x VDD_IO	V
VIH_EN	Enable inputs high-level input voltage	1.365		VDD_IO	V

- 4.8 V is applicable only for 2.3 years (30% of the time). Otherwise, maximum VBAT must not exceed 4.3 V.

## Recommended Operating Conditions (continued)

over operating free-air temperature range (unless otherwise noted)

			MIN	NOM	MAX	UNIT
VIL_EN	Enable inputs low-level input voltage		0		0.4	V
V <sub>OH</sub>	High-level output voltage	@ 4 mA	VDD_IO -0.45		VDD_IO	V
V <sub>OL</sub>	Low-level output voltage	@ 4 mA	0		0.45	V
T <sub>r</sub> , T <sub>f</sub>	Input transitions time T <sub>r</sub> , T <sub>f</sub> from 10% to 90% (digital I/O) <sup>(2)</sup>		1		10	ns
T <sub>r</sub>	Output rise time from 10% to 90% (digital pins) <sup>(2)</sup>	C <sub>L</sub> < 25 pF			5.3	ns
T <sub>f</sub>	Output fall time from 10% to 90% (digital pins) <sup>(2)</sup>	C <sub>L</sub> < 25 pF			4.9	ns
	Ambient operating temperature		-20		70	°C
Maximum power dissipation	WLAN operation				2.8	W
	Bluetooth operation				0.2	

(2) Applies to all digital lines except SDIO, UART, I2C, PCM and slow clock lines

## 5.5 External Digital Slow Clock Requirements

The supported digital slow clock is 32.768 kHz digital (square wave). All core functions share a single input.

PARAMETER	CONDITION	SYMBOL	MIN	TYP	MAX	UNIT
Input slow clock frequency				32768		Hz
Input slow clock accuracy (Initial + temp + aging)	WLAN, Bluetooth				±250	ppm
Input transition time T <sub>r</sub> , T <sub>f</sub> (10% to 90%)		T <sub>r</sub> , T <sub>f</sub>			200	ns
Frequency input duty cycle			15	50	85	%
Input voltage limits	Square wave, DC-coupled	V <sub>ih</sub>	0.65 x VDD_IO		VDD_IO	V <sub>peak</sub>
		V <sub>il</sub>	0		0.35 x VDD_IO	
Input impedance			1			MΩ
Input capacitance					5	pF

## 5.6 Thermal Characteristics

AIR FLOW		
NAME	DESCRIPTION	FCBGA (°C/W) <sup>(1)</sup>
θ <sub>JC</sub>	Junction to case	12.7
θ <sub>JB</sub>	Junction to board	13.6
θ <sub>JA</sub>	Junction to free air <sup>(2)</sup>	20.5
φ <sub>JB</sub>	Junction to board	8.7

(1) °C/W = degrees Celsius per watt

(2) According to the JEDEC EIA/JESD 51 document

## 5.7 WLAN Performance

All RF and performance numbers are aligned to the module pin.

### 5.7.1 WLAN 2.4-GHz Receiver Characteristics

over operating free-air temperature range (unless otherwise noted)

PARAMETER	CONDITION	MIN	TYP	MAX	UNIT
Operation frequency range	2400 to 2480	2400		2480	MHz
Sensitivity: 20-MHz bandwidth. At < 10% PER limit	1 Mbps DSSS		–96.3		dBm
	2 Mbps DSSS		–93.2		
	5.5 Mbps CCK		–90.6		
	11 Mbps CCK		–87.9		
	6 Mbps OFDM		–92.0		
	9 Mbps OFDM		–90.4		
	12 Mbps OFDM		–89.5		
	18 Mbps OFDM		–87.2		
	24 Mbps OFDM		–84.1		
	36 Mbps OFDM		–80.7		
	48 Mbps OFDM		–76.5		
	54 Mbps OFDM		–74.9		
	MCS0 MM 4K		–90.4		
	MCS1 MM 4K		–87.6		
	MCS2 MM 4K		–85.9		
	MCS3 MM 4K		–82.8		
	MCS4 MM 4K		–79.4		
	MCS5 MM 4K		–75.2		
	MCS6 MM 4K		–73.5		
	MCS7 MM 4K		–72.4		
MCS0 MM 4K 40 MHz		–86.7			
MCS7 MM 4K 40 MHz		–67.0			
MCS0 MM 4K MRC		–92.7			
MCS7 MM 4K MRC		–75.2			
MCS13 MM 4K		–73.7			
MCS14 MM 4K		–72.3			
MCS15 MM 4K		–71.0			
Max Input Level At < 10% PER limit	OFDM (11g/n)	–19	–9		dBm
	DSSS	–4	–0		dBm
Adjacent channel rejection: Sensitivity level +3 dB for OFDM; Sensitivity level +6 dB for 11b	2 Mbps DSSS	42.7			dB
	11 Mbps CCK	37.9			dB
	54 Mbps OFDM	2.0			dB

### 5.7.2 WLAN 2.4-GHz Transmitter Power

over operating free-air temperature range (unless otherwise noted)

PARAMETER	CONDITION	MIN	TYP	MAX	UNIT
<b>RF_IO2_BG_WL pin 2.4-GHz SISO</b>					
Output Power: Maximum RMS output power measured at 1 dB from IEEE spectral mask or EVM <sup>(1)</sup>	1 Mbps DSSS		17.3		dBm
	2 Mbps DSSS		17.3		
	5.5 Mbps CCK		17.3		
	11 Mbps CCK		17.3		
	6 Mbps OFDM		17.1		
	9 Mbps OFDM		17.1		
	12 Mbps OFDM		17.1		
	18 Mbps OFDM		17.1		
	24 Mbps OFDM		16.2		
	36 Mbps OFDM		15.3		
	48 Mbps OFDM		14.6		
	54 Mbps OFDM		13.8		
	MCS0 MM		16.1		
	MCS1 MM		16.1		
	MCS2 MM		16.1		
	MCS3 MM		16.1		
	MCS4 MM		15.3		
	MCS5 MM		14.6		
	MCS6 MM		13.8		
	MCS7 MM <sup>(2)</sup>		12.6		
MCS0 MM 40 MHz		14.8			
MCS7 MM 40 MHz		11.3			
<b>2G4_ANT2_W + 2G4_ANT1_WB 2.4-GHz MIMO</b>					
	MCS12 (WL18x5)		18.5		dBm
	MCS13 (WL18x5)		17.4		
	MCS14 (WL18x5)		14.5		
	MCS15 (WL18x5)		13.4		
<b>2G4_ANT2_W + 2G4_ANT1_WB Pins</b>					
Operation frequency range		2412		2484	MHz
Return loss			-10.0		dB
Reference input impedance			50.0		Ω

- (1) Regulatory constraints limit TI module output power to the following:
- Channels 1, 11, 13 @ OFDM legacy and HT 20-MHz rates: 14 dBm
  - Channels 1, 11, 13 @ HT 40-MHz lower primary rates: 12 dBm
  - Channel 7 @ HT 40-MHz lower primary rates: 12 dBm
  - Channel 5 @ HT 40-MHz upper primary rates: 12 dBm
- (2) To ensure compliance with the EVM conditions specified in the PHY chapter of IEEE Std 802.11™ – 2012:
- MCS7 20 MHz channel 12 output power is 2 dB lower than the typical value.
  - MCS7 20 MHz channel 8 output power is 1 dB lower than the typical value.

### 5.7.3 WLAN Currents

	SPECIFICATION ITEMS	TYP (AVG) – 25°C	UNITS
Receiver	Low-power mode (LPM) 2.4-GHz RX SISO20 single chain	49	mA
	2.4 GHz RX search SISO20	54	mA
	2.4-GHz RX search MIMO20	74	mA
	2.4-GHz RX search SISO40	59	mA
	2.4-GHz RX 20 M SISO 11 CCK	56	mA
	2.4-GHz RX 20 M SISO 6 OFDM	61	mA
	2.4-GHz RX 20 M SISO MCS7	65	mA
	2.4-GHz RX 20 M MRC 1 DSSS	74	mA
	2.4-GHz RX 20 M MRC 6 OFDM	81	mA
	2.4-GHz RX 20 M MRC 54 OFDM	85	mA
	2.4-GHz RX 40 MHz MCS7	77	mA
Transmitter	2.4-GHz TX 20 M SISO 6 OFDM 15.4 dBm	285	mA
	2.4-GHz TX 20 M SISO 11 CCK 15.4 dBm	273	mA
	2.4-GHz TX 20 M SISO 54 OFDM 12.7 dBm	247	mA
	2.4-GHz TX 20 M SISO MCS7 11.2 dBm	238	mA
	2.4-GHz TX 20 M MIMO MCS15 11.2 dBm	420	mA
	2.4-GHz TX 40 M SISO MCS7 8.2 dBm	243	mA

### 5.8 Bluetooth Performance

All RF and performance numbers are aligned to the module pin.

#### 5.8.1 Bluetooth BR, EDR Receiver Characteristics—In-Band Signals

over operating free-air temperature range (unless otherwise noted)

PARAMETER	CONDITION	MIN	TYP	MAX	UNIT
Bluetooth BR, EDR operation frequency range		2402		2480	MHz
Bluetooth BR, EDR channel spacing			1		MHz
Bluetooth BR, EDR input impedance			50		Ω
Bluetooth BR, EDR sensitivity <sup>(1)</sup> dirty TX on	BR, BER = 0.1%		–92.2		dBm
	EDR2, BER = 0.01%		–91.7		dBm
	EDR3, BER = 0.01%		–84.7		dBm
Bluetooth EDR BER floor at sensitivity + 10 dB Dirty TX off (for 1,600,000 bits)	EDR2	1e-6			
	EDR3	1e-6			
Bluetooth BR, EDR maximum usable input power	BR, BER = 0.1%	–5.0			dBm
	EDR2, BER = 0.1%	–15.0			dBm
	EDR3, BER = 0.1%	–15.0			dBm
Bluetooth BR intermodulation	Level of interferers for n = 3, 4, and 5	–36.0	–30.0		dBm

(1) Sensitivity degradation up to –3 dB may occur due to fast clock harmonics with dirty TX on.

PARAMETER	CONDITION		MIN	TYP	MAX	UNIT
Bluetooth BR, EDR C/I performance Numbers show wanted signal-to-interfering-signal ratio. Smaller numbers indicate better C/I performances (Image frequency = -1 MHz)	BR, co-channel				10	dB
	EDR, co-channel	EDR2			12	dB
		EDR3			20	dB
	BR, adjacent ±1 MHz				-3.0	dB
	EDR, adjacent ±1 MHz, (image)	EDR2			-3.0	dB
		EDR3			2.0	dB
	BR, adjacent +2 MHz				-33.0	dB
	EDR, adjacent +2 MHz	EDR2			-33.0	dB
		EDR3			-28.0	dB
	BR, adjacent -2 MHz				-20.0	dB
	EDR, adjacent -2 MHz	EDR2			-20.0	dB
		EDR3			-13.0	dB
BR, adjacent ≥ ±3  MHz				-42.0	dB	
EDR, adjacent ≥ ±3  MHz	EDR2			-42.0	dB	
	EDR3			-36.0	dB	
Bluetooth BR, EDR RF return loss				-10.0		dB

### 5.8.2 Bluetooth Transmitter, BR

over operating free-air temperature range (unless otherwise noted)

PARAMETER	CONDITION	MIN	TYP	MAX	UNIT
BR RF output power <sup>(1)</sup>	V <sub>BAT</sub> ≥ 3 V		12.7		dBm
	V <sub>BAT</sub> < 3 V		7.2		dBm
BR gain control range			30.0		dB
BR power control step			5.0		dB
BR adjacent channel power  M-N  = 2			-43.0		dBm
BR adjacent channel power  M-N  > 2			-48.0		dBm

(1) Values reflect maximum power. Reduced power is available using a vendor-specific (VS) command.

### 5.8.3 Bluetooth Transmitter, EDR

over operating free-air temperature range (unless otherwise noted)

PARAMETER	CONDITION	MIN	TYP	MAX	UNIT
EDR output power <sup>(1)</sup>	V <sub>BAT</sub> ≥ 3 V		7.2		dBm
	V <sub>BAT</sub> < 3 V		5.2		
EDR relative power					dB
EDR gain control range			30		dB
EDR power control step			5		dB
EDR adjacent channel power  M-N  = 1			-36		dBc
EDR adjacent channel power  M-N  = 2			-30		dBm
EDR adjacent channel power  M-N  > 2			-42		dBm

(1) Values reflect default maximum power. Max power can be changed using a VS command.

### 5.8.4 Bluetooth Modulation, BR

over operating free-air temperature range (unless otherwise noted)

CHARACTERISTICS	CONDITION <sup>(1)</sup>		MIN	TYP	MAX	UNIT
BR –20 dB bandwidth				925	995	kHz
BR modulation characteristics	$\Delta f_{1avg}$	Mod data = 4 1s, 4 0s: 111100001111...	145	160	170	kHz
	$\Delta f_{2max} \geq$ limit for at least 99.9% of all $\Delta f_{2max}$	Mod data = 1010101...	120	130		kHz
	$\Delta f_{2avg}, \Delta f_{1avg}$		85	88		%
BR carrier frequency drift	One slot packet		–25		25	kHz
	Three and five slot packet		–35		35	kHz
BR drift rate	$f_{k+5} - f_k, k = 0 \dots \text{max}$				15	kHz/50 $\mu$ s
BR initial carrier frequency tolerance <sup>(2)</sup>	$f_0 - f_{TX}$		$\pm 75$		$\pm 75$	kHz

(1) Performance values reflect maximum power.

(2) Numbers include XTAL frequency drift over temperature and aging.

### 5.8.5 Bluetooth Modulation, EDR

over operating free-air temperature range (unless otherwise noted)

PARAMETER <sup>(1)</sup>	CONDITION	MIN	TYP	MAX	UNIT
EDR carrier frequency stability		–5		5	kHz
EDR initial carrier frequency tolerance <sup>(2)</sup>		$\pm 75$		$\pm 75$	kHz
EDR RMS DEVM	EDR2		4	15	%
	EDR3		4	10	%
EDR 99% DEVM	EDR2			30	%
	EDR3			20	%
EDR peak DEVM	EDR2		9	25	%
	EDR3		9	18	%

(1) Performance values reflect maximum power.

(2) Numbers include XTAL frequency drift over temperature and aging.

## 5.9 Bluetooth LE Performance

All RF and performance numbers are aligned to the module pin.

### 5.9.1 Bluetooth LE Receiver Characteristics – In-Band Signals

over operating free-air temperature range (unless otherwise noted)

PARAMETER	CONDITION <sup>(1)</sup>	MIN	TYP	MAX	UNIT
Bluetooth LE operation frequency range		2402		2480	MHz
Bluetooth LE channel spacing			2		MHz
Bluetooth LE input impedance			50		$\Omega$
Bluetooth LE sensitivity <sup>(2)</sup> Dirty TX on			–92.2		dBm
Bluetooth LE maximum usable input power		–5			dBm
Bluetooth LE intermodulation characteristics	Level of interferers. For n = 3, 4, 5	–36	–30		dBm

(1) BER of 0.1% corresponds to PER of 30.8% for a minimum of 1500 transmitted packets, according to the Bluetooth LE test specification.

(2) Sensitivity degradation of up to –3 dB can occur due to fast clock harmonics.



PARAMETER	CONDITION <sup>(1)</sup>	MIN	TYP	MAX	UNIT
Bluetooth LE C/I performance. Note: Numbers show wanted signal-to-interfering-signal ratio. Smaller numbers indicate better C/I performance.	LE, co-channel			12	dB
	LE, adjacent ±1 MHz			0	
	LE, adjacent +2 MHz			-38	
	LE, adjacent -2 MHz			-15	
Image = -1 MHz	LE, adjacent ≥  ±3 MHz			-40	

### 5.9.2 Bluetooth LE Transmitter Characteristics

over operating free-air temperature range (unless otherwise noted)

PARAMETER		MIN	TYP	MAX	UNIT
Bluetooth LE RF output power <sup>(1)</sup>	VBAT ≥ 3 V		10.0		dBm
	VBAT < 3 V		7.2		dBm
Bluetooth LE adjacent channel power  M-N  = 2			-51.0		dBm
Bluetooth LE adjacent channel power  M-N  > 2			-54.0		dBm

(1) To reduce the maximum BLE power, use a VS command. The optional extra margin is offered to compensate for design losses, such as trace and filter losses, and to achieve the maximum allowed output power at system level.

### 5.9.3 Bluetooth LE Modulation Characteristics

over operating free-air temperature range (unless otherwise noted)

CHARACTERISTICS	CONDITION <sup>(1)</sup>		MIN	TYP	MAX	UNIT
Bluetooth LE modulation characteristics	Δf1avg	Mod data = 4 1s, 4 0s: 111100001111...	240	250	260	kHz
	Δf2max ≥ limit for at least 99.9% of all Δf2max	Mod data = 1010101...	195	215		kHz
	Δf2avg, Δf1avg		85	90		%
Bluetooth LE carrier frequency drift	lf0 – fnl , n = 2,3 .... K		-25		25	kHz
Bluetooth LE drift rate	lf1 – f0l and lfn – fn-5l , n = 6,7.... K				15	kHz/50 μs
LE initial carrier frequency tolerance <sup>(2)</sup>	fn – fTX		±75		±75	kHz

(1) Performance values reflect maximum power.

(2) Numbers include XTAL frequency drift over temperature and aging.

### 5.10 Bluetooth-BLE Dynamic Currents

Current is measured at output power as follows:

- BR at 12.7 dBm
- EDR at 7.2 dBm

USE CASE <sup>(1) (2)</sup>	TYP	UNIT
BR voice HV3 + sniff	11.6	mA
EDR voice 2-EV3 no retransmission + sniff	5.9	mA
Sniff 1 attempt 1.28 s	178.0	μA
EDR A2DP EDR2 (master). SBC high quality – 345 Kbs	10.4	mA
EDR A2DP EDR2 (master). MP3 high quality – 192 Kbs	7.5	mA
Full throughput ACL RX: RX-2DH5 <sup>(3)(4)</sup>	18.0	mA
Full throughput BR ACL TX: TX-DH5 <sup>(4)</sup>	50.0	mA
Full throughput EDR ACL TX: TX-2DH5 <sup>(4)</sup>	33.0	mA

(1) The role of Bluetooth in all scenarios except A2DP is slave.

(2) CL1P5 PA is connected to VBAT, 3.7 V.

(3) ACL RX has the same current in all modulations.

(4) Full throughput assumes data transfer in one direction.

USE CASE <sup>(1) (2)</sup>	TYP	UNIT
Page scan or inquiry scan (scan interval is 1.28 s or 11.25 ms, respectively)	253.0	μA
Page scan and inquiry scan (scan interval is 1.28 s and 2.56 s, respectively)	332.0	μA

### 5.11 Bluetooth LE Currents

All current measured at output power of 7.2 dBm

USE CASE <sup>(1)</sup>	TYP	UNIT
Advertising, not connectable <sup>(2)</sup>	131	μA
Advertising, discoverable <sup>(2)</sup>	143	μA
Scanning <sup>(3)</sup>	266	μA
Connected, master role, 1.28-s connect interval <sup>(4)</sup>	124	μA
Connected, slave role, 1.28-s connect interval <sup>(4)</sup>	132	μA

- (1) CL1p% PA is connected to VBAT, 3.7 V.
- (2) Advertising in all three channels, 1.28-s advertising interval, 15 bytes advertise data
- (3) Listening to a single frequency per window, 1.28-s scan interval, 11.25-ms scan window
- (4) Zero slave connection latency, empty TX and RX LL packets

### 5.12 Timing and Switching Characteristics

#### 5.12.1 Power Management

##### 5.12.1.1 Block Diagram – Internal DC2DCs

The device incorporates three internal DC2DCs (switched-mode power supplies) to provide efficient internal supplies, derived from V<sub>BAT</sub>.

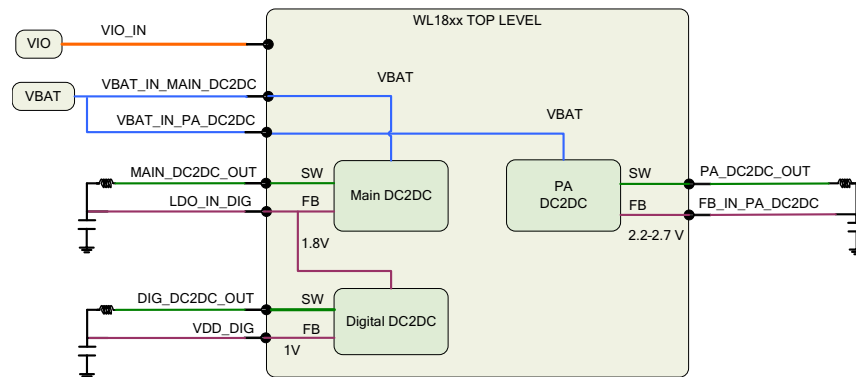

Figure 5-1. Internal DC2DCs

#### 5.12.2 Power-Up and Shut-Down States

The correct power-up and shut-down sequences must be followed to avoid damage to the device.

While V<sub>BAT</sub> or V<sub>IO</sub> or both are deasserted, no signals should be driven to the device. The only exception is the slow clock that is a fail-safe I/O.

While V<sub>BAT</sub>, V<sub>IO</sub>, and slow clock are fed to the device, but WL\_EN is deasserted (low), the device is in SHUTDOWN state. In SHUTDOWN state all functional blocks, internal DC2DCs, clocks, and LDOs are disabled.

To perform the correct power-up sequence, assert (high) WL\_EN. The internal DC2DCs, LDOs, and clock start to ramp and stabilize. Stable slow clock, V<sub>IO</sub>, and V<sub>BAT</sub> are prerequisites to the assertion of one of the enable signals.

To perform the correct shut-down sequence, deassert (low) WL\_EN while all the supplies to the device ( $V_{BAT}$ ,  $V_{IO}$ , and slow clock) are still stable and available. The supplies to the chip ( $V_{BAT}$  and  $V_{IO}$ ) can be deasserted only after both enable signals are deasserted (low).

Figure 5-2 shows the general power scheme for the module, including the powerdown sequence.

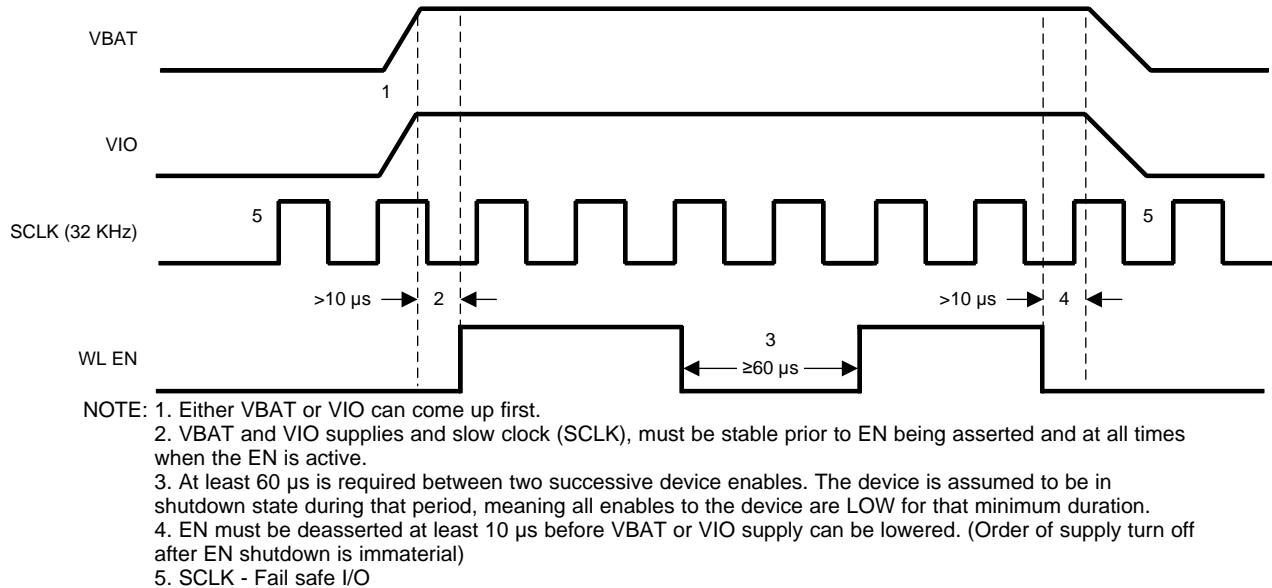

Figure 5-2. Power-Up System

### 5.12.3 Chip Top-level Power-Up Sequence

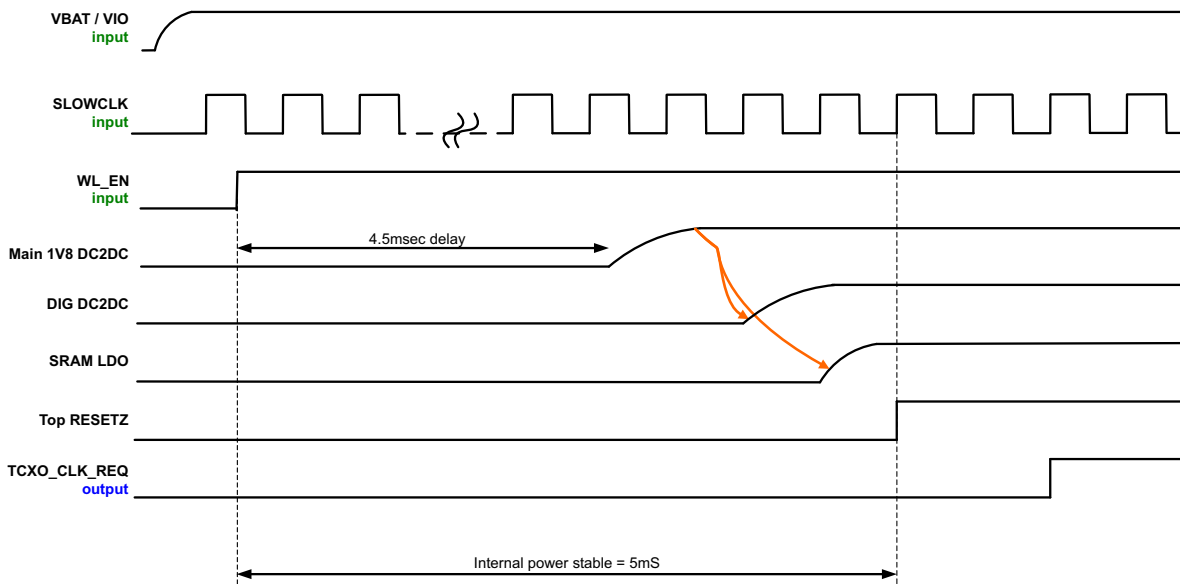

Figure 5-3. Chip Top-Level Power-Up Sequence

### 5.12.4 WLAN Power-Up Sequence

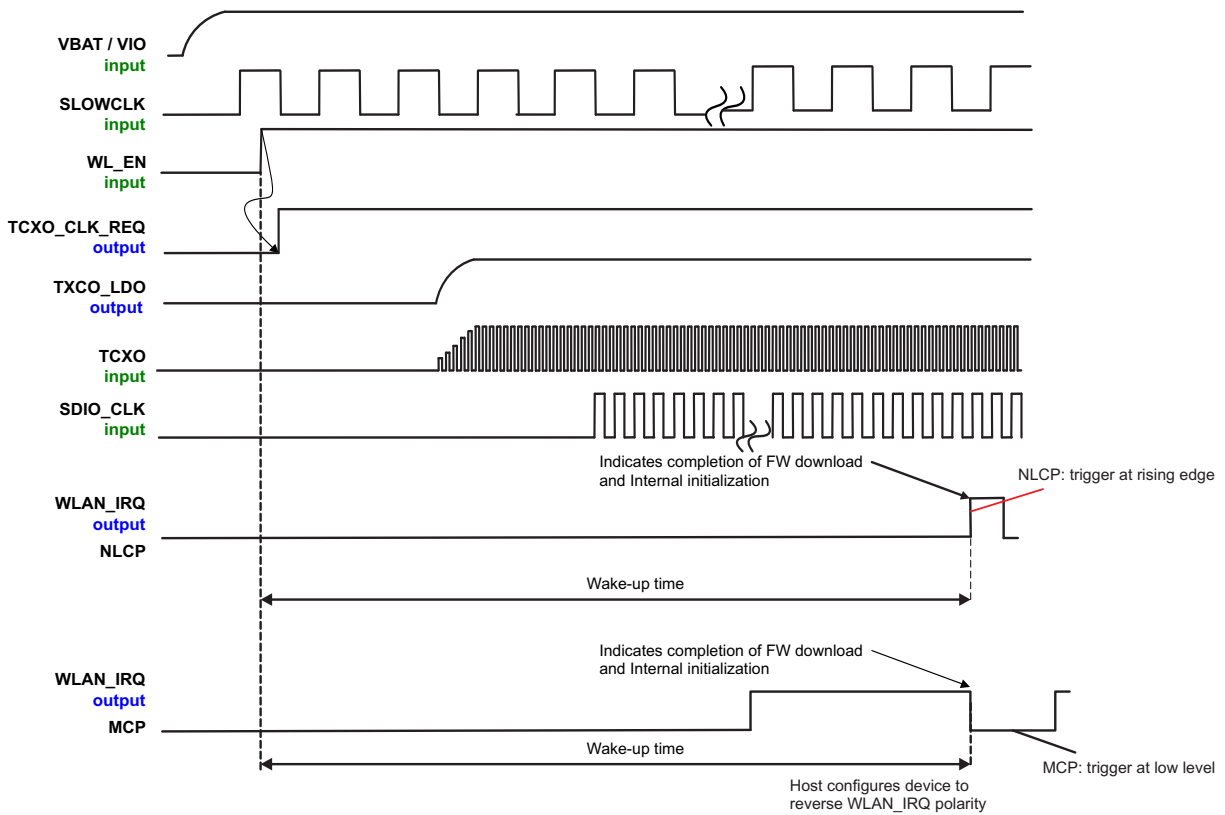

Figure 5-4. WLAN Power-Up Sequence

### 5.12.5 Bluetooth-BLE Power-Up Sequence

Figure 5-5 shows the Bluetooth-BLE power-up sequence.

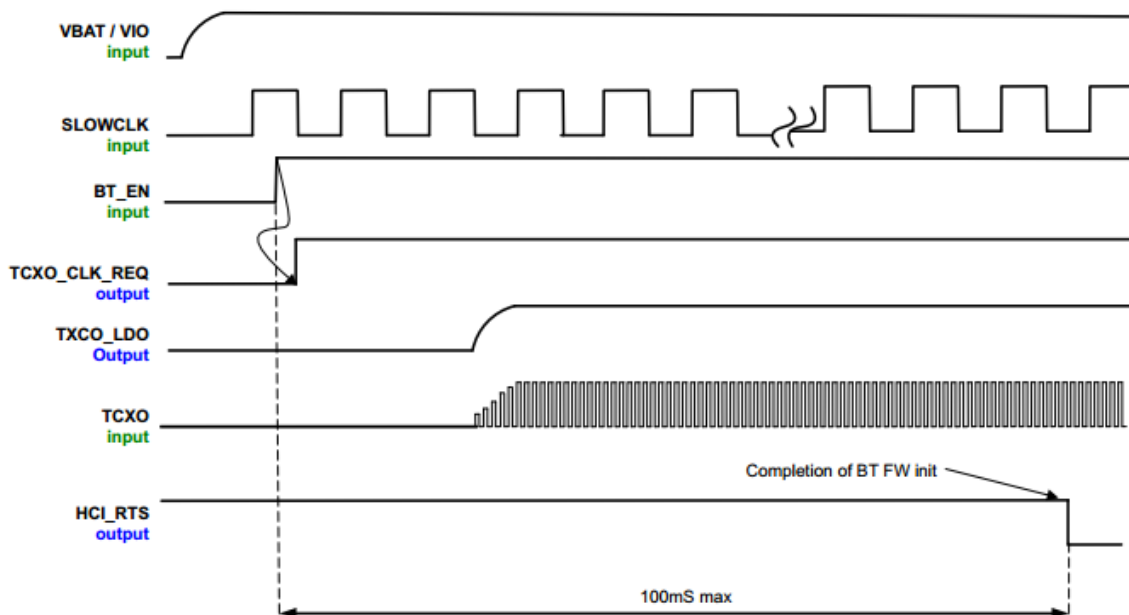

Figure 5-5. Bluetooth/BLE Power-Up Sequence

### 5.12.6 WLAN SDIO Transport Layer

The SDIO is the host interface for WLAN. The interface between the host and the WL18xx module uses an SDIO interface and supports a maximum clock rate of 50 MHz.

The device SDIO also supports the following features of the SDIO V3 specification:

- 4-bit data bus
- Synchronous and asynchronous in-band interrupt
- Default and high-speed (HS, 50 MHz) timing
- Sleep and wake commands

#### 5.12.6.1 SDIO Timing Specifications

Figure 5-6 and Figure 5-7 show the SDIO switching characteristics over recommended operating conditions and with the default rate for input and output.

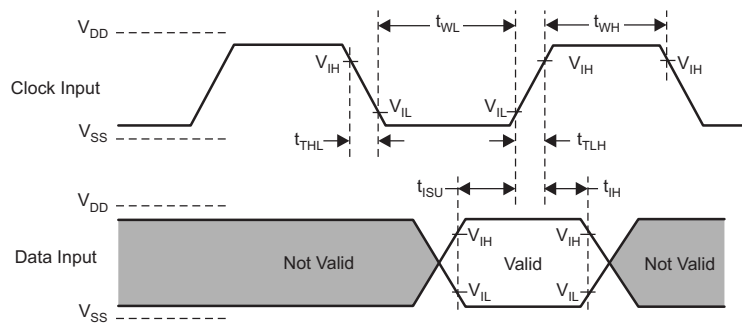

Figure 5-6. SDIO Default Input Timing

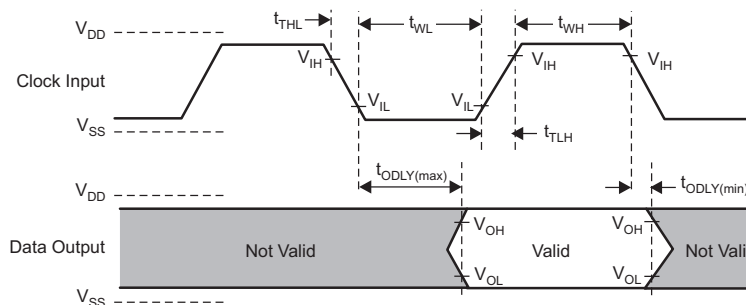

Figure 5-7. SDIO Default Output Timing

Table 5-1 lists the SDIO default timing characteristics.

Table 5-1. SDIO Default Timing Characteristics<sup>(1)</sup>

PARAMETER <sup>(2)</sup>		MIN	MAX	UNIT
$f_{\text{clock}}$	Clock frequency, CLK	0.0	26.0	MHz
DC	Low, high duty cycle	40.0	60.0	%
$t_{\text{TLH}}$	Rise time, CLK		10.0	ns
$t_{\text{THL}}$	Fall time, CLK		10.0	ns
$t_{\text{ISU}}$	Setup time, input valid before CLK $\uparrow$	3.0		ns
$t_{\text{IH}}$	Hold time, input valid after CLK $\uparrow$	2.0		ns
$t_{\text{ODLY}}$	Delay time, CLK $\downarrow$ to output valid	7.0	10.0	ns
$C_i$	Capacitive load on outputs		15.0	pF

(1) To change the data out clock edge from the falling edge (default) to the rising edge, set the configuration bit.

(2) Parameter values reflect maximum clock frequency.

**5.12.6.2 SDIO Switching Characteristics – High Rate**

Figure 5-8 and Figure 5-9 show the parameters for maximum clock frequency.

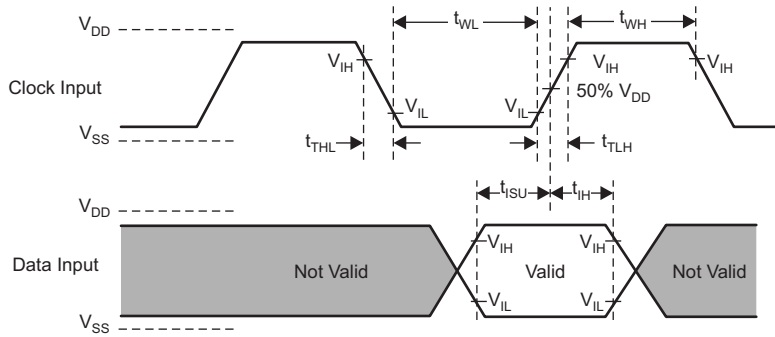

**Figure 5-8. SDIO HS Input Timing**

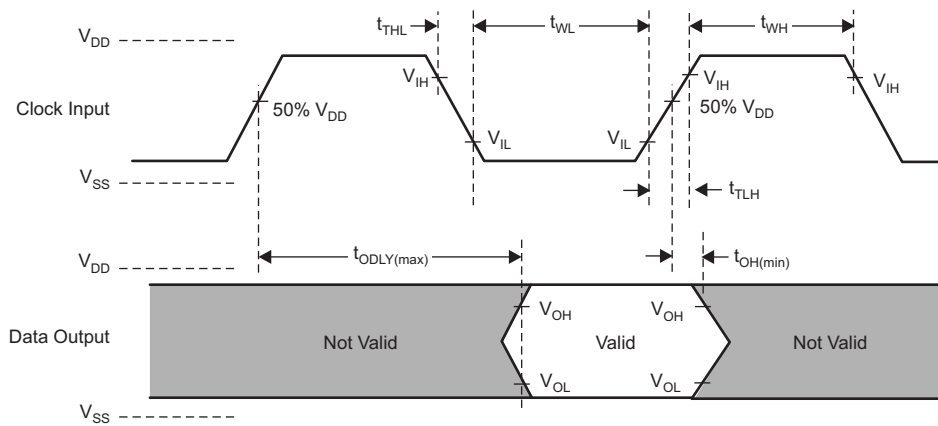

**Figure 5-9. SDIO HS Output Timing**

Table 5-2 lists the SDIO high-rate timing characteristics.

**Table 5-2. SDIO HS Timing Characteristics**

PARAMETER		MIN	MAX	UNIT
$f_{clock}$	Clock frequency, CLK	0.0	52.0	MHz
DC	Low, high duty cycle	40.0	60.0	%
$t_{TLH}$	Rise time, CLK		3.0	ns
$t_{THL}$	Fall time, CLK		3.0	ns
$t_{SU}$	Setup time, input valid before CLK $\uparrow$	3.0		ns
$t_{H}$	Hold time, input valid after CLK $\uparrow$	2.0		ns
$t_{ODLY}$	Delay time, CLK $\uparrow$ to output valid	7.0	10.0	ns
$C_I$	Capacitive load on outputs		10.0	pF

**5.12.7 HCI UART Shared Transport Layers for All Functional Blocks (Except WLAN)**

The device incorporates a UART module dedicated to the *Bluetooth* shared-transport, host controller interface (HCI) transport layer. The HCI interface transports commands, events, and ACL between the *Bluetooth* device and its host using HCI data packets acting as a shared transport for all functional blocks except WLAN.

WLAN	SHARED HCI FOR ALL FUNCTIONAL BLOCKS EXCEPT WLAN	BLUETOOTH VOICE-AUDIO
WLAN HS SDIO	Over UART	<i>Bluetooth</i> PCM

The HCI UART supports most baud rates (including all PC rates) for all fast-clock frequencies up to a maximum of 4 Mbps. After power up, the baud rate is set for 115.2 kbps, regardless of the fast-clock frequency. The baud rate can then be changed using a VS command. The device responds with a Command Complete Event (still at 115.2 kbps), after which the baud rate change occurs.

HCI hardware includes the following features:

- Receiver detection of break, idle, framing, FIFO overflow, and parity error conditions
- Receiver-transmitter underflow detection
- CTS, RTS hardware flow control
- 4 wire (H4)

Table 5-3 lists the UART default settings.

Table 5-3. UART Default Setting

PARAMETER	VALUE
Bit rate	115.2 kbps
Data length	8 bits
Stop bit	1
Parity	None

### 5.12.7.1 UART 4-Wire Interface – H4

The interface includes four signals:

- TXD
- RXD
- CTS
- RTS

Flow control between the host and the device is byte-wise by hardware.

When the UART RX buffer of the device passes the flow-control threshold, the buffer sets the UART\_RTS signal high to stop transmission from the host. When the UART\_CTS signal is set high, the device stops transmitting on the interface. If HCI\_CTS is set high in the middle of transmitting a byte, the device finishes transmitting the byte and stops the transmission.

Figure 5-10 shows the UART timing.

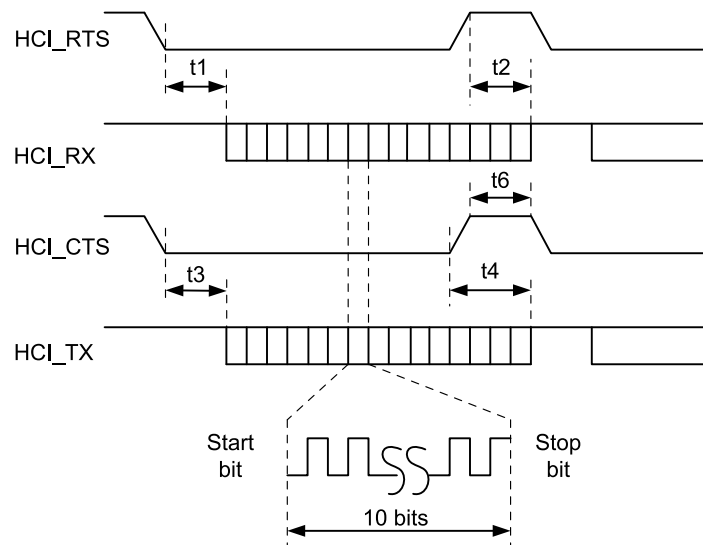

Figure 5-10. UART Timing Diagram

Table 5-4 lists the UART timing characteristics.

**Table 5-4. UART Timing Characteristics**

PARAMETER	CONDITION	SYMBOL	MIN	TYP	MAX	UNIT
Baud rate			37.5		4364	Kbps
Baud rate accuracy per byte	Receive-transmit		-2.5		+1.5	%
Baud rate accuracy per bit	Receive-transmit		-12.5		+12.5	%
CTS low to TX_DATA on		t3	0.0	2.0		µs
CTS high to TX_DATA off	Hardware flow control	t4			1.0	Byte
CTS high pulse width		t6	1.0			Bit
RTS low to RX_DATA on		t1	0.0	2.0		µs
RTS high to RX_DATA off	Interrupt set to 1/4 FIFO	t2			16.0	Bytes

Figure 5-11 shows the UART data frame.

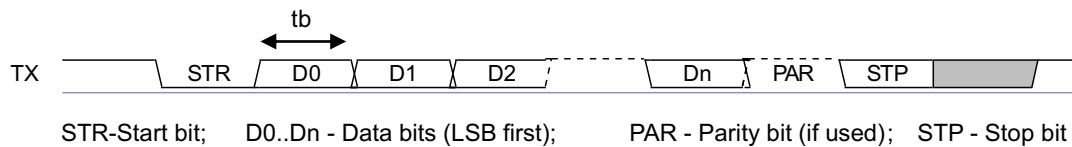

**Figure 5-11. UART Data Frame**

**5.12.8 Bluetooth Codec-PCM (Audio) Timing Specifications**

Figure 5-12 shows the Bluetooth codec-PCM (audio) timing diagram.

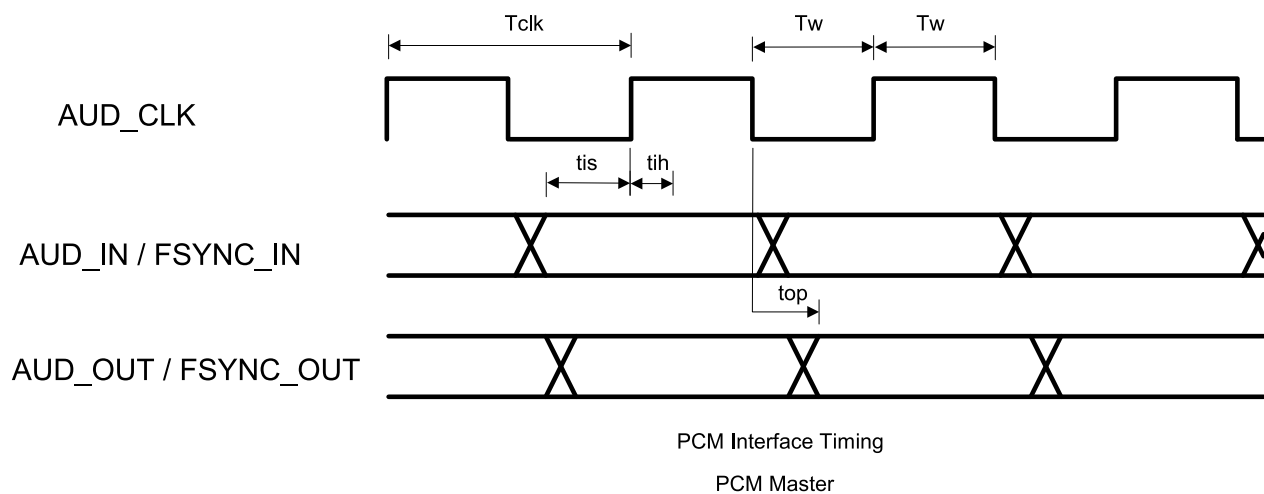

**Figure 5-12. Bluetooth Codec-PCM (Audio) Master Timing Diagram**



Table 5-5 lists the *Bluetooth* codec-PCM master timing characteristics.

**Table 5-5. *Bluetooth* Codec-PCM Master Timing Characteristics**

PARAMETER	SYMBOL	MIN	MAX	UNIT
Cycle time	$T_{clk}$	162.76 (6.144 MHz)	15625 (64 kHz)	ns
High or low pulse width	$T_s$	35% of $T_{clk}$ min		
AUD_IN setup time	$t_{is}$	10.6		
AUD_IN hold time	$t_{ih}$	0		
AUD_OUT propagation time	$t_{op}$	0	15	
FSYNC_OUT propagation time	$t_{op}$	0	15	
Capacitive loading on outputs	$C_l$		40	pF

Table 5-6 lists the *Bluetooth* codec-PCM slave timing characteristics.

**Table 5-6. *Bluetooth* Codec-PCM Slave Timing Characteristics**

PARAMETER	SYMBOL	MIN	MAX	UNIT
Cycle time	$T_{clk}$	81.38 (12.266 MHz)		ns
High or low pulse width	$T_w$	35% of $T_{clk}$ min		
AUD_IN setup time	$t_{is}$	5		
AUD_IN hold time	$t_{ih}$	0		
AUD_FSYNC setup time	$t_{is}$	5		
AUD_FSYNC hold time	$t_{ih}$	0		
AUD_OUT propagation time	$t_{op}$	0	19	
Capacitive loading on outputs	$C_l$		40	pF

## 6 Detailed Description

The WiLink 8 module is a self-contained connectivity solution based on WiLink 8 connectivity. As the eighth-generation connectivity combo chip from TI, the WiLink 8 module is based on proven technology.

Table 6-1 through Table 6-3 list performance parameters along with shutdown and sleep currents.

**Table 6-1. WLAN Performance Parameters**

WLAN <sup>(1)</sup>	SPECIFICATION (TYP)	CONDITIONS
Maximum TX power	17.3 dBm	1 Mbps DSSS
Minimum sensitivity	–96.3 dBm	1 Mbps DSSS
Sleep current	160 µA	Leakage, firmware retained
Connected IDLE	750 µA	No traffic IDLE connect
RX search	54 mA	Search (SISO20)
RX current (SISO20)	65 mA	MCS7, 2.4 GHz
TX current (SISO20) <sup>(2)</sup>	238 mA	MCS7, 2.4 GHz, +11.2 dBm
Maximum peak current consumption during calibration <sup>(3)</sup>	850 mA	

- (1) System design power scheme must comply with both peak and average TX bursts.
- (2) WLAN maximum VBAT current draw of 725 mA with MIMO continues burst configuration.
- (3) Peak current VBAT can hit 850 mA during device calibration.
  - At wakeup, the WiLink 8 module performs the entire calibration sequence at the center of the 2.4-GHz band.
  - Once a link is established, calibration is performed periodically (every 5 minutes) on the specific channel tuned.
  - The maximum VBAT value is based on peak calibration consumption with a 30% margin.

**Table 6-2. Bluetooth Performance Parameters**

BLUETOOTH	SPECIFICATION (TYP)	CONDITIONS
Maximum TX power	12.7 dBm	GFSK
Minimum sensitivity	–92.2 dBm	GFSK
Sniff	178 µA	1 attempt, 1.28 s (+4 dBm)
Page or inquiry	253 µA	1.28-s interrupt, 11.25-ms scan window (+4 dBm)
A2DP	7.5 mA	MP3 high quality 192 kbps (+4 dBm)

**Table 6-3. Shutdown and Sleep Currents**

PARAMETER	POWER SUPPLY CURRENT	TYP	UNIT
Shutdown mode All functions shut down	VBAT	10	µA
	VIO	2	µA
WLAN sleep mode	VBAT	160	µA
Bluetooth sleep mode	VBAT	110	µA

Figure 6-1 shows a high-level view of the WL1835MOD variant.

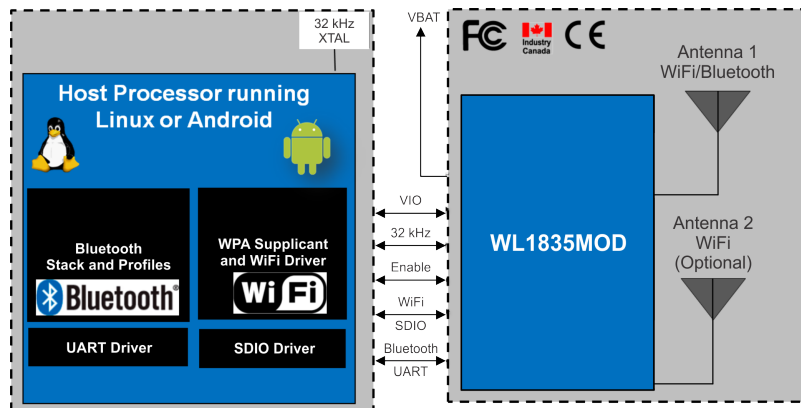

Figure 6-1. WL1835MOD High-Level System Diagram

## 6.1 WLAN

The device supports the following WLAN features:

- Integrated 2.4-GHz power amplifiers (PAs) for a complete WLAN solution
- Baseband processor: IEEE Std 802.11b/g and IEEE Std 802.11n data rates with 20- or 40-MHz SISO and 20-MHz MIMO
- Fully calibrated system (production calibration not required)
- Medium access controller (MAC)
  - Embedded ARM® central processing unit (CPU)
  - Hardware-based encryption-decryption using 64-, 128-, and 256-bit WEP, TKIP, or AES keys
  - Requirements for Wi-Fi-protected access (WPA and WPA2.0) and IEEE Std 802.11i (includes hardware-accelerated Advanced Encryption Standard [AES])
- New advanced coexistence scheme with *Bluetooth* and BLE
- 2.4-GHz radio
  - Internal LNA and PA
  - IEEE Std 802.11b, 802.11g, and 802.11n
- 4-bit SDIO host interface, including high speed (HS) and V3 modes

## 6.2 Bluetooth

The device supports the following *Bluetooth* features:

- *Bluetooth* 4.0 as well as CSA2
- Concurrent operation and built-in coexisting and prioritization handling of *Bluetooth*, BLE, audio processing, and WLAN
- Dedicated audio processor supporting on-chip SBC encoding + A2DP
  - Assisted A2DP (A3DP): SBC encoding implemented internally
  - Assisted WB-speech (AWBS): modified SBC codec implemented internally

### 6.3 BLE

The device supports the following BLE features:

- Bluetooth 4.0 BLE dual-mode standard
- All roles and role combinations, mandatory as well as optional
- Up to 10 BLE connections
- Independent LE buffering allowing many multiple connections with no affect on BR-EDR performance

### 6.4 WiLink 8 Module Markings

Figure 6-2 shows the markings for the TI WiLink 8 module.

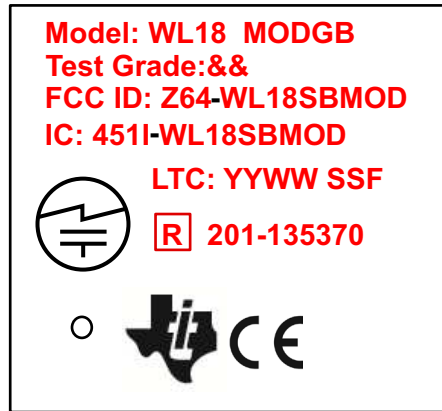



Figure 6-2. WiLink 8 Module Markings

Table 6-4 describes the WiLink 8 module markings.

Table 6-4. Description of WiLink 8 Module Markings

MARKING	DESCRIPTION
WL18 MODGB	Model
&&	Test grade (for more information, see <a href="#">Section 6.5</a> , <i>Test Grades</i> )
Z64-WL18SBMOD	FCC ID: single modular FCC grant ID
451I-WL18SBMOD	IC: single modular IC grant ID
YYWWSSF	LTC (lot trace code): <ul style="list-style-type: none"> <li>• YY = year (for example, 12 = 2012)</li> <li>• WW = week</li> <li>• SS = serial number (01 to 99) matching manufacturer lot number</li> <li>• F = Reserved for internal use</li> </ul>
201-135370	R: single modular TELEC grant ID
	TELEC compliance mark
CE	CE compliance mark

## 6.5 Test Grades

To minimize delivery time, TI may ship the device ordered or an equivalent device currently available that contains at least the functions of the part ordered. From all aspects, this device will behave exactly the same as the part ordered. For example, if a customer orders device WL1801MOD, the part shipped can be marked with a test grade of 37, 07 (see [Table 6-5](#)).

**Table 6-5. Test Grade Markings**

<b>MARK 1</b>	<b>WLAN</b>	<b>BLUETOOTH</b>
0&	Tested	–
3&	Tested	Tested
<b>MARK 2</b>	<b>WLAN 2.4 GHz</b>	<b>MIMO 2.4 GHz</b>
&1	Tested	–
&5	Tested	Tested

## 7 Applications and Implementation

### 7.1 Application Information

#### 7.1.1 Typical Application – WL1835MOD Reference Design

Figure 7-1 shows the TI WL1835MOD reference design.

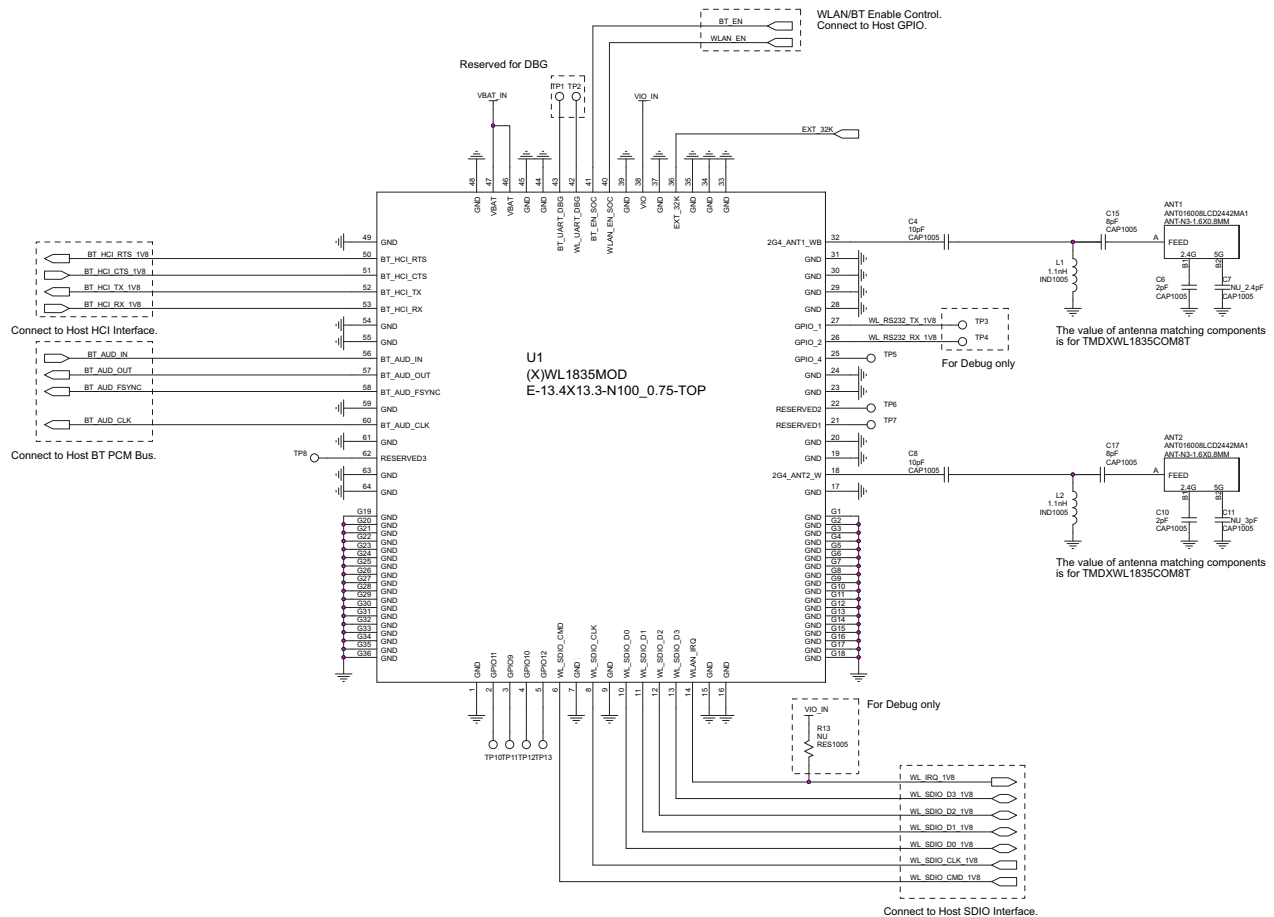

Figure 7-1. TI Module Reference Schematics

Table 7-1 lists the bill materials (BOM).

Table 7-1. Bill of Materials

DESCRIPTION	PART NUMBER	PACKAGE	REFERENCE	QTY	MFR
TI WL 1835 WiFi/BT Module	(X)WL1835MOD	13.4 x 13.3 x 2.0mm	U1	1	TI
ANT/Chip/2.4, 5 GHz/Peak Gain > 5 dBi	ANTO16008LCD2442MA1	1.6 mm x 0.8 mm	ANT1, ANT2	2	TDK
IND 0402/1.2 nH/±0.3/0.12 Ω/300 mA	HI1005-1C1N2SMT	0402	L1, L2	2	ACX
CAP 0402/2.0 pF/50 V/C0G/±0.25 pF	C1005C0G1H020C	0402	C8, C10	2	Walsin
CAP 0402/8.2 pF/50 V/NPO/±0.5 pF	0402N8R2D500	0402	C15, C17	2	Walsin
CAP 0402/10 pF/50 V/NPO/±5%	0402N100J500LT	0402	C4, C6	2	Walsin
RES 0402/10K/±5% (debug only)	WR04X103 JTL	0402	R13	1	Walsin

### 7.1.2 Design Recommendations

This section describes the layout recommendations for the (X)WL1835 module, RF trace, and antenna.

[Table 7-2](#) summarizes the layout recommendations.

**Table 7-2. Layout Recommendations Summary**

ITEM	DESCRIPTION
	<b>Thermal</b>
1	The proximity of ground vias must be close to the pad.
2	Signal traces must not be run underneath the module on the layer where the module is mounted.
3	Have a complete ground pour in layer 2 for thermal dissipation.
4	Have a solid ground plane and ground vias under the module for stable system and thermal dissipation.
5	Increase the ground pour in the first layer and have all of the traces from the first layer on the inner layers, if possible.
6	Signal traces can be run on a third layer under the solid ground layer, which is below the module mounting layer.
	<b>RF Trace and Antenna Routing</b>
7	The RF trace antenna feed must be as short as possible beyond the ground reference. At this point, the trace starts to radiate.
8	The RF trace bends must be gradual with an approximate maximum bend of 45 degrees with trace mitered. RF traces must not have sharp corners.
9	RF traces must have via stitching on the ground plane beside the RF trace on both sides.
10	RF traces must have constant impedance (microstrip transmission line).
11	For best results, the RF trace ground layer must be the ground layer immediately below the RF trace. The ground layer must be solid.
12	There must be no traces or ground under the antenna section.
13	RF traces must be as short as possible. The antenna, RF traces, and modules must be on the edge of the PCB product. The proximity of the antenna to the enclosure and the enclosure material must also be considered.
	<b>Supply and IF</b>
14	The power trace for VBAT must be at least 40-mil wide.
15	The 1.8-V trace must be at least 18-mil wide.
16	Make VBAT traces as wide as possible to ensure reduced inductance and trace resistance.
17	If possible, shield VBAT traces with ground above, below, and beside the traces.
18	SDIO signals traces (CLK, CMD, D0, D1, D2, and D3) must be routed in parallel to each other and as short as possible (less than 12 cm). In addition, every trace length must be the same as the others. There should be enough space between traces – greater than 1.5 times the trace width or ground – to ensure signal quality, especially for the SDIO_CLK trace. Remember to keep these traces away from the other digital or analog signal traces. TI recommends adding ground shielding around these buses.
19	SDIO and digital clock signals are a source of noise. Keep the traces of these signals as short as possible. If possible, maintain a clearance around them.

### 7.1.3 RF Trace and Antenna Layout Recommendations

[Figure 7-2](#) shows the location of the antenna on the WL1835MODCOM8 board as well as the RF trace routing from the (X)WL1835 module (TI reference design). The TDK chip multilayer antennas are mounted on the board with a specific layout and matching circuit for the radiation test conducted in FCC, CE, and IC certifications.

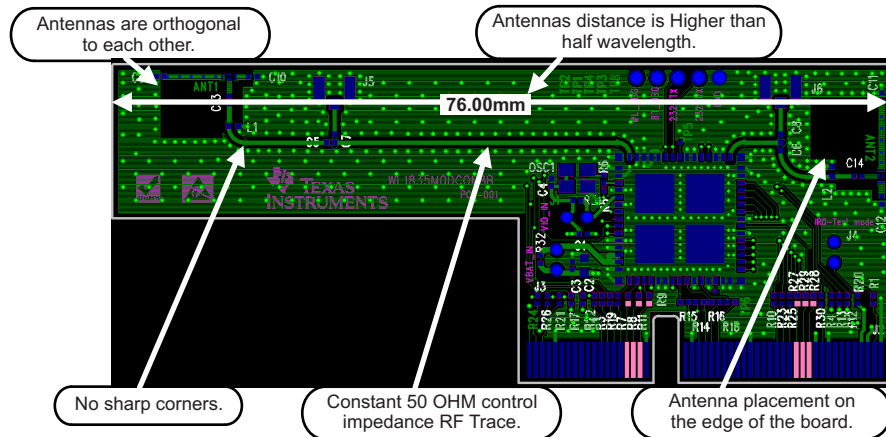

**Figure 7-2. Location of Antenna and RF Trace Routing on the TMDXWL1835MODCOM8T Board**

Follow these RF trace routing recommendations:

- RF traces must have 50-Ω impedance.
- RF traces must not have sharp corners.
- RF traces must have via stitching on the ground plane beside the RF trace on both sides.
- RF traces must be as short as possible. The antenna, RF traces, and module must be on the edge of the PCB product in consideration of the product enclosure material and proximity.

### 7.1.4 Module Layout Recommendations

Figure 7-3 shows layer 1 and layer 2 of the TI module layout:

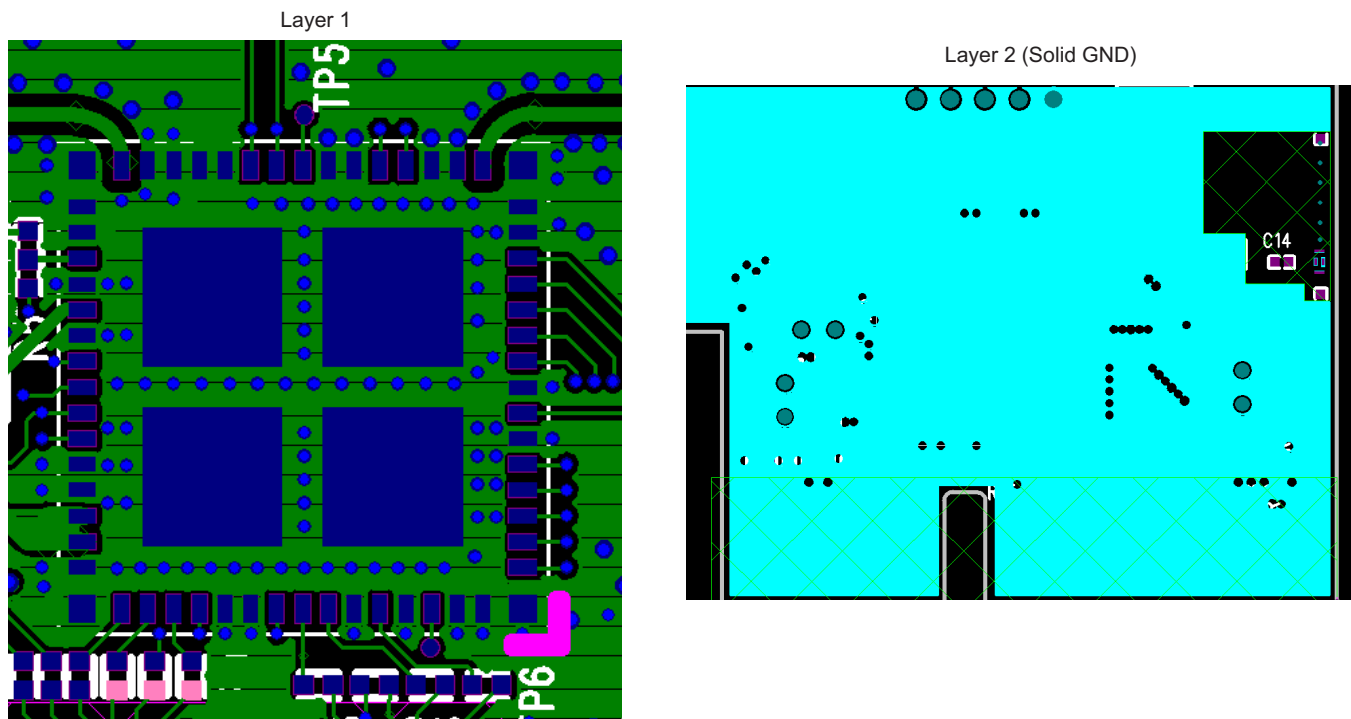

**Figure 7-3. TI Module Layout**

Follow these module layout recommendations:

- Ensure a solid ground plane and ground vias under the module for stable system and thermal dissipation.



- Do not run signal traces underneath the module on a layer where the module is mounted.
- Signal traces can be run on a third layer under the solid ground layer and beneath the module mounting.
- Run the host interfaces with ground on the adjacent layer to improve the return path.
- TI recommends routing the signals as short as possible to the host.

### 7.1.5 Thermal Board Recommendations

The TI module uses  $\mu$ vias for layers 1 through 6 with full copper filling, providing heat flow all the way to the module ground pads.

TI recommends using one big ground pad under the module with vias all the way to connect the pad to all ground layers (see [Figure 7-4](#)).

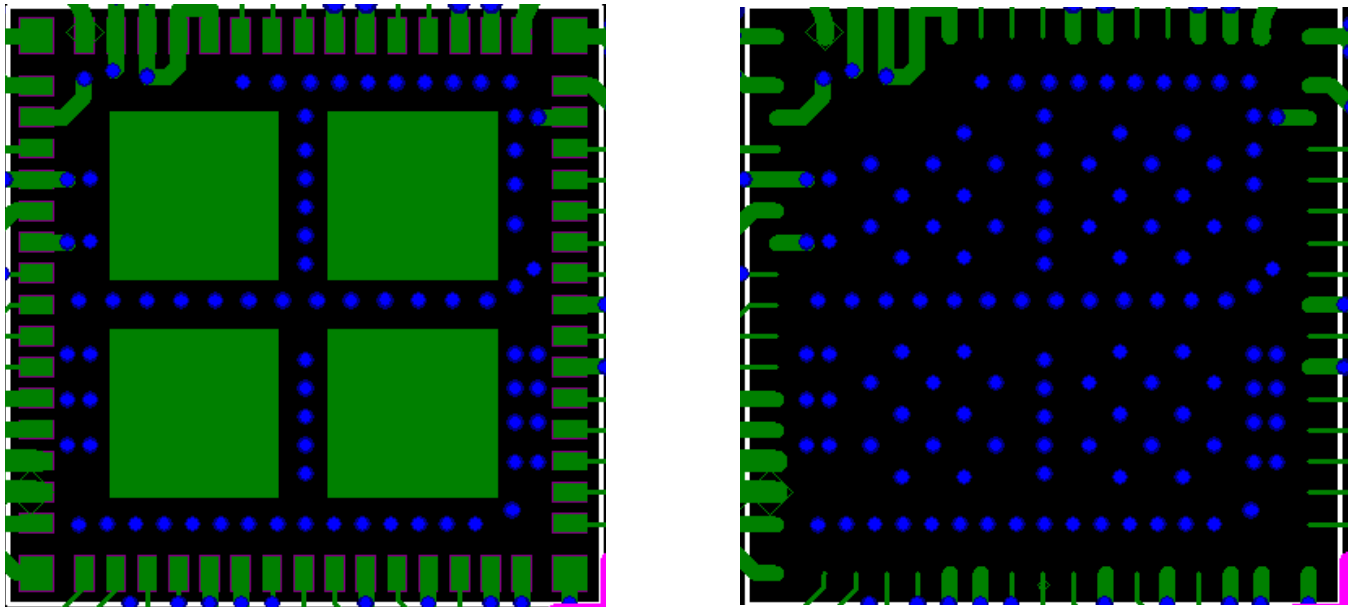
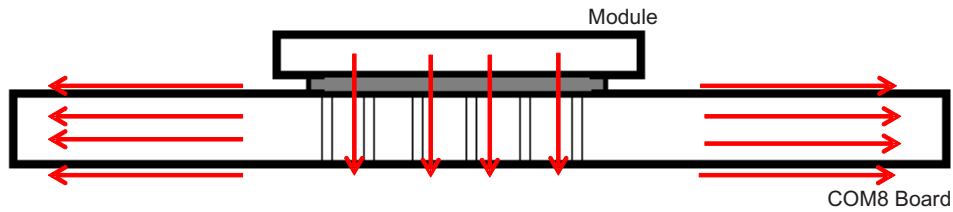

Figure 7-4. Block of Ground Pads on Bottom Side of Package

[Figure 7-5](#) shows via array patterns, which are applied wherever possible to connect all of the layers to the TI module central or main ground pads.



Figure 7-5. Via Array Patterns

## 7.1.6 Baking and SMT Recommendations

### 7.1.6.1 Baking Recommendations

Follow these baking guidelines for the WiLink 8 module:

- Follow MSL level 3 to perform the baking process.
- After the bag is open, devices subjected to reflow solder or other high temperature processes must be mounted within 168 hours of factory conditions (< 30°C/60% RH) or stored at <10% RH.
- if the Humidity Indicator Card reads >10%, devices require baking before being mounted.
- If baking is required, bake devices for 8 hours at 125 °C.

### 7.1.6.2 SMT Recommendations

Figure 7-6 shows the recommended reflow profile for the WiLink 8 module.

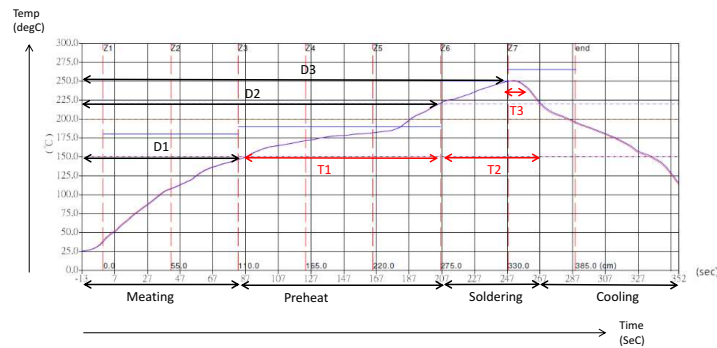

Figure 7-6. Reflow Profile for the WiLink 8 Module

Table 7-3 lists the temperature values for the profile shown in Figure 7-6.

Table 7-3. Temperature Values for Reflow Profile

ITEM	TEMPERATURE (°C)	TIME (s)
Preheat	D1 to approximately D2: 140 to 200	T1: 80 to approximately 120
Soldering	D2: 220	T2: 60 ±10
Peak temperature	D3: 250 max	T3: 10

## 8 Device and Documentation Support

### 8.1 Device Support

#### 8.1.1 Development Support

For a complete listing of development-support tools, visit the Texas Instruments [WL18xx Wiki](#). For information on pricing and availability, contact the nearest TI field sales office or authorized distributor.

#### 8.1.2 Device Support Nomenclature

To designate the stages in the product development cycle, TI assigns prefixes to the part numbers. These prefixes represent evolutionary stages of product development from engineering prototypes through fully qualified production devices.

- X Experimental, preproduction, sample or prototype device. Device may not meet all product qualification conditions and may not fully comply with TI specifications. Experimental/Prototype devices are shipped against the following disclaimer: "This product is still in development and is intended for internal evaluation purposes." Notwithstanding any provision to the contrary, TI makes no warranty expressed, implied, or statutory, including any implied warranty of merchantability of fitness for a specific purpose, of this device.
- null Device is qualified and released to production. TI's standard warranty applies to production devices.

### 8.2 Related Links

The table below lists quick access links. Categories include technical documents, support and community resources, tools and software, and quick access to sample or buy.

表 8-1. Related Links

PARTS	PRODUCT FOLDER	SAMPLE & BUY	TECHNICAL DOCUMENTS	TOOLS & SOFTWARE	SUPPORT & COMMUNITY
WL1801MOD	<a href="#">Click here</a>	<a href="#">Click here</a>	<a href="#">Click here</a>	<a href="#">Click here</a>	<a href="#">Click here</a>
WL1805MOD	<a href="#">Click here</a>	<a href="#">Click here</a>	<a href="#">Click here</a>	<a href="#">Click here</a>	<a href="#">Click here</a>
WL1831MOD	<a href="#">Click here</a>	<a href="#">Click here</a>	<a href="#">Click here</a>	<a href="#">Click here</a>	<a href="#">Click here</a>
WL1835MOD	<a href="#">Click here</a>	<a href="#">Click here</a>	<a href="#">Click here</a>	<a href="#">Click here</a>	<a href="#">Click here</a>

### 8.3 社区资源

下列链接提供到 TI 社区资源的连接。链接的内容由各个分销商“按照原样”提供。这些内容并不构成 TI 技术规范 and 标准且不一定反映 TI 的观点；请见 TI 的[使用条款](#)。

**TI E2E™ 在线社区** *TI 工程师对工程师 (E2E) 社区*。此社区的创建目的是为了促进工程师之间协作。在 [e2e.ti.com](http://e2e.ti.com) 中，您可以咨询问题、共享知识、探索思路，在同领域工程师的帮助下解决问题。

**德州仪器 (TI) 嵌入式处理器维基网站** *德州仪器 (TI) 嵌入式处理器维基网站*。此网站的建立是为了帮助开发人员从德州仪器 (TI) 的嵌入式处理器入门并且也为了促进与这些器件相关的硬件和软件的总体知识的创新和增长。

### 8.4 商标

WiLink, E2E are trademarks of Texas Instruments.  
 ARM is a registered trademark of ARM Physical IP, Inc.  
*Bluetooth* is a registered trademark of Bluetooth SIG, Inc..  
 Android is a trademark of Google Inc.  
 IEEE Std 802.11 is a trademark of IEEE.  
 Linux is a registered trademark of Linus Torvalds.  
 Wi-Fi is a registered trademark of Wi-Fi Alliance.  
 All other trademarks are the property of their respective owners.

## 8.5 静电放电警告



ESD 可能会损坏该集成电路。德州仪器 (TI) 建议通过适当的预防措施处理所有集成电路。如果不遵守正确的处理措施和安装程序，可能会损坏集成电路。

ESD 的损坏小至导致微小的性能降级，大至整个器件故障。精密的集成电路可能更容易受到损坏，这是因为非常细微的参数更改都可能会导致器件与其发布的规格不相符。

## 8.6 术语表

[SLYZ022](#) — TI 术语表。

这份术语表列出并解释术语、首字母缩略词和定义。

## 9 Mechanical Packaging and Orderable Information

### 9.1 TI Module Mechanical Outline

图 9-1 shows the mechanical outline for the device.



图 9-1. TI Module Mechanical Outline

表 9-1 lists the dimensions for the mechanical outline of the device.

表 9-1. Dimensions for TI Module Mechanical Outline

MARKING	MIN (mm)	NOM (mm)	MAX (mm)	MARKING	MIN (mm)	NOM (mm)	MAX (mm)
L (body size)	13.20	13.30	13.40	c2	0.65	0.75	0.85
W (body size)	13.30	13.40	13.50	c3	1.15	1.25	1.35
T (thickness)	1.90		2.00	d1	0.90	1.00	1.10
a1	0.30	0.40	0.50	d2	0.90	1.00	1.10
a2	0.60	0.70	0.80	e1	1.30	1.40	1.50
a3	0.65	0.75	0.85	e2	1.30	1.40	1.50
b1	0.20	0.30	0.40	e3	1.15	1.25	1.35
b2	0.65	0.75	0.85	e4	1.20	1.30	1.40
b3	1.20	1.30	1.40	e5	1.00	1.10	1.20
c1	0.20	0.30	0.40	e6	1.00	1.10	1.20

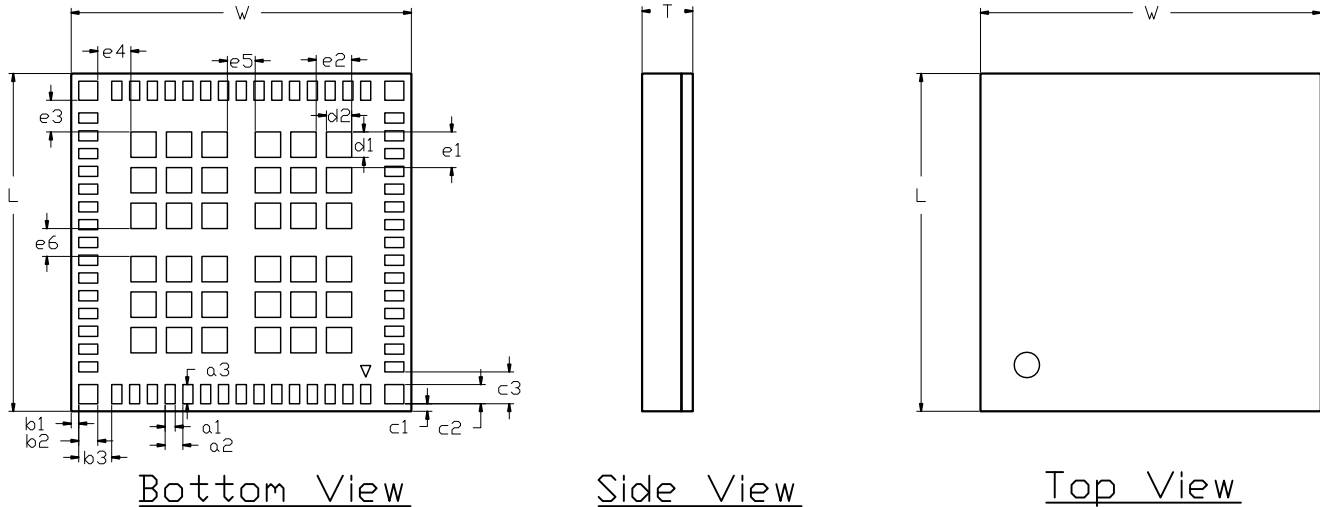
## 9.2 Packaging Information

The following pages include mechanical packaging and orderable information. This information is the most current data available for the designated devices. This data is subject to change without notice and revision of this document. For browser-based versions of this data sheet, refer to the left-hand navigation.

## 重要声明

德州仪器(TI)及其下属子公司有权根据 JESD46 最新标准,对所提供的产品和服务进行更正、修改、增强、改进或其它更改,并有权根据 JESD48 最新标准中止提供任何产品和服务。客户在下订单前应获取最新的相关信息,并验证这些信息是否完整且是最新的。所有产品的销售都遵循在订单确认时所提供的TI 销售条款与条件。

TI 保证其所销售的组件的性能符合产品销售时 TI 半导体产品销售条件与条款的适用规范。仅在 TI 保证的范围内,且 TI 认为有必要时才会使用测试或其它质量控制技术。除非适用法律做出了硬性规定,否则没有必要对每种组件的所有参数进行测试。

TI 对应用帮助或客户产品设计不承担任何义务。客户应对其使用 TI 组件的产品和应用自行负责。为尽量减小与客户产品和应用相关的风险,客户应提供充分的设计与操作安全措施。

TI 不对任何 TI 专利权、版权、屏蔽作品权或其它与使用了 TI 组件或服务的组合设备、机器或流程相关的 TI 知识产权中授予的直接或隐含权限作出任何保证或解释。TI 所发布的与第三方产品或服务有关的信息,不能构成从 TI 获得使用这些产品或服务的许可、授权、或认可。使用此类信息可能需要获得第三方的专利权或其它知识产权方面的许可,或是 TI 的专利权或其它知识产权方面的许可。

对于 TI 的产品手册或数据表中 TI 信息的重要部分,仅在没有对内容进行任何篡改且带有相关授权、条件、限制和声明的情况下才允许进行复制。TI 对此类篡改过的文件不承担任何责任或义务。复制第三方的信息可能需要服从额外的限制条件。

在转售 TI 组件或服务时,如果对该组件或服务参数的陈述与 TI 标明的参数相比存在差异或虚假成分,则会失去相关 TI 组件或服务的所有明示或暗示授权,且这是不正当的、欺诈性商业行为。TI 对任何此类虚假陈述均不承担任何责任或义务。

客户认可并同意,尽管任何应用相关信息或支持仍可能由 TI 提供,但他们将独力负责满足与其产品及其应用中使用的 TI 产品相关的所有法律、法规和安全相关要求。客户声明并同意,他们具备制定与实施安全措施所需的全部专业技术和知识,可预见故障的危险后果、监测故障及其后果、降低有可能造成人身伤害的故障的发生机率并采取适当的补救措施。客户将全额赔偿因在此类安全关键应用中使用任何 TI 组件而对 TI 及其代理造成的任何损失。

在某些场合中,为了推进安全相关应用有可能对 TI 组件进行特别的促销。TI 的目标是利用此类组件帮助客户设计和创立其特有的可满足适用的功能安全性标准和要求的终端产品解决方案。尽管如此,此类组件仍然服从这些条款。

TI 组件未获得用于 FDA Class III (或类似的生命攸关医疗设备)的授权许可,除非各方授权官员已经达成了专门管控此类使用的特别协议。

只有那些 TI 特别注明属于军用等级或“增强型塑料”的 TI 组件才是设计或专门用于军事/航空应用或环境的。购买者认可并同意,对并非指定面向军事或航空航天用途的 TI 组件进行军事或航空航天方面的应用,其风险由客户单独承担,并且由客户独力负责满足与此类使用相关的所有法律和法规要求。

TI 已明确指定符合 ISO/TS16949 要求的产品,这些产品主要用于汽车。在任何情况下,因使用非指定产品而无法达到 ISO/TS16949 要求, TI 不承担任何责任。

	产品		应用
数字音频	<a href="http://www.ti.com.cn/audio">www.ti.com.cn/audio</a>	通信与电信	<a href="http://www.ti.com.cn/telecom">www.ti.com.cn/telecom</a>
放大器和线性器件	<a href="http://www.ti.com.cn/amplifiers">www.ti.com.cn/amplifiers</a>	计算机及周边	<a href="http://www.ti.com.cn/computer">www.ti.com.cn/computer</a>
数据转换器	<a href="http://www.ti.com.cn/dataconverters">www.ti.com.cn/dataconverters</a>	消费电子	<a href="http://www.ti.com.cn/consumer-apps">www.ti.com.cn/consumer-apps</a>
DLP® 产品	<a href="http://www.dlp.com">www.dlp.com</a>	能源	<a href="http://www.ti.com.cn/energy">www.ti.com.cn/energy</a>
DSP - 数字信号处理器	<a href="http://www.ti.com.cn/dsp">www.ti.com.cn/dsp</a>	工业应用	<a href="http://www.ti.com.cn/industrial">www.ti.com.cn/industrial</a>
时钟和计时器	<a href="http://www.ti.com.cn/clockandtimers">www.ti.com.cn/clockandtimers</a>	医疗电子	<a href="http://www.ti.com.cn/medical">www.ti.com.cn/medical</a>
接口	<a href="http://www.ti.com.cn/interface">www.ti.com.cn/interface</a>	安防应用	<a href="http://www.ti.com.cn/security">www.ti.com.cn/security</a>
逻辑	<a href="http://www.ti.com.cn/logic">www.ti.com.cn/logic</a>	汽车电子	<a href="http://www.ti.com.cn/automotive">www.ti.com.cn/automotive</a>
电源管理	<a href="http://www.ti.com.cn/power">www.ti.com.cn/power</a>	视频和影像	<a href="http://www.ti.com.cn/video">www.ti.com.cn/video</a>
微控制器 (MCU)	<a href="http://www.ti.com.cn/microcontrollers">www.ti.com.cn/microcontrollers</a>		
RFID 系统	<a href="http://www.ti.com.cn/rfidsys">www.ti.com.cn/rfidsys</a>		
OMAP应用处理器	<a href="http://www.ti.com.cn/omap">www.ti.com.cn/omap</a>		
无线连通性	<a href="http://www.ti.com.cn/wirelessconnectivity">www.ti.com.cn/wirelessconnectivity</a>	德州仪器在线技术支持社区	<a href="http://www.deyisupport.com">www.deyisupport.com</a>

邮寄地址: 上海市浦东新区世纪大道1568号, 中建大厦32楼邮政编码: 200122  
Copyright © 2014, 德州仪器半导体技术(上海)有限公司

**PACKAGING INFORMATION**

Orderable Device	Status (1)	Package Type	Package Drawing	Pins	Package Qty	Eco Plan (2)	Lead/Ball Finish (6)	MSL Peak Temp (3)	Op Temp (°C)	Device Marking (4/5)	Samples
WL1801MODGBMOCR	ACTIVE	QFM	MOC	100	1200	Green (RoHS & no Sb/Br)	Call TI	Level-3-260C-168 HR	-20 to 70	WL18MODGB 01 Z64-WL18SBMOD 451I-WL18SBMOD 201-135370	<a href="#">Samples</a>
WL1801MODGBMOCT	ACTIVE	QFM	MOC	100	250	Green (RoHS & no Sb/Br)	Call TI	Level-3-260C-168 HR	-20 to 70	WL18MODGB 01 Z64-WL18SBMOD 451I-WL18SBMOD 201-135370	<a href="#">Samples</a>
WL1805MODGBMOCR	ACTIVE	QFM	MOC	100	1200	Green (RoHS & no Sb/Br)	Call TI	Level-3-260C-168 HR	-20 to 70	WL18MODGB 05 Z64-WL18SBMOD 451I-WL18SBMOD 201-135370	<a href="#">Samples</a>
WL1805MODGBMOCT	ACTIVE	QFM	MOC	100	250	Green (RoHS & no Sb/Br)	Call TI	Level-3-260C-168 HR	-20 to 70	WL18MODGB 05 Z64-WL18SBMOD 451I-WL18SBMOD 201-135370	<a href="#">Samples</a>
WL1831MODGBMOCR	ACTIVE	QFM	MOC	100	1200	Green (RoHS & no Sb/Br)	Call TI	Level-3-260C-168 HR	-20 to 70	WL18MODGB 31 Z64-WL18SBMOD 451I-WL18SBMOD 201-135370	<a href="#">Samples</a>
WL1831MODGBMOCT	ACTIVE	QFM	MOC	100	250	Green (RoHS & no Sb/Br)	Call TI	Level-3-260C-168 HR	-20 to 70	WL18MODGB 31 Z64-WL18SBMOD 451I-WL18SBMOD 201-135370	<a href="#">Samples</a>
WL1835MODGBMOCR	ACTIVE	QFM	MOC	100	1200	Green (RoHS & no Sb/Br)	Call TI	Level-3-260C-168 HR	-20 to 70	WL18MODGB 35 Z64-WL18SBMOD 451I-WL18SBMOD 201-135370	<a href="#">Samples</a>
WL1835MODGBMOCT	ACTIVE	QFM	MOC	100	250	Green (RoHS & no Sb/Br)	Call TI	Level-3-260C-168 HR	-20 to 70	WL18MODGB 35 Z64-WL18SBMOD	<a href="#">Samples</a>



Orderable Device	Status (1)	Package Type	Package Drawing	Pins	Package Qty	Eco Plan (2)	Lead/Ball Finish (6)	MSL Peak Temp (3)	Op Temp (°C)	Device Marking (4/5)	Samples
										451I-WL18SBMOD 201-135370	

(1) The marketing status values are defined as follows:

**ACTIVE:** Product device recommended for new designs.

**LIFEBUY:** TI has announced that the device will be discontinued, and a lifetime-buy period is in effect.

**NRND:** Not recommended for new designs. Device is in production to support existing customers, but TI does not recommend using this part in a new design.

**PREVIEW:** Device has been announced but is not in production. Samples may or may not be available.

**OBSELETE:** TI has discontinued the production of the device.

(2) **RoHS:** TI defines "RoHS" to mean semiconductor products that are compliant with the current EU RoHS requirements for all 10 RoHS substances, including the requirement that RoHS substance do not exceed 0.1% by weight in homogeneous materials. Where designed to be soldered at high temperatures, "RoHS" products are suitable for use in specified lead-free processes. TI may reference these types of products as "Pb-Free".

**RoHS Exempt:** TI defines "RoHS Exempt" to mean products that contain lead but are compliant with EU RoHS pursuant to a specific EU RoHS exemption.

**Green:** TI defines "Green" to mean the content of Chlorine (Cl) and Bromine (Br) based flame retardants meet JS709B low halogen requirements of <=1000ppm threshold. Antimony trioxide based flame retardants must also meet the <=1000ppm threshold requirement.

(3) MSL, Peak Temp. - The Moisture Sensitivity Level rating according to the JEDEC industry standard classifications, and peak solder temperature.

(4) There may be additional marking, which relates to the logo, the lot trace code information, or the environmental category on the device.

(5) Multiple Device Markings will be inside parentheses. Only one Device Marking contained in parentheses and separated by a "~" will appear on a device. If a line is indented then it is a continuation of the previous line and the two combined represent the entire Device Marking for that device.

(6) Lead/Ball Finish - Orderable Devices may have multiple material finish options. Finish options are separated by a vertical ruled line. Lead/Ball Finish values may wrap to two lines if the finish value exceeds the maximum column width.

**Important Information and Disclaimer:**The information provided on this page represents TI's knowledge and belief as of the date that it is provided. TI bases its knowledge and belief on information provided by third parties, and makes no representation or warranty as to the accuracy of such information. Efforts are underway to better integrate information from third parties. TI has taken and continues to take reasonable steps to provide representative and accurate information but may not have conducted destructive testing or chemical analysis on incoming materials and chemicals. TI and TI suppliers consider certain information to be proprietary, and thus CAS numbers and other limited information may not be available for release.

In no event shall TI's liability arising out of such information exceed the total purchase price of the TI part(s) at issue in this document sold by TI to Customer on an annual basis.

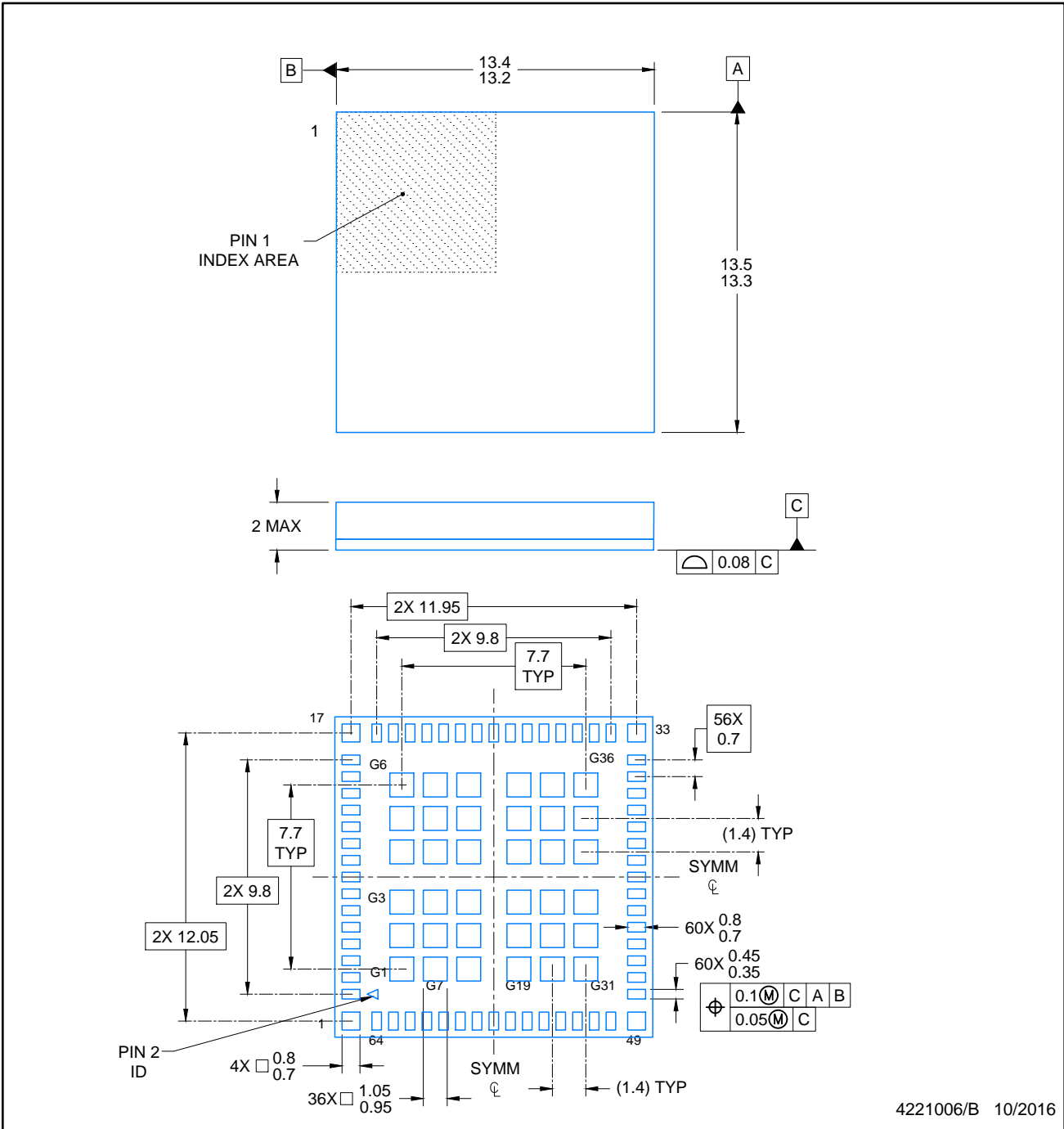

4221006/B 10/2016

NOTES:

1. All linear dimensions are in millimeters. Any dimensions in parenthesis are for reference only. Dimensioning and tolerancing per ASME Y14.5M.
2. This drawing is subject to change without notice.
3. The package thermal pads must be soldered to the printed circuit board for thermal and mechanical performance.

# EXAMPLE BOARD LAYOUT

QFM - 2.0 mm max height

MOC0100A

QUAD FLAT MODULE

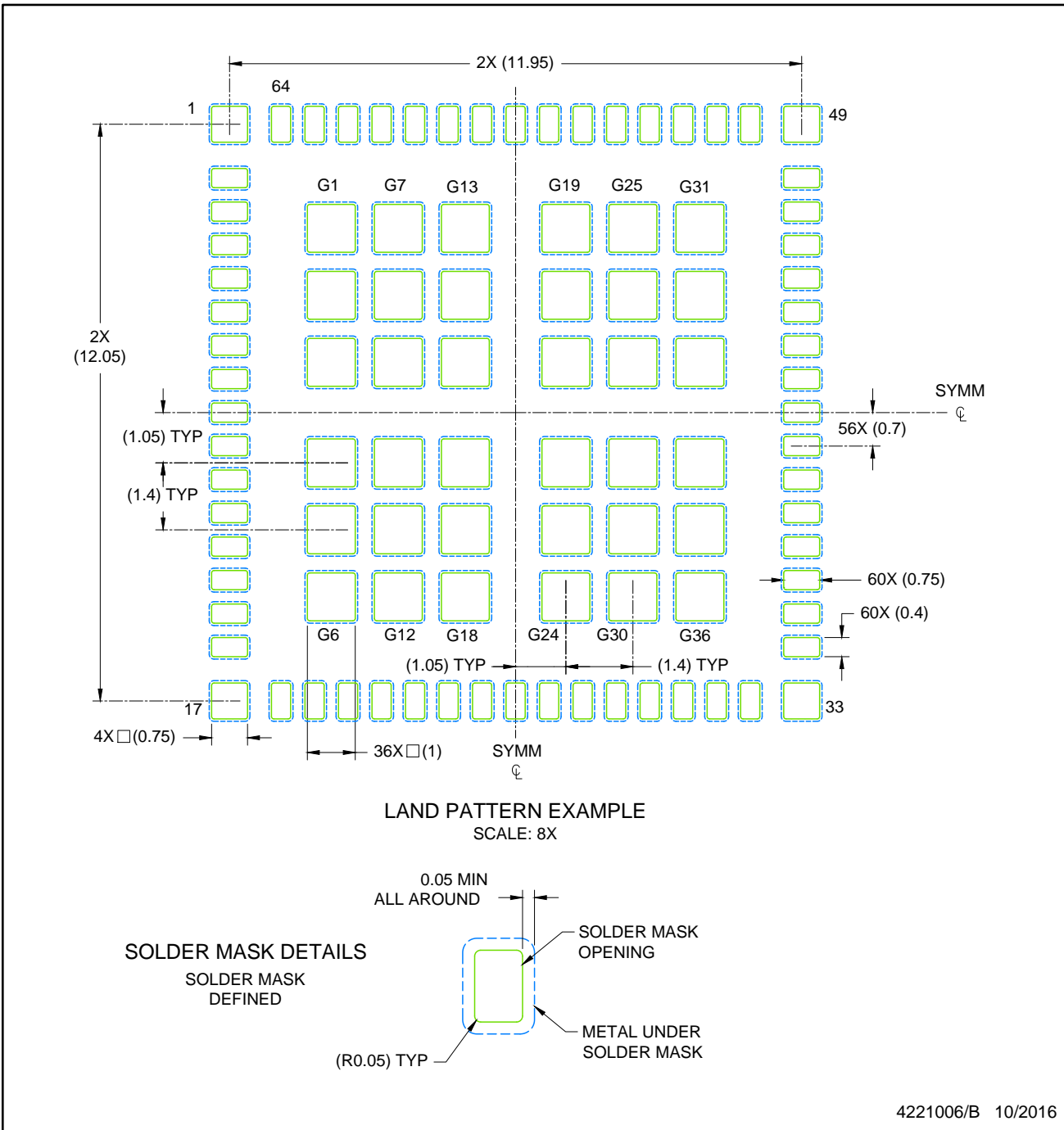

NOTES: (continued)

4. This package is designed to be soldered to thermal pads on the board. For more information, see Texas Instruments literature number SLUA271 ([www.ti.com/lit/sluea271](http://www.ti.com/lit/sluea271)).
5. Solder mask tolerances between and around signal pads can vary based on board fabrication site.
6. Vias are optional depending on application, refer to device data sheet. If any vias are implemented, it is recommended that vias under paste be filled, plugged or tented.

# EXAMPLE STENCIL DESIGN

QFM - 2.0 mm max height

MOC0100A

QUAD FLAT MODULE

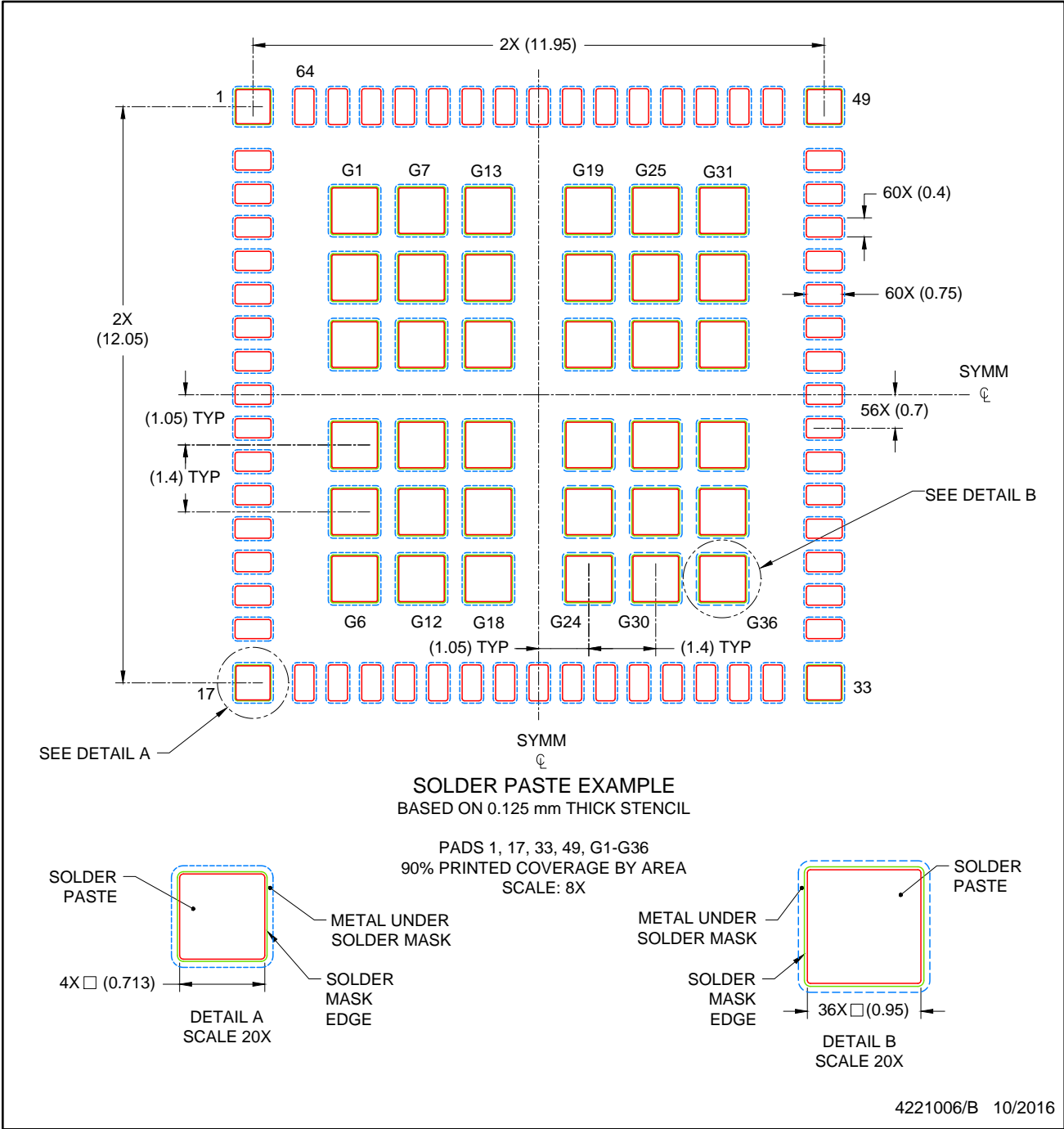

NOTES: (continued)

7. Laser cutting apertures with trapezoidal walls and rounded corners may offer better paste release. IPC-7525 may have alternate design recommendations..

## 重要声明

德州仪器 (TI) 公司有权按照最新发布的 JESD46 对其半导体产品和服务进行纠正、增强、改进和其他修改，并不再按最新发布的 JESD48 提供任何产品和服务。买方在下订单前应获取最新的相关信息，并验证这些信息是否完整且是最新的。

TI 公布的半导体产品销售条款 (<https://www.sunnywale.com>) 适用于 TI 已认证和批准上市的已封装集成电路产品的销售。另有其他条款可能适用于其他类型 TI 产品及服务的使用或销售。

复制 TI 数据表上 TI 信息的重要部分时，不得变更该等信息，且必须随附所有相关保证、条件、限制和通知，否则不得复制。TI 对该等复制文件不承担任何责任。第三方信息可能受到其它限制条件的制约。在转售 TI 产品或服务时，如果存在对产品或服务参数的虚假陈述，则会失去相关 TI 产品或服务的明示或暗示保证，且构成不公平的、欺诈性商业行为。TI 对此类虚假陈述不承担任何责任。

买方和在系统中整合 TI 产品的其他开发人员（总称“设计人员”）理解并同意，设计人员在设计应用时应自行实施独立的分析、评价和判断，且应全权负责并确保应用的安全性，及设计人员的应用（包括应用中使用的 TI 产品）应符合所有适用的法律法规及其他相关要求。设计人员就自己设计的应用声明，其具备制订和实施下列保障措施所需的一切必要专业知识，能够 (1) 预见故障的危险后果，(2) 监视故障及其后果，以及 (3) 降低可能导致危险的故障几率并采取适当措施。设计人员同意，在使用或分发包含 TI 产品的任何应用前，将彻底测试该等应用和该等应用中所用 TI 产品的功能。

TI 提供技术、应用或其他设计建议、质量特点、可靠性数据或其他服务或信息，包括但不限于与评估模块有关的参考设计和材料（总称“TI 资源”），旨在帮助设计人员开发整合了 TI 产品的应用，如果设计人员（个人，或如果是代表公司，则为设计人员的公司）以任何方式下载、访问或使用任何特定的 TI 资源，即表示其同意仅为该等目标，按照本通知的条款使用任何特定 TI 资源。

TI 所提供的 TI 资源，并未扩大或以其他方式修改 TI 对 TI 产品的公开适用的质保及质保免责声明；也未导致 TI 承担任何额外的义务或责任。TI 有权对其 TI 资源进行纠正、增强、改进和其他修改。除特定 TI 资源的公开文档中明确列出的测试外，TI 未进行任何其他测试。

设计人员只有在开发包含该等 TI 资源所列 TI 产品的应用时，才被授权使用、复制和修改任何相关单项 TI 资源。但并未依据禁止反言原则或其他法律授予您任何 TI 知识产权的任何其他明示或默示的许可，也未授予您 TI 或第三方的任何技术或知识产权的许可，该等许可包括但不限于任何专利权、版权、屏蔽作品权或与美国 TI 产品或服务的任何整合、机器制作、流程相关的其他知识产权。涉及或参考了第三方产品或服务的信息不构成使用此类产品或服务的许可或与其相关的保证或认可。使用 TI 资源可能需要您向第三方获得对该等第三方专利或其他知识产权的许可。

TI 资源系“按原样”提供。TI 兹免除对资源及其使用作出所有其他明确或默示的保证或陈述，包括但不限于对准确性或完整性、产权保证、无屡发故障保证，以及适销性、适合特定用途和不侵犯任何第三方知识产权的任何默认保证。TI 不负任何责任，包括但不限于因组合产品所致或与之有关的申索，也不为或对设计人员进行辩护或赔偿，即使该等产品组合已列于 TI 资源或其他地方。对因 TI 资源或其使用引起或与之有关的任何实际的、直接的、特殊的、附带的、间接的、惩罚性的、偶发的、从属或惩戒性损害赔偿，不管 TI 是否获悉可能会产生上述损害赔偿，TI 概不负责。

除 TI 已明确指出特定产品已达到特定行业标准（例如 ISO/TS 16949 和 ISO 26262）的要求外，TI 不对未达到任何该等行业标准要求而承担任何责任。

如果 TI 明确宣称产品有助于功能安全或符合行业功能安全标准，则该等产品旨在帮助客户设计和创作自己的符合相关功能安全标准和要求的的应用。在应用内使用产品的行为本身不会配有安全特性。设计人员必须确保遵守适用于其应用的相关安全要求和标准。设计人员不可将任何 TI 产品用于关乎性命的医疗设备，除非已由各方获得授权的管理人员签署专门的合同对此类应用专门作出规定。关乎性命的医疗设备是指出现故障会导致严重身体伤害或死亡的医疗设备（例如生命保障设备、心脏起搏器、心脏除颤器、人工心脏泵、神经刺激器以及植入设备）。此类设备包括但不限于，美国食品药品监督管理局认定为 III 类设备的设备，以及在美国以外的其他国家或地区认定为同等类别设备的所有医疗设备。

TI 可能明确指定某些产品具备某些特定资格（例如 Q100、军用级或增强型产品）。设计人员同意，其具备一切必要专业知识，可以为自己的应用选择适合的产品，并且正确选择产品的风险由设计人员承担。设计人员单方面负责遵守与该等选择有关的所有法律或监管要求。

设计人员同意向 TI 及其代表全额赔偿因其不遵守本通知条款和条件而引起的任何损害、费用、损失和/或责任。

邮寄地址：深圳市宝安区沙井街道沙头社区创新路5号锦驰创新城A区20-203，

邮政编码：518104 Copyright © 2017 德州仪器半导体技术（深圳代理处）有限公司

Sales: Shenzhen Sunnywale Inc, [www.sunnywale.com](http://www.sunnywale.com), [awin@sunnywale.com](mailto:awin@sunnywale.com), Wechat: 9308762