

A12A35 Chip Datasheet - Preliminary

SUMMARY DESCRIPTION

The A12A35 is an integrated system-on-a-chip (SoC) platform for single- and multi-channel automotive video camera solutions.

A12A35 chips provide a 792-MHz ARM Cortex-A9 CPU and an advanced digital signal processing (DSP) subsystem with a 64-Mpixel image sensor pipeline (ISP) and a high-definition (HD) H.264 codec engine.

KEY FEATURES

- Embedded ARM Cortex-A9 792-MHz CPU
- More than 480 MPixel/s processing rate
 - 64-MPixel maximum resolution
- Fish-eye lens dewarping and barrel distortion correction
- Advanced motion-compensated sharpening
- Advanced dynamic range (WDR and HDR) engine
- H.264 BP/MP/HP Level 5.1 and MJPEG codecs
- Encode performance up to 3Mp30 (in a single-channel configuration) or 1080p30+720p30 (in a dual-channel configuration)
- Two input channels with multiple serial input modes
- 114 General Purpose Input/Output (GPIO) short-height pins
- 404-pin TFBGA package (15 mm x 15 mm)
- 28-nm CMOS Low Power (LP) technology

CONTENTS

1. Overview	1
2. Interfaces	8
3. Pins	19
4. Electrical Characteristics	37
5. Package	52
6. Contact and Order Information.....	54
7. Pin List and Mapping Table.....	55
8. Additional Resources	70
9. Important Notice	71
10. Typographical Conventions.....	72
11. Revision History.....	73

The material in this document is for information only. Ambarella assumes no responsibility for errors or omissions and reserves the right to change, without notice, product specifications, operating characteristics, packaging, ordering, etc. Ambarella assumes no liability for damage resulting from the use of information contained in this document. All brands, product names and company names are trademarks of their respective owners. Further information, including additional disclaimers, appears in the Important Notice at the end of this document.



1. OVERVIEW

This preliminary datasheet for the A12A35 processor from Ambarella begins with a brief introduction to the chip (Section 1.1) and a summary of key features (Section 1.2). Chapter 2 describes the A12A35 peripheral interfaces. For pin details and electrical characteristics refer to Chapter 3 and Chapter 4, respectively. See Chapter 5 for package information and Chapter 6 for Ambarella contact and ordering details.

Please note that the chip features described in this datasheet are subject to change. Details that have not been entirely finalized (e.g., encoding specifics) are provided using conservative estimates (i.e., final encoding performance is expected to meet or exceed the estimate provided). Please contact an Ambarella representative for additional information.

1.1 Introduction

The A12A35 is an integrated system-on-a-chip (SoC) platform for single- and multi-channel automotive video camera solutions. A12A35 chips provide a single-core Cortex-A9 ARM CPU and an advanced digital signal processing (DSP) subsystem with a 64-Mpixel image sensor pipeline (ISP) and a high-definition (HD) H.264 codec engine. A functional block diagram of the A12A35 SoC is provided below.

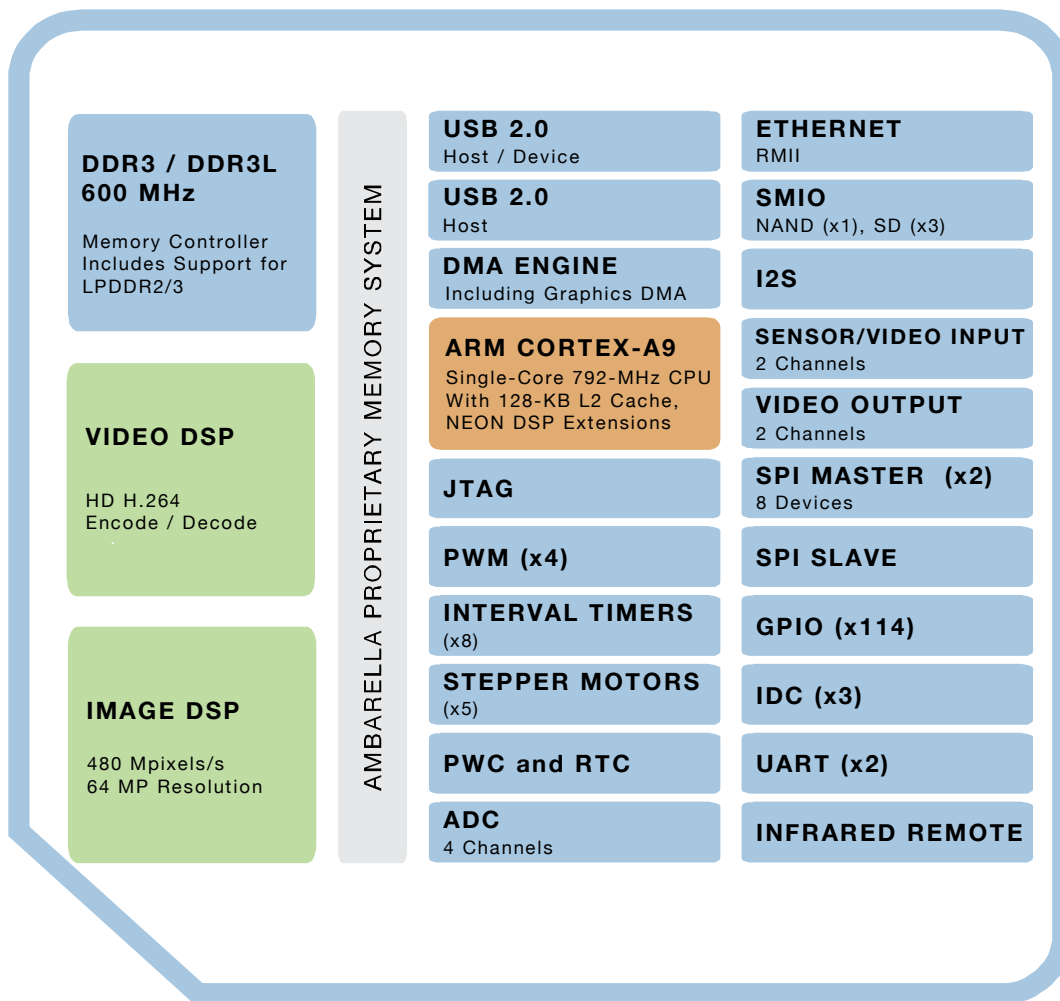

Figure 1-1. A12A35 Overview: Functional Block Diagram of the A12A35 SoC.

The Ambarella A12A35 chip enables the capture of up to 3Mp30-resolution (single-channel) or 1080p30+720p30-resolution (dual-channel) video for automotive applications.

The A12A35 chip can be used in a variety of configurations depending on specific application needs:

- **Single-channel camera systems**
- **Standalone dual-channel camera systems**
 - Two local sensors generate two distinct inputs to the A12A35 SoC ([Figure 1-2](#))

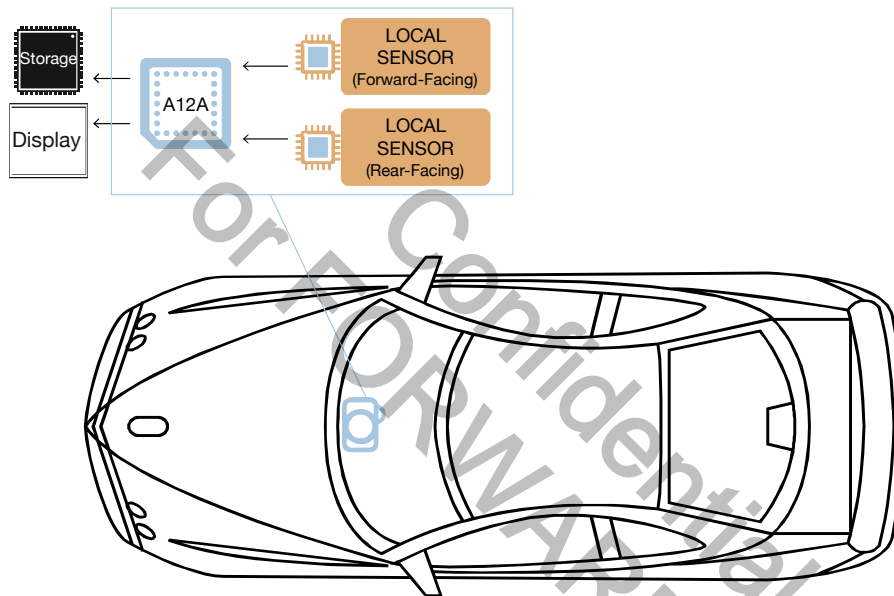

Figure 1-2. A12A35 Automotive Video Camera Application: Two-Channel Standalone with Two Local Sensors.

- **Ambarella B5-equipped camera systems**
 - Two possible configurations:
 1. Two remote sensor inputs are sent to the A12A35 SoC via the Ambarella B5F (serializer) and B5Nd (de-serializer) companion chips ([Figure 1-3](#))
 - Sensor inputs are routed through the Ambarella B5F serializer chip to the B5Nd de-serializer chip via a USB cable (up to 7.5 m) or an HDMI cable (up to 10 m)
 - Note that both sensors must be the same type, and must be configured identically.
 2. Inputs from both a local sensor and a remote sensor are sent to the A12A35 SoC ([Figure 1-4](#))
 - The remote sensor input is routed through the Ambarella B5F serializer chip to the B5Nd de-serializer chip via a USB cable (up to 7.5 m) or an HDMI cable (up to 10 m)
 - Note that this configuration allows the use of different sensor types (e.g., HD-capable and Full-HD-capable).

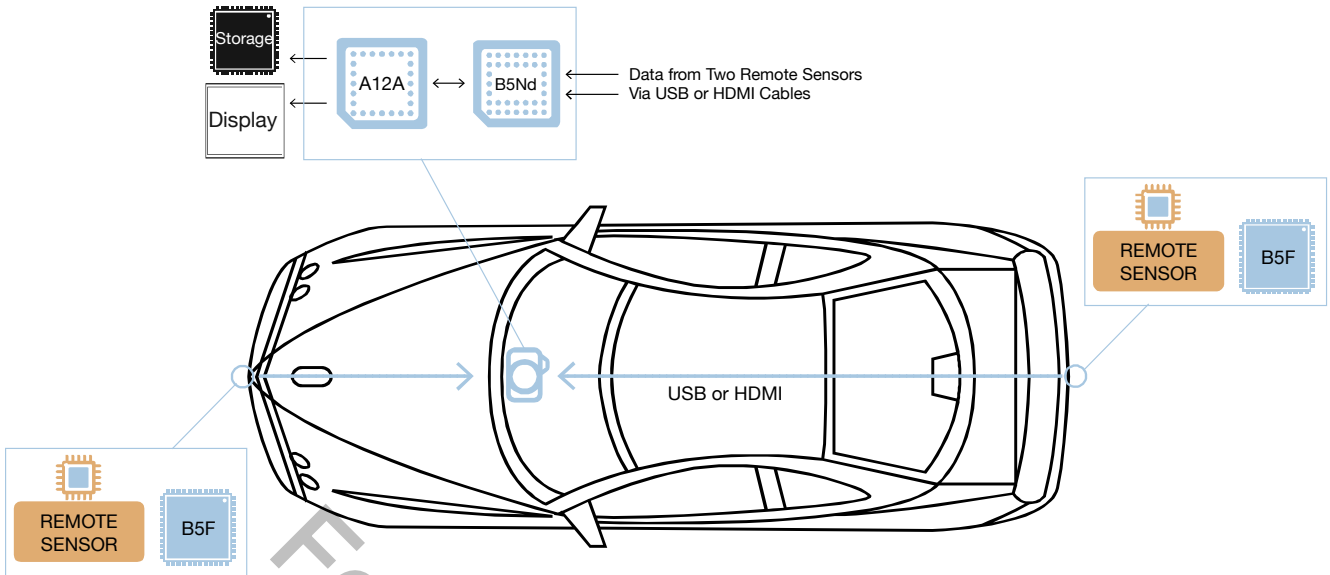

Figure 1-3. A12A35 Automotive Camera Application: Dual Remote Sensor Configuration (B5-Equipped).

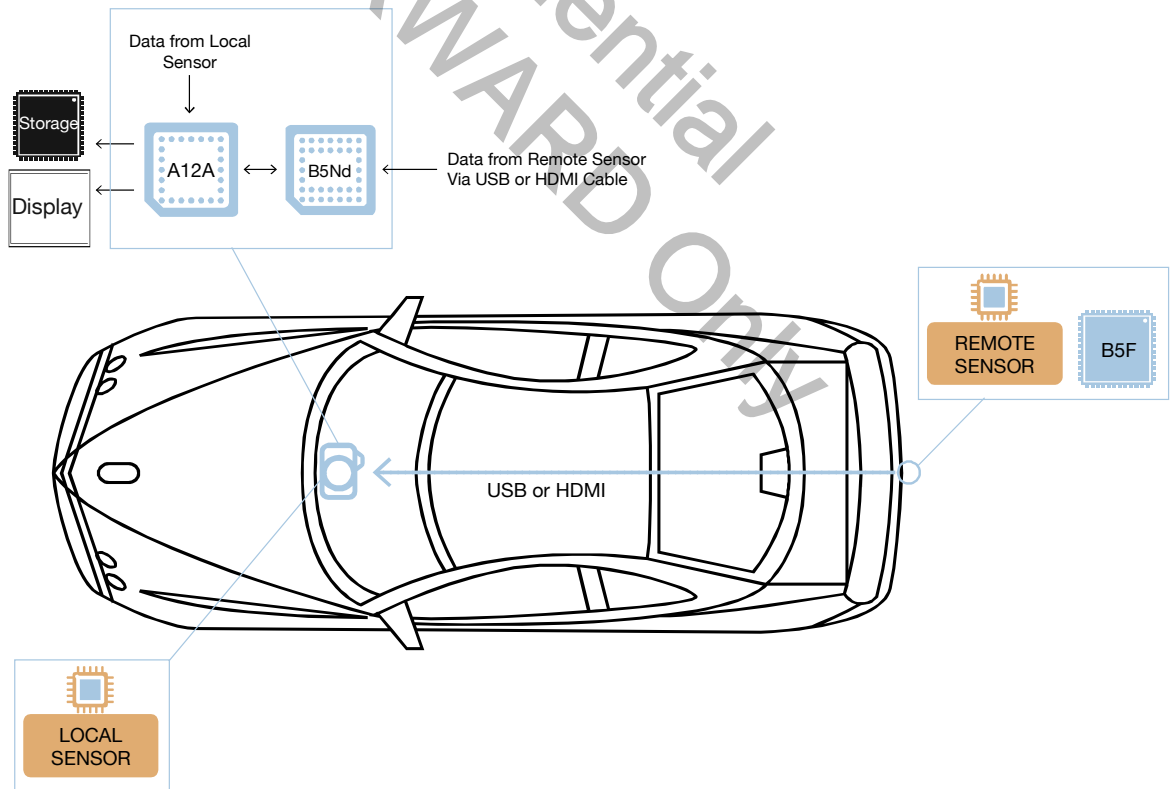

Figure 1-4. A12A35 Automotive Camera Application: Local / Remote Sensor Configuration (B5-Equipped).

The A12A35 SoC provides a glueless interface to Serial Sub-LVDS, HiSPi, and MIPI interfaces, as well as parallel connections to popular CMOS image sensors. The ISP offers advanced image-processing features, including improved high dynamic range (HDR) processing with multi-exposure fusion, wide dynamic range (WDR) local contrast enhancement, 3D motion-compensated noise reduction (MCTF), edge enhancement, 3A, image stabilization, and dewarping.

The H.264 codec engine delivers versatile encoding up to 3Mp30 total performance in a single-channel configuration. The high-efficiency H.264 encoder implements progressive refresh for low-latency operations, as well as advanced Main and High-Profile functions for the highest-quality and lowest possible bitrate. These functions include bidirectional prediction (B-frames), large motion-estimation search range, and macroblock-level quantization. Ambarella builds in flexibility with a multi-streaming function, allowing on-the-fly start/stop as well as the adjustment of the bitrate, frame rate, and GOP of each individual stream. The A12A35 WiFi module supports fast-action capture with loop recording, remote view finders, and remote control by handheld devices.

A 792-MHz ARM Cortex-A9 CPU with NEON DSP extensions and floating point support is available for implementing full-featured user applications.

The A12 family is fabricated using low-power 28-nm CMOS technology and integrates advanced power-saving modes, such as utilizing DSP-subsystem memory resources to reduce external memory bandwidth and total camera system power requirements.

1.2 Feature List

Features of the A12A35 chip include:

- Embedded single-core ARM Cortex-A9 CPU
 - Clock frequency up to 792-MHz
 - 32-KByte data / 32-KByte instruction cache
 - 128-KByte L2 cache
 - NEON SIMD engine
- DDR3 and DDR3L controller
 - Up to 600-MHz clock rate
 - 16-bit wide data bus
 - Maximum capacity of 8 Gbits (1 GByte)
 - Includes support for the LPDDR2 and LPDDR3 low-power DDR interfaces
- Image pipeline
 - More than 480 MPixel/s processing rate
 - 64-MPixel maximum resolution
 - Fish-eye lens dewarping and barrel distortion correction
 - Black level correction
 - Dynamic and static defect pixel cluster correction
 - CFA crosstalk and fixed-pattern noise reduction
 - RGB Bayer demosaicing
 - Lens shading

- 3D LUT color transform with gamma
- Advanced motion-compensated sharpening
- Advanced dynamic range (WDR and HDR) engine with multi-exposure fusion and motion artifact reduction
- Per-pixel local exposure dynamic range enhancement
- Tone mapping and global tone-curve adjustment
- Chromatic aberration correction
- Flexible APIs and image-tuning tools
- Adjustable 3A; exposure, white balance and focus control (AE/AWB/AF)
- Day/Night and DC/P iris control
- Crop, mirror, flip, 90°/270° rotation
- Image stabilization with rolling shutter compensation
- Video engine
 - H.264 BP/MP/HP Level 5.1 and MJPEG codecs
 - Maximum encode performance:
 - 3Mp30 in a single-channel configuration
 - 1080p30+720p30 in a dual-channel configuration
 - 1280x720p60
 - Advanced H.264 compression tools
 - I, IP, IBP modes (M=1,2,3,4...; IP, IBP, IBBP, IBBBP...)
 - High Profile with B-frames and hierarchical GOP
 - Up to three reference frames
 - Flexible rate control
 - CBR, VBR and Constant QP with max bitrate control
 - Macroblock-level adaptive quantization
 - 3D noise reduction (MCTF)
- Sensor/Video Input (VIN) interfaces
 - Two input channels with multiple input modes
 - Primary channel supports up to 8-lane SLVS / HiSPi input and up to 4-lane MIPI input
 - Secondary channel supports up to 2-lane SLVS / HiSPi / MIPI input
 - In SVLS mode the two input channels may be combined to support a single 10-lane SLVS / HiSPi sensor
 - Support for 14-bit parallel and LVCMOS sensors
 - Support for popular CMOS sensors; Aptina, Sony, OV, Panasonic, Samsung
 - Two clocking options (PLL-generated GCLK_VIN or SLVS bit clock)
 - 16-bit CCIR.601 video input with external sync signals
 - 8-bit, 10-bit, 12-bit or 14-bit BT.656 video input with embedded sync codes including full-data-range support

- Video Output (VOUT) interfaces
 - Two logical channels to drive three video output ports
 - One logical channel drives HDMI or analog
 - One logical channel drives digital
 - Popular LCD panel controllers (RGB mode)
 - Support for RGBA and YUVA OSD
 - Video DAC for 480i/576i composite PAL/NTSC output
 - BT.656 embedded sync YUV output (8-bit or 16-bit mode)
 - HDMI 1.4b output with Consumer Electronics Control (CEC) and on-chip PHY
- AHB Bus DMA controller
 - Memory-to-memory transfers including support for transfers between memory and peripherals
 - Programmable transfer count up to 4 MB
 - DMA scatter/gather via chained descriptor list in memory with DMA control information source
- Dedicated DMA co-processor for graphics and image operations
 - Offers linear copy, 2-D copy, composite, and alpha-blend image operations
 - Supports 4- to 32-bit pixel formats
- I2S digital audio interface (stereo)
 - Audio encoding/decoding
- Ethernet MAC controller
 - IEEE 802.3 compliant with full- and half-duplex (IEEE 802.3x flow-control) and Jumbo frames
 - IEEE 802.1Q VLAN tag detection
 - Checksum off-load for received IP and TCP/UDP packets
 - Dedicated pins for RMII or MII interface
 - FIFO (2 KB / 2 KB) and DMA support
- Two USB 2.0 interfaces
 - One host and one configurable host/device interface, each with built-in PHY
- Flexible Storage Media Input / Output (SMIO) interface
 - NAND Flash controller
 - Up to 8-Gbit device, 512-Byte and 2-KByte page sizes
 - 8-bit flash chip data bus
 - 4-bit and 8-bit SLC with ECC hardware and read-confirm support
 - BCH error correction and increased spare area available
 - Three SD controllers (SD0, SD1, SD2)
 - SD0:
 - SDIO v3.0, SD, SDHC, SDXC, MMC and eMMC operation with boot support and UHS-I speed

A12A35 Chip Datasheet - Preliminary

- SD1:
 - SDIO v3.0, SD, SDHC, SDXC, MMC and eMMC operation
- SD2:
 - SDIO v1.0, SD, SDHC, SDXC, MMC and eMMC operation
- 32-GByte maximum capacity for SDHC SD Card
- 2-TByte maximum capacity for SDXC SD Card
- 1-bit, 4-bit and 8-bit SD modes, CRC7 for command and CRC16 for data integrity
- Multiple boot options
 - SPI-NOR, NAND Flash, USB and eMMC
- Vector interrupt controller including VIC CPU-offload functionality
- SSI / SPI controller interfaces
 - Two SSI / SPI masters with up to eight device enables
 - One dedicated SSI / SPI slave port to connect to an external system master
- Two-wire serial Inter-Integrated Circuit (I2C) interfaces (x3)
 - Configurable I2C buses (x2)
 - One I2C bus dedicated for use with HDMI
- UART interface (x2)
 - DMA support
 - One interface supports flow control
- Infrared remote receiver interface which supports most popular protocols
- 114 General Purpose Input/Output (GPIO) short-height pins with individual pull-up/down control
- ADC (four channels) with high/low threshold interrupt generation and 12-bit resolution
- Built-in power controller for power-up/down sequencing
- Real Time Clock (RTC)
- Interval timing with eight general-purpose timers configurable as external event counters
- Watchdog timer (one)
- Stepper motor interface (five channels) with four-channel Micro-Stepper interface
- Four Pulse Width Modulators (PWM)
- JTAG In-Circuit Emulator (ICE) interface for debugging (one)
- 404-pin TFBGA package (15 mm x 15 mm)
- 28-nm CMOS Low Power (LP) technology
- Operating temperature from -20 C to +85 C

2. INTERFACES

2.1 Overview

This section summarizes the peripheral interfaces for the A12A35 chip as follows:

- (Section 2.2) SDRAM Interface
- (Section 2.3) Video Input (VIN) Interface
- (Section 2.4) Video Output (VOUT) Interfaces
- (Section 2.5) I2S Audio Interface
- (Section 2.6) Ethernet Interface
- (Section 2.7) USB Interfaces
- (Section 2.8) Smart Media Input/Output (SMIO) Interface
- (Section 2.9) SSI/SPI Interface
- (Section 2.10) IDC Interface
- (Section 2.11) UART Interface
- (Section 2.12) InfraRed Remote Interface
- (Section 2.13) General Purpose Input/Output (GPIO) Interface
- (Section 2.14) Analog-to-Digital Converter (ADC) Interface
- (Section 2.15) Power Controller (PWC) and Real Time Clock (RTC) Interfaces
- (Section 2.16) Stepper, Micro-Stepper, and Pulse Width Modulator (PWM) Interfaces
- (Section 2.17) JTAG Interface

2.2 SDRAM Interface

The A12A35 chip includes a synchronous DRAM interface, enabling high data-access rates in response to pipelined commands. The features of the A12A35 SDRAM interface include:

- Frequencies up to 600 MHz
- Support for DDR3 and DDR3L operations
- Support for the LPDDR2/3 low-power DDR interface
- Programmable I/O strength
- 16-bit data bus

Please contact an Ambarella representative to select a qualified Ambarella-approved DDR component.

2.3 Video Input (VIN) Interface

The A12A35 chip supports two input channels, each with multiple serial and parallel input modes. The features of the A12A35 VIN interface include:

- Support for up to 8-lane SLVS / HiSPi input and up to 4-lane MIPI CSI input in the primary channel
- Up to 2-lane SLVS / HiSPi / MIPI inputs in the secondary channel
- Support for a single 10-lane SLVS / HiSPi sensor when the two input channels are combined
- Support for 14-bit parallel and LVCMOS sensors
- 16-bit CCIR.601 video input with external sync signals
- 8-bit, 10-bit, 12-bit or 14-bit BT.656 video input with embedded sync codes including full-data-range support

The following table summarizes the A12A35-supported input data formats, as well as their associated data ports and link types/speeds.

Data Format	Link Type/Speed	Port Selection
YUV (YCbCr)	$> 74.25 \text{ MHz} \leq 150 \text{ MHz}$	External LVCMOS YUV (YCbCr)
Sensor Data	LVCMOS $\leq 150 \text{ MHz}$	Parallel LVCMOS
Sensor Data	SLVS $\leq 700 \text{ Mbps}$	Serial SLVS
Sensor Data	MIPI $\leq 1 \text{ Gbps}$	Serial MIPI CSI

Table 2-1. Video Input Port Selection.

The A12A35 VIN module is part of the DSP cluster. Like other modules in the DSP cluster it is configured using a set of APIs. Please contact an Ambarella representative for information regarding VIN module configuration for a specific sensor.

2.3.1 Input Modes

The A12A35 chip supports the following input modes:

- (Section 2.3.1.1) Input Mode: External YUV Source
- (Section 2.3.1.2) Input Mode: Bayer Data Parallel Input LVCMOS
- (Section 2.3.1.3) Input Mode: Serial SLVS
- (Section 2.3.1.4) Input Mode: MIPI Camera Serial Interface (CSI)

2.3.1.1 Input Mode: External YUV Source

- Port: External LVCMOS YUV
- Pixel clock: **SPCLK_LVDS_P_0**
- Pixel data [7:0]: **SD_LVDS_P_[7:0]** (8-bit and 16-bit modes)
- Pixel data [15:8]: **SD_LVDS_N_[7:0]** (16-bit mode)
- HSync: **SPCLK_LVDS_N_0**
- VSync: **SPCLK_LVDS_N_1**
- SField: **SPCLK_LVDS_P_1**

2.3.1.2 Input Mode: Bayer Data Parallel Input LVCMOS

- Port: Parallel LVCMOS
- Pixel clock: **SPCLK_LVDS_P_0**
- Pixel data [7:0] (single-ended): **SD_LVDS_P_[7:0]**
- Pixel data [13:8] (single-ended): **SD_LVDS_N_[5:0]**
- HSync: **SPCLK_LVDS_N_0** (Slave Mode - Input is received from the video / sensor device)
SHSYNC (Master Mode - the A12A35 video input unit drives the sync operation)
- VSync: **SPCLK_LVDS_N_1** (Slave Mode)
SVSYNC (Master Mode)
- SField: **SPCLK_LVDS_P_1**

2.3.1.3 Input Mode: Serial SLVS

- Port: Serial SLVS
- For every four serial lanes, there should be one sync clock
- Includes support for one, two, four, or eight serial lanes
- Connect the input clock to **SPCLK_LVDS_P/N_[1:0]** as described in the table below. The skew between **SPCLK_LVDS_P/N_[1:0]** must be less than 600 ps.
- Connect the input data to **SD_LVDS_P/N_[7:0]** as described in the table below
- If only one clock is used then connect it to **SPCLK_LVDS_P/N_0**

Number of Data Lanes Used	Mapping	
	Clock	Data Lanes
2	SPCLK_LVDS_P/N_0	SD_LVDS_P/N_[1:0]
4	SPCLK_LVDS_P/N_0	SD_LVDS_P/N_[3:0]
8 (except as below*)	SPCLK_LVDS_P/N_0	SD_LVDS_P/N_[3:0]
	SPCLK_LVDS_P/N_1	SD_LVDS_P/N_[7:4]
*Sensors with only one CLK	SPCLK_LVDS_P/N_0	SD_LVDS_P/N_[7:0]

Table 2-2. SLVS: Sensor Input Port Clock Mapping for the SLVS Interface.

Note

1. The skew between **SPCLK_LVDS_P/N_[0:1]** must be maintained at less than 600 ps.

2.3.1.4 Input Mode: MIPI Camera Serial Interface (CSI)

- Port: Serial MIPI CSI
- Capability: Up to 4-lane MIPI CSI interface to compatible sensors
- Data Formats: Raw-8, Raw-10, Raw-12, Raw-14, YUV-422-8, and Generic-8
- Connect clock to **SPCLK_LVDS_P/N_0**
- Connect data lanes to **SD_LVDS_P/N_[3:0]**

2.4 Video Output (VOUT) Interfaces

The A12A35 Video Output (VOUT) interface supports a total of three output ports using two logical video channels.

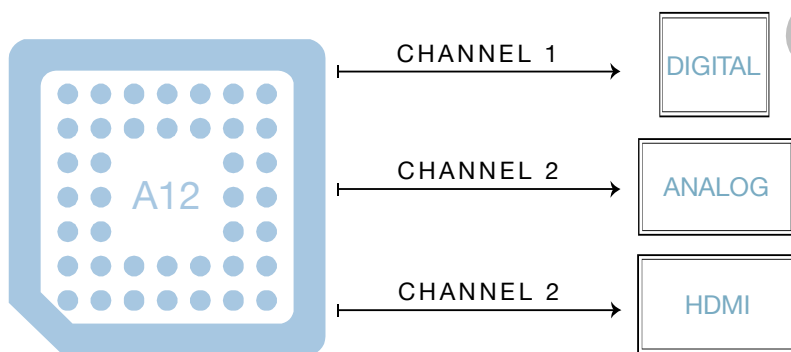

Figure 2-1. A12A35 Video Output Channels and Ports.

One VOUT channel is capable of driving digital output to RGB LCD panels, while the second VOUT channel drives either analog composite output or HDMI output to the on-chip HDMI transmitter (Tx) unit. The A12A35 chip supports simultaneous 1080i and 480i output rates.

2.4.1 Analog Video Output

The A12A35 video digital-to-analog converter (DAC) can drive standard-definition 480i/576i composite video outputs. Refer to the “A12 Hardware Programming Reference Manual” for VOUT register programming details.

2.4.2 Digital Video Output

The A12A35 chip supports several digital video output modes including 8-bit or 16-bit {CbY, CrY}, LCD-RGB, CCIR.601, and BT.656 as described in the tables below.

Refer to the “A12 Hardware Programming Reference Manual” for VOUT register programming information.

Bits	Mapped To Signal	Notes
VDO_OUT[15:8]	Unused	
VDO_OUT[7:0]	Interleaved R,G,B	VDO_OUT[7] is MSB

Table 2-3. Digital RGB Mode (Video Output Modes 0/1/2 for 3-bit Output to the LCD).

Bits	Mapped To Signal	Notes
VDO_OUT[15:11]	Upper 5 bits of the Red channel	VDO_OUT[15] is the MSB
VDO_OUT[10:5]	Upper 6 bits of the Green channel	VDO_OUT[10] is the MSB
VDO_OUT[4:0]	Upper 5 bits of the Blue channel	VDO_OUT[4] is the MSB

Table 2-4. 5:6:5 RGB Mode (Video Output Mode 3 for 16-bit RGB Output to the LCD).

Bits	Mapped To Signal	Notes
VDO_OUT[15:8]	Unused	
VDO_OUT[7:0]	Interleaved Cb,Y,Cr,Y . . .	Output data rate is 13.5 MHz Clock rate is 27 MHz

Table 2-5. 656 YCbCr Mode (Video Output Mode 4 for D1 - 480i and 576 - Resolution).

Bits	Mapped To Signal	Notes
VDO_OUT[15:8]	Interleaved Cb,Cr	VDO_OUT[15] is the MSB
VDO_OUT[7:0]	Y	VDO_OUT[7] is the MSB

Table 2-6. 16-bit 656-YCbCr Mode (Video Output Mode 4) and 16-bit 601-YCbCr Mode (Video Output Mode 5).

Table 2-5 and Table 2-6 correspond to 4:2:2 output format.

2.4.3 HDMI Output

The A12A35 chip includes an embedded HDMI 1.4b transmitter that provides three lanes of transition-minimized differential signaling (TMDS) data and one clock lane. The features of the A12A35 HDMI interface include:

- Consumer Electronics Control (CEC) support, allowing command and control of up to 15 CEC-enabled devices
- An additional two-wire bus (IDC2) for secure key transfer (see [Section 2.10](#))

Refer to the “A12 Hardware Programming Reference Manual” for VOUT register programming details.

2.4.4 Supported Video Format Per Output Port

Video formats for the each of the A12A35 video output ports are summarized in the table below.

Video Format Output		Analog Composite	HDMI	Digital Video	Comments
SD	720x480i59.94	√	√	√	
	720x480i60	√	√	√	
	720x576i50	√	√	√	
	720x480p30/29.97	x	√	√	
ED	720x480p59.94	x	√	√	
	720x480p60	x	√	√	
	720x576p50	x	√	√	
HD	1280x720p25	x	√	√	
	1280x720p30	x	√	√	
	1280x720p50	x	√	√	
	1280x720p59.94	x	√	√	
	1280x720p60	x	√	√	
	1920x1080p24	x	√	√	
	1920x1080p25	x	√	√	
	1920x1080p30	x	√	√	
	1920x1080p50	x	√	√	
	1920x1080i59.94	x	√	√	
	1920x1080i60	x	√	√	
	1920x1080p60	x	√	√	

Table 2-7. Summary of Video Formats for Each Output Port; Where √ = Supported and x = Not Supported.

2.5 I2S Audio Interface

The A12A35 chip provides an Integrated Interchip Sound (I2S) controller for two-channel audio support. Features of the I2S interface include:

- Support for audio using an external analog-to-digital converter (ADC)
- I2S host interface support
- All data lanes are clocked by the same clock signal

Refer to the “A12 Hardware Programming Reference Manual” for I2S register programming details.

2.6 Ethernet Interface

The A12A35 Ethernet interface enables a host to transmit and receive data in compliance with the “IEEE 802.3-2002 Standard for Ethernet Based LANs”. Features include:

- Supports 10/100-Mbps data transfer rates with IEEE 802.3-compliant RMII and MII interfaces to communicate with an external Fast Ethernet PHY
- Supports both full-duplex and half-duplex operation
- MDIO Master interface (optional) for PHY device configuration and management
- A second 25-MHz clock pin for Ethernet PHY

2.7 USB Interfaces

The A12A35 SoC includes two USB 2.0 high-speed interfaces: one USB host and one USB host/device. The host interface (USB1) is configured as a master port, while the device interface (USB0) can be configured to operate in either master or slave mode. Features of the A12A35 USB interfaces include:

- One USB host and one configurable USB host/device, each with a built-in PHY
- USB power-on boot mode

Refer to the “A12 Hardware Programming Reference Manual” for USB register programming information.

2.8 Smart Media Input/Output (SMIO) Interface

The A12A35 chip provides Smart Media Input/Output (SMIO) pins as a flexible storage-media interface for NAND Flash and SD controllers. Features of the A12A35 SMIO interface include:

- NAND Flash controller
 - Up to 8-Gbit device, 512-Byte and 2-KByte page sizes

- 8-bit flash chip data bus
- 4-bit and 8-bit single-level cell (SLC) memory with error-correcting code (ECC) hardware and read-confirm support
 - Note that Ambarella has discovered and addressed a hardware bug inside the SLC NAND controller related to multi-bit ECC status handling. The symptom of this bug is that, during multi-bit ECC SLC NAND DMA operations, the ECC error status bit is occasionally set for data blocks containing no error. The root cause of the bug is that the ECC error status bit becomes sticky once there is any block with an ECC error during any previous transaction. Ambarella offers pure software multi-bit ECC management for SLC NAND flashes that require multi-bit ECC as a complete workaround.
- Three SD controllers (SD0, SD1, SD2)
 - SD0:
 - SDIO v3.0, SD, SDHC, SDXC, MMC and eMMC operation with boot support and UHS-I speed
 - SD1:
 - SDIO v3.0, SD, SDHC, SDXC, MMC and eMMC operation
 - SD2:
 - SDIO v1.0, SD, SDHC, SDXC, MMC and eMMC operation
 - 32-GByte maximum capacity for SDHC SD Card
 - 2-TByte maximum capacity for SDXC SD Card
 - 1-bit, 4-bit and 8-bit SD modes, cyclic redundancy check 7 (CRC-7) for command, and cyclic redundancy check 16 (CRC-16) for data integrity
- Power-on NAND Flash and eMMC boot modes

Refer to the “A12 Hardware Programming Reference Manual” for SMIO register programming details.

Controller	Capacity			UHS-1	MMC / eMMC	Boot Support	SDIO (1.0 or 3.0)
	SD	SDHC	SDXC				
SD0	√	√	√	√	√	√	3.0
SD1	√	√	√		√		3.0
SD2	√	√	√		√		1.0

Table 2-8. Supported SD Modes; Where √ = Supported.

2.9 SSI/SPI Interface

The A12A35 chip provides two Synchronous Serial Interface (SSI) / Serial Peripheral Interface (SPI) masters and one dedicated SSI/SPI slave for full-duplex data transmission support. Features of the A12A35 SSI/SPI interface include:

- SSI/SPI master control with DMA support for up to eight slave devices
- Dedicated SSI/SPI slave port for connection to an external system master
- SPI-NOR, SPI-EEPROM boot support included with DMA support

Refer to the “A12 Hardware Programming Reference Manual” for SSI/SPI register programming information.

Master	Number of Device Enables	Device Enable Pins	SSI/SPI Function	Default Polarity ¹
SSI0	4	SSIOEN0	ssi0_en0 Device Enable	Active Low
		SSIOEN1	ssi0_en1 Device Enable	Active Low
		SC_E0	ssi0_en2 Device Enable	Active Low
		TIMER2	ssi0_en3 Device Enable	Active Low
SSI1	4	ENET_RXD_0 or SC_A3	ssi1_en0 Device Enable	Active Low
		ENET_RXD_1 or SC_B0	ssi1_en1 Device Enable	Active Low
		ENET_RX_ER or SC_B1	ssi1_en2 Device Enable	Active Low
		ENET_CRSDV or SC_B2	ssi1_en3 Device Enable	Active Low

Table 2-9. A12A35 SSI / SPI Master with Device Enable Detail.

Note:

1. Each SSI / SPI device-enable has programmable polarity; i.e., the polarity can be assigned to meet peripheral requirements without external glue logic.

2.10 IDC Interface

The A12A35 SoC includes three Inter-Integrated Circuit (IDC) interfaces to provide bidirectional data communication between the chip and its peripheral devices. Features of the A12A35 IDC interfaces include:

- Two programmable IDC ports (IDC0 and IDC2)
- One IDC port (IDC1) dedicated for use with HDMI
- Protocol speeds up to 400 Kbps
- Support for single-master mode

Refer to the “A12 Hardware Programming Reference Manual” for IDC register programming details.

2.11 UART Interface

The A12A35 chip includes two Universal Asynchronous Receiver / Transmitter (UART) ports. Features of the A12A35 UART interface include:

- Support for direct memory access (DMA) and hardware flow control in UART Port 1
- Debugging support in UART Port 0
- A maximum baud rate of 115.2 Kbps for UART0, based on per-port software settings

Refer to the “A12 Hardware Programming Reference Manual” for UART register programming.

2.12 InfraRed Remote Interface

The A12A35 chip provides one InfraRed (IR) receiver interface to enable remote control functionality. The A12A35 IR pin receives input signals from the IR module, and these signals are decoded through software programming. Refer to the “A12 Hardware Programming Reference Manual” for IR register programming information.

2.13 General Purpose Input/Output (GPIO) Interface

The A12A35 SoC includes 114 CMOS pins which can be programmed for multi-use General Purpose Input/Output (GPIO) functions. Features of the A12A35 GPIO interface include:

- Pins with reduced electrostatic discharge sensitivity, tested to the latest JEDEC standard (*Joint Standard for Component-Level Electrostatic Discharge Sensitivity Testing*)
- Four GPIO controllers
- Multiplexing support, allowing GPIO pins to be assigned multiple functions that can be independently enabled via software
- Individual pull-up/down control
- Individual drive strength control

Refer to the “A12 Hardware Programming Reference Manual” for GPIO register programming details.

2.14 Analog-to-Digital Converter (ADC) Interface

The A12A35 chip provides multiple channels for analog-to-digital conversion (ADC). Features of the A12A35 ADC interface include:

- Four channels
- High/low threshold interrupt generation
- 12-bit resolution

Refer to the “A12 Hardware Programming Reference Manual” for ADC register programming information.

2.15 Power Controller (PWC) and Real Time Clock (RTC) Interfaces

To conserve power, the A12A35 system software optimizes clock and PLL frequencies according to operating mode. Peripheral clocks can be further optimized by the user through register programming. Refer to the “A12 Hardware Programming Reference Manual” for information regarding register programming with peripheral clocks.

Features of the power controller (PWC) and real-time clock (RTC) interfaces include:

- 32-bit embedded RTC maintained with one dedicated always-on power supply pin
- RTC provides current time, alarm set, and power-on and power-off sequence generation

Refer to the “A12 Hardware Programming Reference Manual” for PWC/RTC register programming details.

2.16 Stepper, Micro-Stepper, and Pulse Width Modulator (PWM) Interfaces

2.16.1 Stepper and Micro-Stepper Motor Controllers

The A12A35 chip supports five stepper motor controller channels, each of which can be used for independent motor control. The chip also provides four sets of micro-stepper interfaces.

Refer to the “A12 Hardware Programming Reference Manual” for stepper and micro-stepper register programming information.

2.16.2 Pulse Width Modulator (PWM)

The A12A35 chip provides four pulse width modulation interfaces (PWMB0/B1/C0/C1):

- The four PWM outputs are referred to as `pwm_[0:3]`. Functionally:
 - PWMB0 is associated with `pwm_0`
 - PWMB1 is associated with `pwm_1`
 - PWMC0 is associated with `pwm_2`
 - PWMC1 is associated with `pwm_3`
- Note that in addition to the PWM controller embedded in the stepper motor controller, the A12A35 external pin **VD_PWM** can also serve as a PWM controller.
- Selection of PWM functions is executed via software. `pwm_[0:3]` are typically used for motor control and are sourced to the video input clock **CLK_SI**.

Refer to the “A12 Hardware Programming Reference Manual” for PWM register programming details.

2.17 JTAG Interface

The A12A35 chip provides an interface for JTAG In-Circuit Emulator (ICE) debugging. Contact an Ambarella representative for more information regarding the JTAG interface.

3. PINS

3.1 Pins: Overview

The A12A35 SoC is equipped with 404 external physical pins including power balls, ground balls, and signal balls. This section provides pin details for the primary chip interfaces and functions.

- Refer to [Section 4.4](#) for a list of fail-safe CMOS pins and their corresponding voltage thresholds.
- Refer to [Chapter 7](#) for a complete list of pins sorted by their location on the A12A35 ball map.
- Refer to the “*A12 Hardware Programming Reference Manual*” for GPIO multi-function selection information.

3.2 Pins: Tables

This section lists the pins for each interface as follows:

- (Section 3.2.1) Pins: SDRAM
- (Section 3.2.2) Pins: Sensor / Video Input
- (Section 3.2.3) Pins: Video Output
- (Section 3.2.4) Pins: I2S Digital Audio
- (Section 3.2.5) Pins: Ethernet Interface
- (Section 3.2.6) Pins: USB
- (Section 3.2.7) Pins: Smart Media Input/Output (SMIO)
- (Section 3.2.8) Pins: SSI / SPI
- (Section 3.2.9) Pins: IDC
- (Section 3.2.10) Pins: UART
- (Section 3.2.11) Pins: InfraRed Remote
- (Section 3.2.12) Pins: General Purpose Input/Output (GPIO)
- (Section 3.2.13) Pins: Analog to Digital Conversion (ADC)
- (Section 3.2.14) Pins: Power Controller (PWC) and Real Time Clock (RTC)
- (Section 3.2.15) Pins: Timer
- (Section 3.2.16) Pins: Stepper Controller
- (Section 3.2.17) Pins: Pulse Width Modulator (PWM)
- (Section 3.2.18) Pins: JTAG Control
- (Section 3.2.19) Pins: Global and Test
- (Section 3.2.20) Pins: Power, Ground and PLL

For each pin listed, the following information is provided:

- Pin direction: (I) input, (O) output, (S) supply, (G) ground
- Pad type
- A brief description
- For complete multiplexing information, please refer to [Section 3.2.12](#) and [Chapter 7](#).

3.2.1 Pins: SDRAM

Name	Location	Dir	Type	Description
DDR_ADDR [0:15]	A21, A22, B19, B21, B22, C21, C22, D21, D22, E19, E20, E21, E22, F21, F22, G21	O	SSTL18	Address for row address strobe (RAS) and column address strobe (CAS)
DDR_BA [0:2]	D19, C20, F20	O	SSTL18	Bank address
DDR_CALIBR	A6	I/O	Analog	DDR3 - ZQ calibration LPDDR2 - NC
DDR_CAS	C18	O	SSTL18	Column address strobe (active low)
DDR_CK	B18	O	SSTL18	DRAM clock per SDRAM
DDR_CK_BAR	A18	O	SSTL18	DDR_CK and DDR_CK_BAR are differential clocks
DDR_CK_2	B20	O	SSTL18	DRAM clock per SDRAM (unused with 32-bit SDRAM)
DDR_CK_2_BAR	A20	O	SSTL18	DDR_CK_2 and DDR_CK_2_BAR are differential clocks
DDR_CKE	A19	O	SSTL18	Clock enable
DDR_CS	F19	O	SSTL18	Chip select
DDR_CS_2	D20	O	SSTL18	
DDR_DM [0:3]	A12, B15, B9, C10	O	SSTL18	Data write mask (1 bit per 8 data bits)
DDR_DQ [0:31]	A14, A17, A7, B10, B12, B14, B17, B6, B7, C11, C12, C13, C14, C15, C16, C17, C6, C7, C8, C9, D10, D11, D13, D14, D15, D16, D17, D6, D7, D8, D9	I/O	SSTL18	Bi-directional data bus
DDR_DQS [0:3]	B11, B13, B16, B8	I/O	SSTL18	Data strobe (1 bit per 8 data bits) Output with write data, center-aligned Input with read data, edge-aligned
DDR_DQS_BAR [0:3]	A11, A13, A16, A8	I/O	SSTL18	DDR_DQS [N] and DDR_DQS_BAR [N] are differential signals
DDR_ODT	G19	O	SSTL18	SDRAM on-die termination control signal
DDR_RAS	D18	O	SSTL18	Row address strobe (active low)
DDR_RESET	G22	O	SSTL18	DDR3 - Asynchronous reset LPDDR2 - NC

Name	Location	Dir	Type	Description
DDR_WE	C19	O	SSTL18	Write enable (active low)
DDR_VDDQ_CKE	G20	S	Digital Supply	DDR power - clock enable Tied to internal pin DDR_CKEIN
DDR_VREF_[2:3]	A15, A9	I/O	SSTL18	Reference Voltage for SSTL18 pad ($0.5 * \text{DDR_VDDQ}$)
DDR_VDDQ_[L]	D12, E9, E10, E11, E12, E13, E14, E15, H8, H9, H10, H11, H12, H13, H14, H15	S	Digital Supply	DDR digital I/O power supply

Table 3-1. SDRAM Pins.

3.2.2 Pins: Sensor / Video Input

3.2.2.1 VIN Pins: Primary Sensor Interface

Name	Location	Dir	Type	Description
CLK_SI	N5	I/O	CMOS	Sensor master clock output
SD_LVDS_N_[0:9]	AA10, AA11, AA12, AA13, AA15, AA16, AA17, AA18, AA8, AA9	I	Sub-LVDS/ SLVS/ LVCMOS /MIPI	Sensor data Differential for sub-LVDS and MIPI Single-ended for LVCMOS mode.
SD_LVDS_P_[0:9]	AB10, AB11, AB12, AB13, AB15, AB16, AB17, AB18, AB8, AB9	I	Sub-LVDS/ SLVS/ LVCMOS /MIPI	Termination resistor built in for sub-LVDS / SLVS mode. Both single and double data rates supported.
SHSYNC	Y15	O	CMOS	H-Sync / H-Valid with Master mode configuration
SPCLK_LVDS_N_[0:2]	AA14, AA19, AA7	I	Sub-LVDS/ SLVS/ LVCMOS /MIPI	Sensor pixel clock Differential pairs for sub-LVDS and SLVS mode.
SPCLK_LVDS_P_[0:2]	AB14, AB19, AB7	I	Sub-LVDS/ SLVS/ LVCMOS /MIPI	SPCLK_LVDS_P_0 is used for single-ended pixel clock with LVCMOS mode.
SVSYNC	Y16	I/O	CMOS	V-Sync / V-Valid with Master mode configuration
LVDS_VDDA18_[L]	W8, W9	S	Analog Supply	VIN analog power (common to primary and secondary sensors)

Name	Location	Dir	Type	Description
LVDS_VSSA_[L]	Y10, Y9	G	Analog Ground	VIN analog ground (common to primary and secondary sensors)

Table 3-2. Primary VIN Sensor Interface Pins.

Note:

1. When the secondary VIN interface is active, the primary VIN uses data lanes **SD_LVDS_N [0:7]** and **SD_LVDS_P [0:7]**.
2. If the primary VIN is configured to LVCMOS mode, the secondary VIN supports SLVS/HiSPi only (i.e., no MIPI support).

3.2.2.2 VIN Pins: Secondary Sensor Interface

Name	Location	Dir	Type	Description
SD_LVDS_N [8:9]	AA8, AA9	I	SubLVDS/ SLVS/ MIPI	Sensor data Differential for sub-LVDS and MIPI
SD_LVDS_P [8:9]	AB8, AB9	I	SubLVDS/ SLVS/ MIPI	Termination resistor built in for sub-LVDS / SLVS mode. Both single and double data rates supported.
SPCLK_LVDS_N [2]	AA7	I	SubLVDS/ SLVS/ MIPI	Sensor pixel clock
SPCLK_LVDS_P [2]	AB7	I	SubLVDS/ SLVS/ MIPI	Differential pairs for sub-LVDS and SLVS mode.

Table 3-3. Secondary VIN Sensor Interface Pins.

Note:

1. When the secondary VIN interface is active, the primary VIN uses data lanes **SD_LVDS_N [0:7]** and **SD_LVDS_P [0:7]**.

3.2.3 Pins: Video Output

This section covers video output Interface pins for Digital-to-Analog Conversion, Digital Video Output, and HDMI output.

3.2.3.1 VOUT Pins: Video Digital-to-Analog Conversion (DAC)

Name	Location	Dir	Type	Description
DAC_COMP	E1	I/O	Analog	Compensation pin
DAC_IO	F1	I/O	Analog	Composite CVBS output
DAC_RSET	G1	I/O	Analog	Reference resistor

Name	Location	Dir	Type	Description
DAC_VREFIN	E2	I/O	Analog	Voltage reference input
VDAC_VDDA18	E4	S	Analog Supply	Video DAC analog power supply
VDAC_VDDA33	F2	S	Analog Supply	Video DAC analog power supply
VDAC_VSSA	E3	G	Analog Ground	Video DAC analog ground

Table 3-4. Video DAC Pins.

3.2.3.2 VOUT Pins: Digital Video Output

Name	Location	Dir	Type	Description ¹
VDO_CLK	V18	I/O	CMOS	Video output clock
VDO_HSYNC	W17	I/O	CMOS	Video output HSync signal
VDO_HVLD	V22	I/O	CMOS	Video output data
VDO_OUT_0	U19	I/O	CMOS	Video output data
VDO_OUT_1	W18	I/O	CMOS	Video output data
VDO_OUT_2	W16	I/O	CMOS	Video output data
VDO_OUT_3	T20	I/O	CMOS	Video output data
VDO_OUT_4	V16	I/O	CMOS	Video output data
VDO_OUT_5	Y18	I/O	CMOS	Video output data
VDO_OUT_6	Y20	I/O	CMOS	Video output data
VDO_OUT_7	V20	I/O	CMOS	Video output data
VDO_OUT_8	U18	I/O	CMOS	Video output data
VDO_OUT_9	V21	I/O	CMOS	Video output data
VDO_OUT_10	W20	I/O	CMOS	Video output data
VDO_OUT_11	U21	I/O	CMOS	Video output data
VDO_OUT_12	V19	I/O	CMOS	Video output data
VDO_OUT_13	V17	I/O	CMOS	Video output data
VDO_OUT_14	Y19	I/O	CMOS	Video output data
VDO_OUT_15	U22	I/O	CMOS	Video output data
VDO_VSYNC	W19	I/O	CMOS	Video output VSync signal

Table 3-5. Digital Video Output Pins.

Note:

1. A12A35 digital video output pins are used for power-on configuration (POC). For complete POC information, please refer to the "A12 Hardware Programming Reference Manual".

3.2.3.3 VOUT Pins: HDMI Output

Name	Location	Dir	Type	Description
CEC	W5	I/O	CMOS	Consumer Electronics Control (CEC) pin (3.3-V tolerance)
HDMI_CH0_M	M2	I/O	Analog	Transition-minimized differential signaling (TMDS) data out (open drain)
HDMI_CH0_P	M1			
HDMI_CH1_M	N2			
HDMI_CH1_P	N1			
HDMI_CH2_M	P2			
HDMI_CH2_P	P1			
HDMI_CLK_M	L2	I/O	Analog	Differential TMDS clock (open drain)
HDMI_CLK_P	L1	I/O	Analog	
HDMI_REXT	K1	I/O	Analog	Reference resistor - 10 KOhms (1% tolerance) (Required even if HDMI port is unused)
HPD	K2	I/O	CMOS	Hot-plug detect (3.3-V tolerance)
HDMI_AVDD25	L3	S	Analog Supply	HDMI analog power
HDMI_AVDDFLESD	L4	S	Analog Supply	HDMI analog power (Electrostatic Discharge)
HDMI_VDD10_[L]	M3, M4	S	Digital Supply	HDMI digital power
HDMI_VDDA_[L]	K4, J4		Analog Supply	HDMI analog power
HDMI_VSSA_[L]	J3, K3	G	Analog Ground	HDMI analog ground

Table 3-6. HDMI Output Pins.
3.2.4 Pins: I2S Digital Audio

Name	Location	Dir	Type	Description
CLK_AU	M5	O	CMOS	Master clock for external audio codec
I2S_CLK	U1	I/O	CMOS	I2S Controller audio bit clock
I2S_SI	W1	I	CMOS	I2S Controller serial data in
I2S_SO	V2	O	CMOS	I2S Controller serial data out
I2S_WS	V1	I/O	CMOS	I2S Controller word select

Table 3-7. I2S Controller Pins.

3.2.5 Pins: Ethernet Interface

Name	Location	Dir	Type	Description
ENET_REF_CLK	Y22	I/O	CMOS	Reference clock
ENET_CRS_DV	AA20	I/O	CMOS	Carrier sense
ENET_RXD_0	AB22	I/O	CMOS	Receive data
ENET_RXD_1	AA22	I/O	CMOS	
ENET_RX_ER	AB20	I/O	CMOS	Receive data error
ENET_TXD_0	AB21	I/O	CMOS	Transmit data
ENET_TXD_1	AA21	I/O	CMOS	
ENET_TXEN	Y21	I/O	CMOS	Transmit ready

Table 3-8. Ethernet Pins.
3.2.6 Pins: USB

Name	Location	Dir	Type	Description
GPIO_[1:2]	H3, G3	I/O	CMOS	USB EHCI overcurrent detect input ^{1,2}
GPIO_[3:4]	G4, H4	I/O	CMOS	USB EHCI port power enable out ^{1,2}
DETECT_VBUS	W6	I/O	CMOS	USB slave bus detect
USB0_DM	AA5	I/O	Analog	USB0 data. DP/DM are differential signals.
USB0_DP	AB5	I/O	Analog	
USB0_REXT	AA4	I/O	Analog	USB0 resistor
USB1_DM	AA6	I/O	Analog	USB1 data. DP/DM are differential signals.
USB1_DP	AB6	I/O	Analog	
USB1_REXT	Y6	I/O	Analog	USB1 resistor
USB_DVDD	AB4	S	Analog Supply	USB analog power supply
USB_VDDA18_[L]	AA3, AB3	S	Analog Supply	USB analog power supply
USB_VDDA33_[L]	Y4, Y5	S	Analog Supply	USB analog power supply
USB_VSSA_[L]	Y7, Y8	G	Analog Ground	USB analog ground

Table 3-9. USB Interface Pins.
Notes:

- GPIO1** (OVT0) / **GPIO3** (PWR0) internal are used for USB1
- GPIO2** (OVT1) / **GPIO4** (PWR1) internal are used for USB0

3.2.7 Pins: Smart Media Input/Output (SMIO)

- The Smart Media Input/Output (SMIO) pins are CMOS type and programmable input/output.
- SMIO pins are shared by controllers for NAND Flash (NAND) and SD / SDIO / SDHC / SDXC / MMC / eMMC (SD).
- SMIO pins use **SMIO_[N]** for the primary function name.

Name	GPIO	Loc.	NAND		SD		Description
			Function	Dir	Function	Dir	
SMIO_0	55	P22	nand_ce	O			NAND chip enable
SMIO_1	56	N22	nand_rb	I/O			NAND ready / busy
SMIO_2	57	H22			sd_clk	O	SD0 clock
SMIO_3	58	J22			sd_cmd	I/O	SD0 command
SMIO_4	59	M22			sd_cd	I/O	SD0 card detect
SMIO_5	60	K22			sd_wp	I/O	SD0 write protect
SMIO_6	61	R22	nand_re	O			NAND read enable
SMIO_7	62	R21	nand_we	O			NAND write enable
SMIO_8	63	T20	nand_ale	O			NAND address latch enable
SMIO_9	64	N21	nand_d[0]	I/O			NAND data
SMIO_10	65	M21	nand_d[1]	I/O			NAND data
SMIO_11	66	N20	nand_d[2]	I/O			NAND data
SMIO_12	67	M20	nand_d[3]	I/O			NAND data
SMIO_13	68	L20	nand_d[4]	I/O			NAND data
SMIO_14	69	L21	nand_d[5]	I/O			NAND data
SMIO_15	70	L22	nand_d[6]	I/O			NAND data
SMIO_16	71	P20	nand_d[7]	I/O			NAND data
SMIO_17	72	R20	nand_cle	O			NAND command latch enable
SMIO_18	73	P21			sd_d[0]	I/O	SD0 data
SMIO_19	74	K21			sd_d[1]	I/O	SD0 data
SMIO_20	75	J21			sd_d[2]	I/O	SD0 data
SMIO_21	76	H21			sd_d[3]	I/O	SD0 data
SMIO_22	77	J20			sd_d[4]	I/O	SD0 data
SMIO_23	78	K20			sd_d[5]	I/O	SD0 data
SMIO_24	79	L19			sd_d[6]	I/O	SD0 data
SMIO_25	80	H20			sd_d[7]	I/O	SD0 data
SMIO_26	81	M19			sdio_clk	O	SD1 clock
SMIO_27	82	N19			sdio_cmd	I/O	SD1 command
SMIO_28	83	P19			sdio_d[0]	I/O	SD1 data
SMIO_29	84	R19			sdio_d[1]	I/O	SD1 data
SMIO_30	85	T22			sdio_d[2]	I/O	SD1 data
SMIO_31	86	T21			sdio_d[3]	I/O	SD1 data
SMIO_32	87	U20			sdio_cd	I/O	SD1 card detect
SMIO_33	88	T19			sdio_wp	I/O	SD1 write protect
SC_A0	7	N3			sdxc_cmd	I/O	SD2 command
SC_A1	8	N4			sdxc_cd	I/O	SD2 card detect

Name	GPIO	Loc.	NAND		SD		Description
			Function	Dir	Function	Dir	
SC_A2	9	P3			sdx_c_wp	I/O	SD2 write protect
SC_A3	10	P4			sdx_c_d[0]	I/O	SD2 data
SC_B0	11	P5			sdx_c_d[1]	I/O	SD2 data
SC_B1	12	R5			sdx_c_d[2]	I/O	SD2 data
SC_B2	13	R4			sdx_c_d[3]	I/O	SD2 data
SC_B3	14	T5			sdx_c_d[4]	I/O	SD2 data
SC_C0	15	R2			sdx_c_d[5]	I/O	SD2 data
SC_C1	16	R1			sdx_c_d[6]	I/O	SD2 data
SC_C2	17	T1			sdx_c_d[7]	I/O	SD2 data
SC_C3	18	T2			sdx_c_CLK	O	SD2 clock
GPIO_0	0	J2			sd_hs_sel	I/O	SD0 high speed. Switch the SDXC power source from 1.8 V to 3.3 V.
WP	54	V5	nand_wp			I/O	NAND write protect

Table 3-10. Storage Media Interface Pins (SMIO) in NAND Flash and SD Modes.

3.2.8 Pins: SSI / SPI

Name	Location	Dir	Pad Type	Description
SSIOCLK	Y1	I/O	CMOS	ssi0 master port bit clock
SSIOEN0	AB1	O	CMOS	ssi0_en0 device enable
SSIOEN1	AA1	O	CMOS	ssi0_en1 device enable
SC_E0	R3	I/O	CMOS	ssi0_en2 device enable
TIMER2	U3	I/O	CMOS	ssi0_en3 device enable
ENET_RXD_0 or SC_A3	AB22, P4	I/O	CMOS	ssi1_en0 device enable
ENET_RXD_1 or SC_B0	AA22, P5	I/O	CMOS	ssi1_en1 device enable
ENET_RX_ER or SC_B1	AB20, R5	I/O	CMOS	ssi1_en2 device enable
ENET_CRSDV or SC_B2	AA20, R4	I/O	CMOS	ssi1_en3 device enable
SSIOMISO	W2	I	CMOS	ssi0 master port data in
SSIOMOSI	Y2	O	CMOS	ssi0 master port data out

Table 3-11. SSI / SPI Interface Pins.

3.2.9 Pins: IDC

Name	Location	Dir	Pad Type	Description
IDCCLK	Y3	I/O	CMOS	First IDC serial port - clock
IDCDATA	W3	I/O	CMOS	First IDC serial port - data
IDC2CLK	AA2	I/O	CMOS	Second IDC serial port - clock Reserved for HDMI
IDC2DATA	AB2	I/O	CMOS	Second IDC serial port - data Reserved for HDMI
IDC3CLK	V4	I/O	CMOS	Third IDC serial port - clock
IDC3DATA	W4	I/O	CMOS	Third IDC serial port - data

Table 3-12. IDC Interface Pins.
3.2.10 Pins: UART

Name	Location	Dir	Pad Type	Description
UARTORX	V7	I	CMOS	UART Port 0 receive
UARTOTX	W7	O	CMOS	UART Port 0 transmit
SC_D2	U5	I/O	CMOS	UART Port 1 flow control
SC_D3	U4	I/O	CMOS	UART Port 1 flow control
SC_D0	T3	I	CMOS	UART Port 1 receive
SC_D1	T4	O	CMOS	UART Port 1 transmit

Table 3-13. UART Interface Pins.
3.2.11 Pins: InfraRed Remote

Name	Location	Dir	Pad Type	Description
IR_IN	V6	I	CMOS	InfraRed input

Table 3-14. InfraRed Remote Interface Pins.

3.2.12 Pins: General Purpose Input/Output (GPIO)

The table below lists the General-Purpose Input/Output (GPIO) pins on the A12A35 chip. GPIO pins have multi-function capabilities and are CMOS-type programmable input/output. The function name that appears on the chip ball map is indicated in the **Pin Name** column. Refer to [Chapter 7](#) for map locations. For complete function selection information, refer to the “A12 Hardware Programming Reference Manual”.

GPIO	Pin Name	Multiplexed Function				
		First	Second	Third	Fourth	Fifth
0	GPIO_0	sd_hs_sel				
1	GPIO_1	ehci_app_prt_ovcurr0	uart_ahb_rx	ssis_sclk	sc_c0	
2	GPIO_2	ehci_app_prt_ovcurr1	uart_ahb_tx	ssis_rxd	sc_c1	
3	GPIO_3	ehci_prt_pwr_0	uart_ahb_cts_n	ssis_txd	sc_c2	
4	GPIO_4	ehci_prt_pwr_1	uart_ahb_rts_n	ssis_en	sc_c3	
5	GPIO_5	pwm_1	idsp_pip_iopad_master_hsync	vin_strig0	sc_d0	uart_ahb_cts_n
6	GPIO_6	pwm_2	idsp_pip_iopad_master_vsync	vin_strig1	sc_d1	uart_ahb_rts_n
7	SC_A0	sc_a0	ssi1_sclk	norspi_clk	pwm_0	sdxc_cmd
8	SC_A1	sc_a1	ssi1_txd	norspi_dq[0]	pwm_1	sdxc_cd
9	SC_A2	sc_a2	ssi1_rxd	norspi_dq[1]	pwm_2	sdxc_wp
10	SC_A3	sc_a3	ssi1_en0	norspi_dq[2]	pwm_3	sdxc_d[0]
11	SC_B0	sc_b0	ssi1_en1	norspi_dq[3]		sdxc_d[1]
12	SC_B1	sc_b1	ssi1_en2	norspi_en[0]	norspi_dq[2]	sdxc_d[2]
13	SC_B2	sc_b2	ssi1_en3	norspi_en[1]	norspi_dq[3]	sdxc_d[3]
14	SC_B3	sc_b3	pwm_3	norspi_en[2]		sdxc_d[4]
15	SC_C0	sc_c0	uart_ahb_rx	ssis_sclk		sdxc_d[5]
16	SC_C1	sc_c1	uart_ahb_tx	ssis_rxd	enet_crs	sdxc_d[6]
17	SC_C2	sc_c2	uart_ahb_cts_n	ssis_txd	enet_rxd_2	sdxc_d[7]
18	SC_C3	sc_c3	uart_ahb_rts_n	ssis_en	enet_rxd_3	sdxc_clk
19	SC_D0	sc_d0	uart_ahb_rx	ssis_sclk	enet_col	pwm_0
20	SC_D1	sc_d1	uart_ahb_tx	ssis_rxd	enet_tx_clk	pwm_1
21	SC_D2	sc_d2	uart_ahb_cts_n	ssis_txd	enet_tx_er	pwm_2
22	SC_D3	sc_d3	uart_ahb_rts_n	ssis_en	enet_txd_2	pwm_3
23	SC_E0	sc_e0	ssi0_en2	norspi_en[3]	enet_txd_3	pwm_1
24	TIMER0	tm11_clk			enet_2nd_ref_clk	
25	TIMER1	tm12_clk		idsp_pip_iopad_master_hsync	enet_mdc	
26	TIMER2	tm13_clk	ssi0_en3	idsp_pip_iopad_master_vsync	enet_mdio	
27	IDCCLK	idc0clk				
28	IDCDATA	idc0data				
29	IDC2CLK	idc1clk		norspi_dq[2]	norspi_en[2]	
30	IDC2DATA	idc1data		norspi_dq[3]	norspi_en[3]	
31	IDC3CLK	idc2clk	vin_strig0			
32	IDC3DATA	idc2data	vin_strig1			



GPIO	Pin Name	Multiplexed Function				
		First	Second	Third	Fourth	Fifth
33	IR_IN	ir_in				
34	SSIOCLK	ssi0_sclk	norspi_clk	uart_ahb_rx	ssis_sclk	
35	SSIOMOSI	ssi0_txd	norspi_dq[0]	uart_ahb_tx	ssis_rxd	
36	SSIOMISO	ssi0_rxd	norspi_dq[1]	uart_ahb_cts_n	ssis_txd	
37	SSIOENO	ssi0_en0	norspi_en[0]	uart_ahb_rts_n	ssis_en	
38	SSIOEN1	ssi0_en1	norspi_en[1]			
39	UARTORX	uart0rx	uart_ahb_rx			
40	UARTOTX	uart0tx	uart_ahb_tx			
41	I2S_CLK	i2s_clk				
42	I2S_SI	i2s_si				
43	I2S_SO	i2s_so				
44	I2S_WS	i2s_ws				
45	CLK_AU					
46	ENET_TXEN	enet_txen	sc_a0	enet_txen	ssi1_sclk	norspi_clk
47	ENET_TXD_0	enet_txd_0	sc_a1	enet_txd_0	ssi1_txd	norspi_dq[0]
48	ENET_TXD_1	enet_txd_1	sc_a2	enet_txd_1	ssi1_rxd	norspi_dq[1]
49	ENET_RXD_0	enet_rxd_0	sc_a3	enet_rxd_0	ssi1_en0	norspi_en[0]
50	ENET_RXD_1	enet_rxd_1	sc_b0	enet_rxd_1	ssi1_en1	norspi_en[1]
51	ENET_RXER	enet_rxer	sc_b1	enet_rxer	ssi1_en2	norspi_en[2]
52	ENET_CRSDV	enet_crs_dv	sc_b2	enet_crs_dv	ssi1_en3	norspi_dq[2]
53	ENET_REFCLK	enet_ref_clk	sc_b3	enet_rx_clk		norspi_dq[3]
54	WP		nand_wp			
55	SMIO_0		nand_ce	norspi_clk		
56	SMIO_1		nand_rb	norspi_dq[4]		
57	SMIO_2		sd_clk			
58	SMIO_3		sd_cmd			
59	SMIO_4		sd_cd			
60	SMIO_5		sd_wp			
61	SMIO_6		nand_re	norspi_dq[5]		
62	SMIO_7		nand_we	norspi_dq[6]		
63	SMIO_8		nand_ale	norspi_dq[7]		
64	SMIO_9		nand_d[0]	norspi_en[0]		
65	SMIO_10		nand_d[1]	norspi_en[1]		
66	SMIO_11		nand_d[2]	norspi_en[2]		
67	SMIO_12		nand_d[3]	norspi_en[3]		
68	SMIO_13		nand_d[4]	norspi_dq[0]		
69	SMIO_14		nand_d[5]	norspi_dq[1]		
70	SMIO_15		nand_d[6]	norspi_dq[2]		
71	SMIO_16		nand_d[7]	norspi_dq[3]		
72	SMIO_17		nand_cle			
73	SMIO_18		sd_d[0]			



GPIO	Pin Name	Multiplexed Function				
		First	Second	Third	Fourth	Fifth
74	SMIO_19		sd_d[1]			
75	SMIO_20		sd_d[2]			
76	SMIO_21		sd_d[3]			
77	SMIO_22		sd_d[4]		sc_c0	ssis_sclk
78	SMIO_23		sd_d[5]		sc_c1	ssis_rxd
79	SMIO_24		sd_d[6]		sc_c2	ssis_txd
80	SMIO_25		sd_d[7]		sc_c3	ssis_en
81	SMIO_26		sdio_clk			
82	SMIO_27		sdio_cmd			
83	SMIO_28		sdio_d[0]		sc_d0	ssis_sclk
84	SMIO_29		sdio_d[1]		sc_d1	ssis_rxd
85	SMIO_30		sdio_d[2]		sc_d2	ssis_txd
86	SMIO_31		sdio_d[3]		sc_d3	ssis_en
87	SMIO_32		sdio_cd			
88	SMIO_33		sdio_wp			
89	HPD	hdmitx_hpd				
90	CEC	hdmitx_cec	enet_2nd_ref_clk			
91	SVSYNC	vin_svsync	idsp_pip_iopad_master_hsync			
92	SHSYNC	vin_shsync	idsp_pip_iopad_master_vsync			
93	VDO_OUT_0	vd0_out[0]				
94	VDO_OUT_1	vd0_out[1]				
95	VDO_OUT_2	vd0_out[2]				
96	VDO_OUT_3	vd0_out[3]				
97	VDO_OUT_4	vd0_out[4]				
98	VDO_OUT_5	vd0_out[5]				
99	VDO_OUT_6	vd0_out[6]				
100	VDO_OUT_7	vd0_out[7]				
101	VDO_OUT_8	vd0_out[8]				
102	VDO_OUT_9	vd0_out[9]				
103	VDO_OUT_10	vd0_out[10]				
104	VDO_OUT_11	vd0_out[11]				
105	VDO_OUT_12	vd0_out[12]				
106	VDO_OUT_13	vd0_out[13]				
107	VDO_OUT_14	vd0_out[14]				
108	VDO_OUT_15	vd0_out[15]				
109	VDO_CLK	vd0_clk				
110	VDO_VSYNC	vd0_vsync				
111	VDO_HSYNC	vd0_hsync				
112	VDO_HVLD	vd0_hvld				

GPIO	Pin Name	Multiplexed Function				
		First	Second	Third	Fourth	Fifth
113	VD_PWM	pwm_0				

Table 3-15. General Purpose Input Output (GPIO) Multifunction-Capable Pins.

3.2.13 Pins: Analog to Digital Conversion (ADC)

Name	Location	Dir	Type	Description
ADC_CH [0:3]	B4, C4, B3, C3	I	Analog	ADC analog input (4 channels)
ADC_CH_4				Reserved (Tie to analog ground)
ADC_VDDA18	E5	S	Analog Supply	ADC analog power supply
ADC_VDDA33	F3	S	Analog Supply	ADC analog power supply
ADC_VSSA	D3	G	Analog Ground	ADC analog ground

Table 3-16. ADC Interface Pins.

3.2.14 Pins: Power Controller (PWC) and Real Time Clock (RTC)

Name	Location	Dir	Type	Description
PWC_PC_REF	A1	I/O	Analog	Used to detect whether battery level is too low. Connect to voltage-divided version of PWC_PC_VDD .
PWC_PSEQ[1:3]	D5, C5, D4	O	CMOS	Power Up/Down control signals.
PWC_RSTINB	B5	I	CMOS	PWC reset input. Usually pulled up to PWC_PC_VDD through an RC circuit.
PWC_RSTOB	A5	O	CMOS	Reset signal out (also used as Power Up/Down signal)
PWC_RTC_CP	A3	S	Analog Supply	Power for RTC module and on-chip RTC oscillator. When PWC_RTC_CP is less than a specified voltage, the power controller will shut down and all registers will reset.
PWC_WKUP	F5	I	CMOS	In the power-off state, a positive pulse can only trigger a power on sequence.
PWC_WKUP1	F4			
XI_RTC	B2	I	XOSC	Connect to RTC crystal
XO_RTC	A2	O	XOSC	Connect to RTC crystal
PWC_PC_VDD	A4	S	Digital Supply	Power for power-management module Connected to external battery/adaptor clamping circuit. The PWC_PC_VDD voltage must be a specified minimum to block a WKUP[N] .

Table 3-17. PWC and RTC Interface Pins.

3.2.15 Pins: Timer

Name	Location	Dir	Type	Description
TIMER0	U2	I/O	CMOS	Interval Timer 0 external clock source
TIMER1	V3	I/O	CMOS	Interval Timer 1 external clock source
TIMER2	U3	I/O	CMOS	Interval Timer 2 external clock source

Table 3-18. Timer Pins.
3.2.16 Pins: Stepper Controller

Name	Location	Dir	Type	Description
SC_A0	N3	I/O	CMOS	Stepper Controller A
SC_A1	N4	I/O	CMOS	Stepper Controller A / Micro Stepper A
SC_A2	P3	I/O	CMOS	Stepper Controller A / Micro Stepper A
SC_A3	P4	I/O	CMOS	Stepper Controller A / Micro Stepper A
SC_B0	P5	I/O	CMOS	Stepper Controller B
SC_B1	R5	I/O	CMOS	Stepper Controller B / Micro Stepper B
SC_B2	R4	I/O	CMOS	Stepper Controller B / Micro Stepper B
SC_B3	T5	I/O	CMOS	Stepper Controller B / Micro Stepper B
SC_C0	R2	I/O	CMOS	Stepper Controller C
SC_C1	R1	I/O	CMOS	Stepper Controller C / Micro Stepper C
SC_C2	T1	I/O	CMOS	Stepper Controller C / Micro Stepper C
SC_C3	T2	I/O	CMOS	Stepper Controller C / Micro Stepper C
SC_D0	T3	I/O	CMOS	Stepper Controller D
SC_D1	T4	I/O	CMOS	Stepper Controller D / Micro Stepper D
SC_D2	U5	I/O	CMOS	Stepper Controller D / Micro Stepper D
SC_D3	U4	I/O	CMOS	Stepper Controller D / Micro Stepper D
SC_E0	R3	I/O	CMOS	Stepper Controller E

Table 3-19. Stepper / Microstepper Pins.

3.2.17 Pins: Pulse Width Modulator (PWM)

Name	Location	Dir	Type	Description
VD_PWM	W22	I/O	CMOS	Pulse Width Modulator Output
PWM_1	G4	I/O	CMOS	Pulse Width Modulator Output Typically used for motor control
PWM_2	H4	I/O	CMOS	Pulse Width Modulator Output Typically used for motor control
PWM_3	T5	I/O	CMOS	Pulse Width Modulator Output Typically used for motor control

Table 3-20. PWM Pins.
3.2.18 Pins: JTAG Control

Name	Location	Dir	Pad Type	Description
JTAG_CLK	C1	I	CMOS	Clock
JTAG_RST_L	D2	I	CMOS	Reset
JTAG_TDI	B1	I	CMOS	Data in
JTAG_TDO	D1	O	CMOS	Data out
JTAG_TMS	C2	I	CMOS	Test mode select

Table 3-21. JTAG Pins.
3.2.19 Pins: Global and Test

Name	Location	Dir	Type	Description
FSOURCE_0	K19	S	Power / Ground	Power supply during programming. Customer ties to digital ground for operation.
POR_L	V8	I	CMOS	Power-on reset pin (active low)
TEST_MODE	W21	I	CMOS	0 - Normal mode 1 - Test mode
XIN	H1	I	XOSC	24-MHz or 48-MHz crystal or crystal oscillator input
XOUT	J1	O	XOSC	

Table 3-22. Global and Test Pins.

3.2.20 Pins: Power, Ground and PLL

Name	Location	Dir	Type	Description
ADC_VDDA18	E5	S	Analog Supply	ADC analog power supply
ADC_VDDA33	F3	S	Analog Supply	ADC analog power supply
ADC_VSSA	D3	G	Analog Ground	ADC analog ground
DDR_VDDQ_[L]	D12, E9, E10, E11, E12, E13, E14, E15, H8, H9, H10, H11, H12, H13, H14, H15	S	Digital Supply	DDR digital I/O power supply
HDMI_AVDD25	L3	S	Analog Supply	HDMI analog power
HDMI_AVDDFLESD	L4	S	Analog Supply	HDMI analog power (Electrostatic Discharge)
HDMI_VDD10_[L]	M3, M4	S	Digital Supply	HDMI digital power
HDMI_VDDA_[L]	K4, J4	S	Analog Supply	HDMI analog power
HDMI_VSSA_[L]	J3, K3	G	Analog Ground	HDMI analog ground
LVDS_VDDA11	V9	S	Analog Supply	VIN analog power (common to primary and secondary sensors)
LVDS_VDDA18_[L]	W8, W9	S	Analog Supply	VIN analog power (common to primary and secondary sensors)
LVDS_VSSA_[L]	Y10, Y9	G	Analog Ground	VIN analog ground (common to primary and secondary sensors)
PWC_PC_VDD	A4	S	Digital Supply	Power for power management module Connected to external battery/adaptor clamping circuit. The PWC_PC_VDD voltage must be a specified minimum to block a WKUP[N] .
USB_DVDD	AB4	S	Analog Supply	USB analog power supply
USB_VDDA18_[L]	AA3, AB3	S	Analog Supply	USB analog power supply
USB_VDDA33_[L]	Y4, Y5	S	Analog Supply	USB analog power supply
USB_VSSA_[L]	Y7, Y8	G	Analog Ground	USB analog ground
VDAC_VDDA18	E4	S	Analog Supply	Video DAC analog power supply
VDAC_VDDA33	F2	S	Analog Supply	Video DAC analog power supply
VDAC_VSSA	E3	G	Analog Ground	Video DAC analog ground

Name	Location	Dir	Type	Description
VDD_[L]	M10, M11, M12, M13, M14, M9, N10, N11, N12, N13, N14, N9, P10, P11, P12, P13, P14, P9, R10, R11, R12, R13, R14, R9	S	Digital Supply	Digital power supply
VDD33_[L]	K18, L18, V12, V13, V14, V15, W12, W13, W14, W15	S	Digital Supply	Digital power supply
NAND_VDDO_[L]	H18, H19	S	Digital Supply	NAND Flash digital power
SD_VDDO_[L]	M18, N18	S	Digital Supply	SD controller digital power
SDIO_VDDO_[L]	J18, J19	S	Digital Supply	SDIO controller digital power
VDDA10_PLL_[L]	K5, L5	S	Analog Supply	PLL analog power
VDDA18_PLL	G5	S	Analog Supply	PLL analog power
VDDP18_[L]	P18, R18, T18, V10, V11, W10, W11	S	Digital Supply	I/O pre-driver power
VSS_[L]	E16, E17, E18, E6, E7, E8, F18, G18, J10, J11, J12, J13, J14, J15, J8, J9, K10, K11, K12, K13, K14, K15, K8, K9, L10, L11, L12, L13, L14, L15, L8, L9, M15, M8, N15, N8, P15, P8, R15, R8, Y11, Y12, Y13, Y14	G	Digital Ground	Digital ground

Table 3-23. Power, Ground and PLL Pins.

4. ELECTRICAL CHARACTERISTICS

4.1 Electrical: Overview

This section provides details on the electrical characteristics of the A12A35 chip as follows:

- (Section 4.1) Electrical: Overview
- (Section 4.2) Electrical: Absolute Ratings
- (Section 4.3) Electrical: Recommended Operating Conditions
- (Section 4.4) Electrical: Fail-Safe Pins
- (Section 4.5) Electrical: Video Signal Wave Forms and Timing
- (Section 4.6) Electrical: SD Controller Timing
- (Section 4.7) Electrical: eMMC Boot Timing

Note that the electrical details provided in this section are preliminary estimates.

4.2 Electrical: Absolute Ratings

The following table provides absolute ratings for the analog/digital voltages of the A12A35 power rails.

Parameter	Minimum	Maximum
Analog supply voltage (3.0 V)	-0.3 V	3.6 V
Digital supply voltage (3.0 V)	-0.3 V	3.6 V
Analog supply voltage (1.8 V)	-0.3 V	1.98 V
Digital supply voltage (1.8 V)	-0.3 V	1.98 V
Analog supply voltage (1.0 V)	-0.3 V	1.15 V
Digital supply voltage (1.0 V)	-0.3 V	1.15 V
Digital I/O range (V)	-0.3 V	3.6 V
	-0.3 V	1.98 V
Analog I/O range (V)	-0.3 V	3.6 V
	-0.3 V	1.98 V
Operating temperature (case) (°C)	-20 C to +85 C	
Storage temperature (°C)	-40 C to +85 C	
Thermal resistance (Θ_{jc}) (°C/W)	11.22 C/W	

Table 4-1. Absolute Ratings.

This Ambarella part will support a full range of operation at the case temperature specified above, provided that the customer's PCB design, manufacturing processes, and power supply design are equal to those of the Ambarella reference hardware platform in terms of quality. All other components used during system design are also required to operate successfully at the case temperature range specified above to guarantee proper overall system operation.

4.3 Electrical: Recommended Operating Conditions

This section continues with recommended operating conditions for:

- (Section 4.3.1) Operating Conditions: Power Rails - DC Characteristics
- (Section 4.3.2) Operating Conditions: Digital I/O
- (Section 4.3.3) Operating Conditions: DRAM I/O
- (Section 4.3.4) Operating Conditions: PWC and RTC Power Supply
- (Section 4.3.5) Operating Conditions: Video Sensor Input
- (Section 4.3.6) Operating Conditions: Video DAC
- (Section 4.3.7) Operating Conditions: ADC Electrical Specifications
- (Section 4.3.8) Operating Conditions: Crystal and Reference Clock Requirements

4.3.1 Operating Conditions: Power Rails - DC Characteristics

Parameter ¹	Comments	Minimum	Typical	Maximum	Ripple
ADC_VDDA18	Channel 0	1.7 V	1.8 V	1.9 V	2%
ADC_VDDA33	All other channels	2.85 V	3.0 V	3.6 V	2%
DDR_VDDQ_CKE / DDR_VDDQ	DDR3 Mode	1.4 V	1.5 V	1.6 V	2%
	DDR3L Mode	1.28 V	1.35 V	1.45 V	2%
	LPDDR2/3 Mode	1.14 V	1.2 V	1.3 V	2%
HDMI_PLL_VDD		0.97 V	1.0 V	1.03 V	2%
HDMI_VDDA_0		1.7 V	1.8 V	1.9 V	2%
HDMI_VDDA_ESD		2.85 V	3.0 V	3.15 V	2%
HDMI_VDDA_ESD_1P8V		1.7 V	1.8 V	1.9 V	2%
LVDS_VDDA11	Primary and Secondary Sensor SLVS Mode	0.97 V	1.0 V	1.03 V	2%
	Primary or Secondary Sensor MIPI Mode	1.08 V	1.1 V	1.13 V	2%
	Primary Sensor 1.8-V LVCMOS	1.7 V	1.8 V	1.9 V	2%
LVDS_VDDA18	Common	1.7 V	1.8 V	1.9 V	2%
PWC_PC_VDD		2.9 V	3.1 V	3.15 V	2%
USB_DVDD		0.97 V	1.0 V	1.03 V	2%
USB_VDD18_0		1.7 V	1.8 V	1.9 V	2%
USB_VDD33_0		2.85 V	3.0 V	3.15 V	2%
VDAC_AVDD18		1.7 V	1.8 V	1.9 V	2%
VDAC_AVDD33		2.85 V	3.0 V	3.15 V	2%
VDD		0.97 V	1.0 V	1.03 V	2%
VDD33		2.85 V	3.0 V	3.15 V	2%
VDD33_NAND	3.0-V mode	2.85 V	3.0 V	3.15 V	2%
	1.8-V mode	1.7 V	1.8 V	1.9 V	2%

Parameter ¹	Comments	Minimum	Typical	Maximum	Ripple
VDD33_SD / VDD33_SDIO	SD mode	2.85 V	3.0 V	3.15 V	2%
	SDXC mode	1.7 V	1.8 V	1.9 V	2%
VDDA10_PLL		0.97 V	1.0 V	1.03 V	2%
VDDA18_PLL		1.7 V	1.8 V	1.9 V	2%
VDDP18		1.7 V	1.8 V	1.9 V	2%

Table 4-2. Power Rails: DC Characteristics (Preliminary and Subject to Change).

Note:

- The electrical details provided in this section are preliminary estimates and are subject to change. Please contact an Ambarella representative for current electrical specifications.

4.3.2 Operating Conditions: Digital I/O

Parameter	Comments	Minimum	Typical	Maximum
VIL	Input Low Voltage	-0.3 V		0.7 V
VIH	Input High Voltage	2.0 V		3.6 V (for 3.3V-tolerant pins)
VOL	Output Low Voltage			0.4 V
VOH	Output High Voltage	2.4 V		

Table 4-3. Digital I/O Characteristics (Preliminary).

4.3.3 Operating Conditions: DRAM I/O
4.3.3.1 DRAM: DC Supply Voltage Levels

Parameter	Comments	Minimum	Typical	Maximum
DDR_VDDQ		See Section 4.3.1		
DDR_VDDQ_CKE		See Section 4.3.1		
VTT	Termination voltage	DDR_VREF - 0.04 V	DDR_VREF	DDR_VREF + 0.04 V
DDR_VREF	Input reference level	0.49 * DDR_VDDQ	0.5 * VDDQ	0.51 * DDR_VDDQ

Table 4-4. DRAM I/O Characteristics - DC Supply Voltage Levels (Preliminary).

4.3.3.2 DRAM: SSTL I/O DC Specifications

Parameter	Comments	Minimum	Typical	Maximum
VIHT	DC input logic threshold high			DDR_VREF + 0.05 V
VILT	DC input logic threshold low	DDR_VREF - 0.05 V		
VIH	DC input voltage high	DDR_VREF+100 mV		VDDQ + 0.3 V
VIL	DC input voltage low	-0.3 V		DDR_VREF-100 mV
VOH	DC output logic high	DDR_VDDQ		
VOL	DC output logic low			0 V
RTT1	RTT effective impedance	60 Ohms	75 Ohms	90 Ohms
RTT2	RTT effective impedance	120 Ohms	150 Ohms	180 Ohms

Table 4-5. DRAM I/O Characteristics - SSTL I/O DC Specifications (Preliminary).
4.3.4 Operating Conditions: PWC and RTC Power Supply

Parameter	Comments	Minimum	Typical	Maximum
PWC_RTC_CP	RTC module supply	1.2 V	2.4 V	2.6 V
PWC_PC_VDD	Power management supply	2.9 V	3.1 V	3.15 V
PWC_PC_REF	Reference voltage	1.3 V		1.8 V
VIH	For PWC_WKUP	0.7 * PWC_RTC_CP		
VIL	For PWC_WKUP			0.3 * PWC_RTC_CP
VOH	PWC_PSEQ[1:3]	0.9 * PWC_PC_VDD		
	PWC_RSTOB	0.9 * PWC_PC_VDD		

Table 4-6. PWC and RTC Supply.
4.3.5 Operating Conditions: Video Sensor Input

Parameter	Symbol	Comment	Min	Typ.	Max.
Supply Voltage	Analog	MIPI_VDDA18	1.7 V	1.8 V	2.0 V
	Interface	MIPI_VDDA11	1.04 V	1.1 V	1.15 V
	Digital	VDD	0.97 V	1.0 V	1.03 V
Digital Input Voltage	VIL	LVC MOS 1.1 V			0.45 V
		LVC MOS 1.8 V			0.6 V
	VIH	LVC MOS 1.1 V	0.7 V		
		LVC MOS 1.8 V	1.2 V		

Parameter	Symbol	Comment	Min	Typ.	Max.
Differential Input for SLVS	V_{CM}		0.2 V		1.0 V
	V_{DIFF}		70 mV		400 mV

Table 4-7. DC Characteristics: SLVS Interface.

4.3.5.1 VIN: MIPI Receiver DC Specification

Parameter	Comments	Minimum	Typical	Maximum
VIH	Logic 1 input voltage	880 mV		
VIL	Logic 0 input voltage, not in ULP state			550 mV
VIL-ULP	Logic 0 input voltage, ULP state			300 mV
VHYST	Input hysteresis	25 mV		

Table 4-8. MIPI Receiver DC Specification.

4.3.5.2 VIN: MIPI Receiver AC Specification

Description	Minimum	Typical	Maximum
Input pulse rejection			300 V-ps
Minimum pulse width response	20 ns		
Peak interference amplitude			200 mV
Interference frequency	450 MHz		

Table 4-9. MIPI Receiver AC Specification.

4.3.6 Operating Conditions: Video DAC

Parameter	Comments	Minimum	Typical	Maximum
VDD	Operating digital supply voltage	0.97 V	1.0 V	1.03 V
VDAC_AVDD18	Operating analog supply voltage	1.7 V	1.8 V	1.9 V
VDAC_AVDD33		2.85 V	3.0 V	3.15 V
I_{OFS}	IO out current		34.6 mA	
I_{OP}	Operating Current		36 mA	
V(IO)	Out voltage full scale	1.17 V	1.28 V	1.43 V
Resolution	DAC resolution			10 bits
DNL	Differential non-linearity error			±1 LSB
INL	Integral non-linearity error			±2 LSB
VREF	Reference Voltage			1.22 V

Table 4-10. Video DAC Electrical Specifications.

4.3.7 Operating Conditions: ADC Electrical Specifications
4.3.7.1 ADC Electrical: DC Specification

Parameter	Comments	Minimum	Typical	Maximum
VDD	Digital supply voltage	0.97 V	1.0 V	1.03 V
ADC_AVDD18	Analog supply (channel 0)	1.7 V	1.8 V	1.9 V
ADC_AVDD33	Analog supply (other channels)	2.85 V	3.0 V	3.15 V
IVDDA	Operating current (Fclk = 5 MHz and Fs = 1 MS/s)		4 mA	
VREF	Reference Voltage (Top) (Low reference is ADC_AVSS)	ADC_AVDD	ADC_AVDD	ADC_AVDD
VIN	Analog input voltage	ADC_AVSS		VREF
N	Resolution		12 bits	
INL	INL		±1 LSB	±4 LSB
DNL	DNL		±0.5 LSB	±1 LSB

Table 4-11. ADC DC Specification.

4.3.7.2 ADC Electrical: AC Specification

Parameter	Comments	Minimum	Typical	Maximum
Fs	Sampling rate	50 K		1 MS/s
FCLK	Sampling clock	300 K		6 MHz
SNDR	Signal-to-noise and distortion ratio (Fclk = 5 MHz and AIN = 50 KHz*)	54 dB	60 dB	

Table 4-12. ADC AC Specification.

4.3.8 Operating Conditions: Crystal and Reference Clock Requirements
4.3.8.1 Crystal and Reference Clock Requirements: 24 or 48 MHz

Description	Minimum	Typical	Maximum
Crystal frequency	N/A	24 or 48 MHz only	N/A
Crystal accuracy			± 30 PPM
Cycle-to-cycle jitter			± 200 ps
Long-term jitter			± 500 ps

Table 4-13. Jitter Specifications (24 or 48 MHz).

4.3.8.2 Crystal and Reference Clock Requirements: 32.768 KHz

Description	Minimum	Typical	Maximum
Crystal accuracy			± 30 PPM

Table 4-14. Jitter Specifications (32.768 KHz).
4.4 Electrical: Fail-Safe Pins

The A12A35 chip provides a number of fail-safe CMOS pins that can have active signals at or below 3.6 V when the A12A35 is powered down. For fail-safe pin locations, please refer to [Chapter 7](#).

Pin Name	Multiplexed Function					
	First	Second	Third	Fourth	Fifth	GPIO
GPIO_0	sd_hs_sel					0
GPIO_1	ehci_app_prt_ovcurr0	uart_ahb_rx	ssis_sclk	sc_c0		1
GPIO_2	ehci_app_prt_ovcurr1	uart_ahb_tx	ssis_rxd	sc_c1		2
GPIO_3	ehci_prt_pwr_0	uart_ahb_cts_n	ssis_txd	sc_c2		3
GPIO_4	ehci_prt_pwr_1	uart_ahb_rts_n	ssis_en	sc_c3		4
GPIO_5	pwm_1	idsp_pip_iopad_master_hsync	vin_strig0	sc_d0	uart_ahb_cts_n	5
GPIO_6	pwm_2	idsp_pip_iopad_master_vsync	vin_strig1	sc_d1	uart_ahb_rts_n	6
SC_A0	sc_a0	ssi1_sclk	norspi_clk	pwm_0	sdxc_cmd	7
SC_A1	sc_a1	ssi1_txd	norspi_dq[0]	pwm_1	sdxc_cd	8
SC_A2	sc_a2	ssi1_rxd	norspi_dq[1]	pwm_2	sdxc_wp	9
SC_A3	sc_a3	ssi1_en0	norspi_dq[2]	pwm_3	sdxc_d[0]	10
SC_B0	sc_b0	ssi1_en1	norspi_dq[3]		sdxc_d[1]	11
SC_B1	sc_b1	ssi1_en2	norspi_en[0]	norspi_dq[2]	sdxc_d[2]	12
SC_B2	sc_b2	ssi1_en3	norspi_en[1]	norspi_dq[3]	sdxc_d[3]	13
SC_B3	sc_b3	pwm_3	norspi_en[2]		sdxc_d[4]	14
SC_C0	sc_c0	uart_ahb_rx	ssis_sclk		sdxc_d[5]	15
SC_C1	sc_c1	uart_ahb_tx	ssis_rxd	enet_crs	sdxc_d[6]	16
SC_C2	sc_c2	uart_ahb_cts_n	ssis_txd	enet_rxd_2	sdxc_d[7]	17
SC_C3	sc_c3	uart_ahb_rts_n	ssis_en	enet_rxd_3	sdxc_clk	18
SC_D0	sc_d0	uart_ahb_rx	ssis_sclk	enet_col	pwm_0	19
SC_D1	sc_d1	uart_ahb_tx	ssis_rxd	enet_tx_clk	pwm_1	20
SC_D2	sc_d2	uart_ahb_cts_n	ssis_txd	enet_tx_er	pwm_2	21
SC_D3	sc_d3	uart_ahb_rts_n	ssis_en	enet_txd_2	pwm_3	22
SC_E0	sc_e0	ssi0_en2	norspi_en[3]	enet_txd_3	pwm_1	23
TIMER0	tm11_clk			enet_2nd_ref_clk		24
TIMER1	tm12_clk		idsp_pip_iopad_master_hsync	enet_mdc		25
TIMER2	tm13_clk	ssi0_en3	idsp_pip_iopad_master_vsync	enet_mdio		26



Pin Name	Multiplexed Function					
	First	Second	Third	Fourth	Fifth	GPIO
IDCCLK	idc0clk					27
IDCDATA	idc0data					28
IDC2CLK	idc1clk		norspi_dq[2]	norspi_en[2]		29
IDC2DATA	idc1data		norspi_dq[3]	norspi_en[3]		30
IDC3CLK	idc2clk	vin_strig0				31
IDC3DATA	idc2data	vin_strig1				32
IR_IN	ir_in					33
SSIOCLK	ssi0_sclk	norspi_clk	uart_ahb_rx	ssis_sclk		34
SSIOMOSI	ssi0_txd	norspi_dq[0]	uart_ahb_tx	ssis_rxd		35
SSIOMISO	ssi0_rxd	norspi_dq[1]	uart_ahb_cts_n	ssis_txd		36
SSIOEN0	ssi0_en0	norspi_en[0]	uart_ahb_rts_n	ssis_en		37
SSIOEN1	ssi0_en1	norspi_en[1]				38
UARTORX	uart0rx	uart_ahb_rx				39
UARTOTX	uart0tx	uart_ahb_tx				40
I2S_CLK	i2s_clk					41
I2S_SI	i2s_si					42
I2S_SO	i2s_so					43
I2S_WS	i2s_ws					44
CLK_AU						45
WP		nand_wp				54
SMIO_0		nand_ce	norspi_clk			55
SMIO_2		sd_clk				57
SMIO_3		sd_cmd				58
SMIO_4		sd_cd				59
SMIO_5		sd_wp				60
SMIO_18		sd_d[0]				73
SMIO_19		sd_d[1]				74
SMIO_20		sd_d[2]				75
SMIO_21		sd_d[3]				76
SMIO_22		sd_d[4]		sc_c0	ssis_sclk	77
SMIO_23		sd_d[5]		sc_c1	ssis_rxd	78
SMIO_24		sd_d[6]		sc_c2	ssis_txd	79
SMIO_25		sd_d[7]		sc_c3	ssis_en	80
SMIO_26		sdio_clk				81
SMIO_27		sdio_cmd				82
SMIO_28		sdio_d[0]		sc_d0	ssis_sclk	83
SMIO_29		sdio_d[1]		sc_d1	ssis_rxd	84
SMIO_30		sdio_d[2]		sc_d2	ssis_txd	85
SMIO_31		sdio_d[3]		sc_d3	ssis_en	86
SMIO_32		sdio_cd				87
SMIO_33		sdio_wp				88
HPD	hdmitx_hpd					89
CEC	hdmitx_cec	enet_2nd_ref_clk				90
SVSYNC	vin_svsync	idsp_pip_iopad_master_hsync				91

Pin Name	Multiplexed Function					
	First	Second	Third	Fourth	Fifth	GPIO
SHSYNC	vin_shsync	idsp_pip_iopad_ master_vsync				92
VDO_CLK	vd0_clk					109
VD_PWM	pwm_0					113
DETECT_VBUS						
JTAG_TDO						

Table 4-15. Fail-Safe Pins Which Can Have Active Signals At or Below 3.6 V When the A12A35 is Powered Down.

Confidential
For FORWARD Only

4.5 Electrical: Video Signal Wave Forms and Timing

4.5.1 Video Waveform: Video Input (VIN) LVCMOS Timing

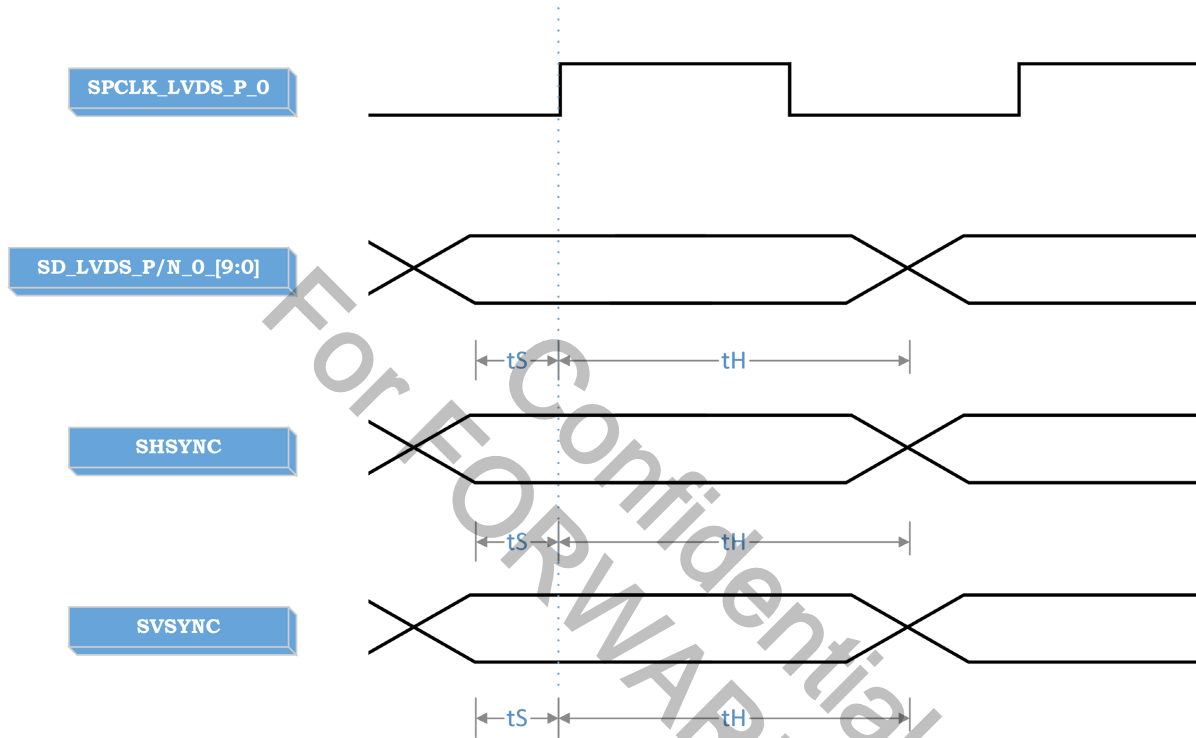

Figure 4-1. Video Input (VIN) LVCMOS Timing.

Parameter	Setup (tS)	Hold (tH)	Comment
Data: SD_LVDS_P/N_0 [9:0]	2 ns	2 ns	Assume the rising edge of the pixel clock SPCLK_LVDS_P_0 is used to latch the data.
HSync: SHSYNC	2 ns	2 ns	
VSync: SVSYNC	2 ns	2 ns	
SField: (See Section 2.3)	2 ns	2 ns	

Table 4-16. LVCMOS Video Input Timing Setup/Hold With Respect to **SPCLK_LVDS_P/N [N]**.

4.5.2 Video Waveform: Video Input (VIN) SLVS/MIPI Timing

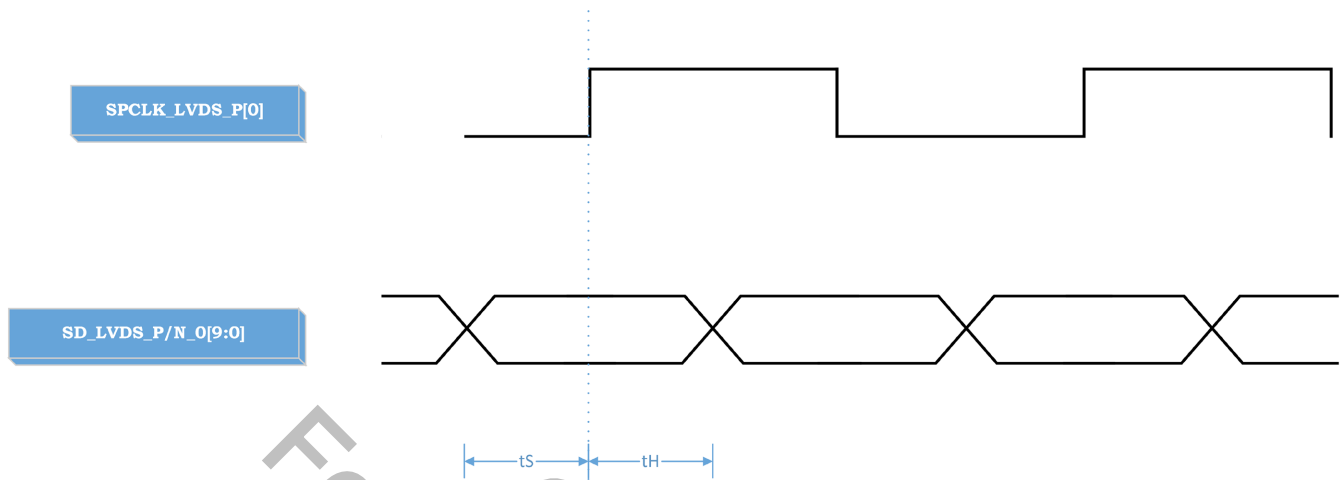

Figure 4-2. Video Input (VIN) SLVS/MIPI Timing.

Parameter	Setup (tS)	Hold (tH)	Comment
Data: SD_LVDS_P/N_0_[9:0]	150 ps	150 ps	Assume the rising edge of the pixel clock SPCLK_LVDS_P[0] is used to latch the data.

Table 4-17. SLVS/MIPI Video Input Timing Setup/Hold With Respect to **SPCLK_LVDS_P/N_[N]**.

4.5.3 Video Waveform: Video Output (VOUT) Timing

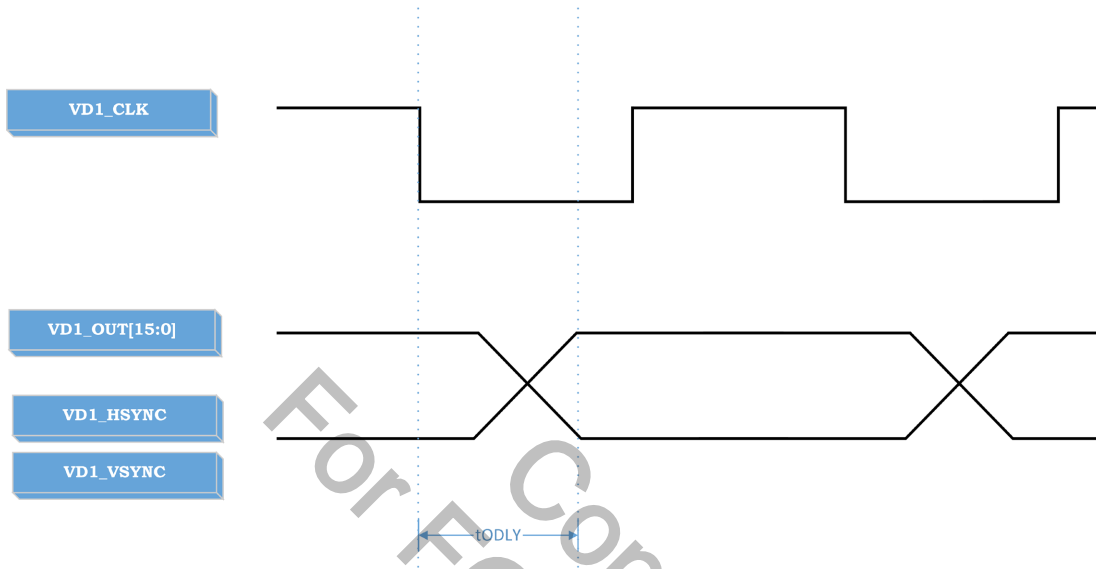

Figure 4-3. Video Output Timing.

Parameter	Minimum	Typical	Maximum	Comment
VD1_CLK Frequency		Resolution Dependent		Assume the data is latched out at the falling edge of VD1_CLK .
VD1_CLK Duty	40%	50%	60%	
tODLY Output Delay	-2 ns		2 ns	

Table 4-18. Video Output Timing Setup/Hold With Respect to **VD1_CLK**.

4.6 Electrical: SD Controller Timing

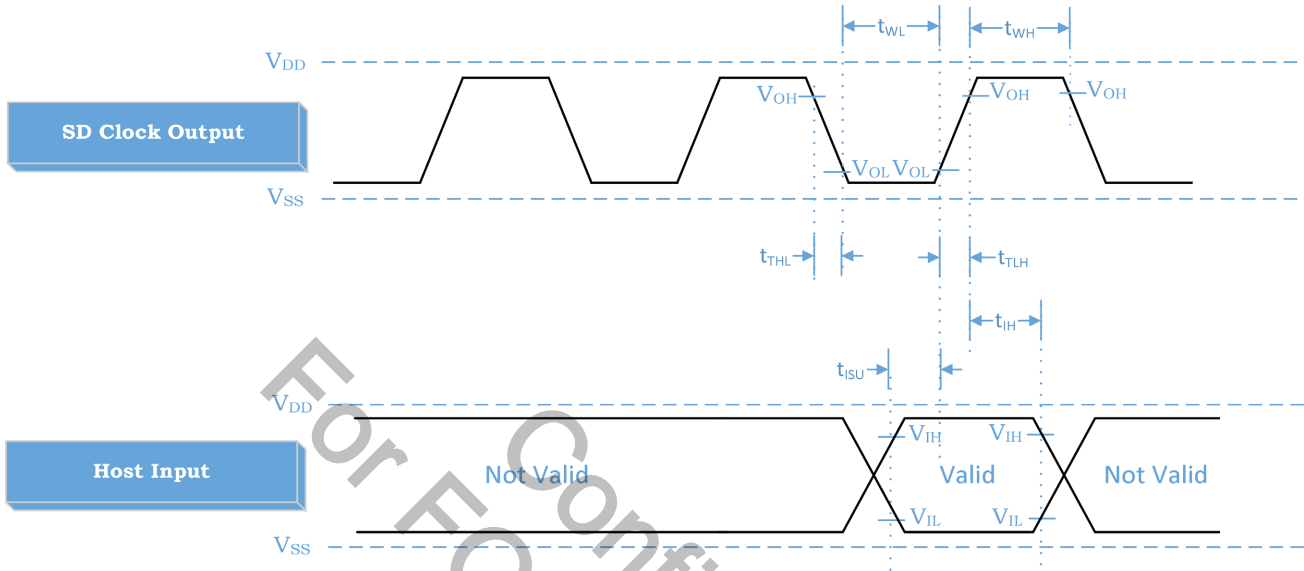

Figure 4-4. SD Host Input Timing.

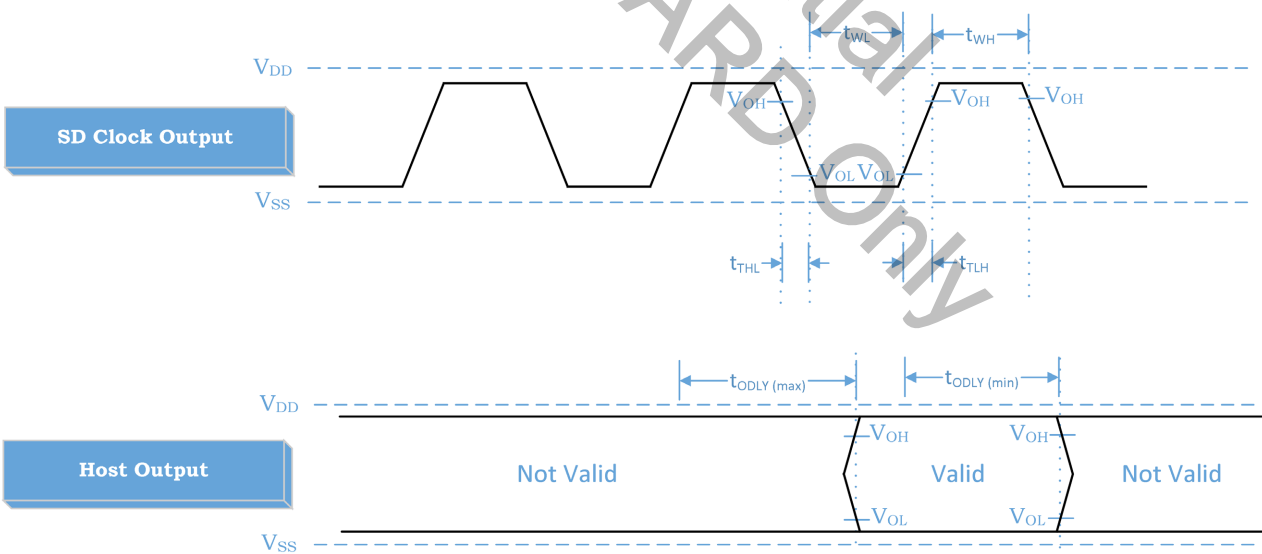

Figure 4-5. SD Host Output Timing.

Parameter	Symbol	Min	Max	Unit	Comment
Clock CLK: All values are referred to as min (VIH) and max (VIL)					
Clock Frequency: Data Transfer Mode	f_{PP}	0	48	MHz	$C_{CARD} \leq 10 \text{ pF}$ (1 Card)
Clock Frequency: Identification Mode	f_{OD}	0/100	400	kHz	$C_{CARD} \leq 10 \text{ pF}$ (1 Card)
Clock Low Time	t_{WL}	7		ns	$C_{CARD} \leq 10 \text{ pF}$ (1 Card)
Clock High Time	t_{WH}	7		ns	$C_{CARD} \leq 10 \text{ pF}$ (1 Card)
Clock Rise Time	t_{TLH}		3	ns	$C_{CARD} \leq 10 \text{ pF}$ (1 Card)
Clock Fall Time	t_{THL}		3	ns	$C_{CARD} \leq 10 \text{ pF}$ (1 Card)
Inputs CMD, DAT: Referenced to CLK					
Input Set-Up Time	t_{ISU}	5.83		ns	$C_{CARD} \leq 10 \text{ pF}$ (1 Card)
Input Hold Time	t_{IH}	1.5		ns	$C_{CARD} \leq 10 \text{ pF}$ (1 Card)
Outputs CMD, DAT: Referenced to CLK at 48 MHz					
Output Delay Time	t_{ODLY}	8.85	12.16	ns	$C_L \leq 40 \text{ pF}$ (1 Card)

Table 4-19. SD Controller Timing Parameters.

4.7 Electrical: eMMC Boot Timing

To successfully boot from eMMC, the eMMC device should return boot data with the following timing constraints.

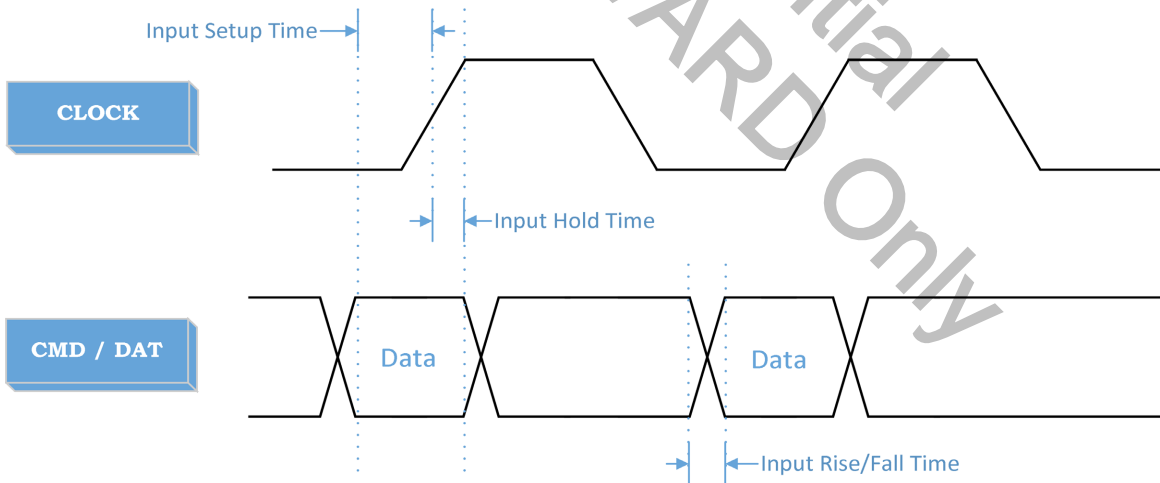

Figure 4-6. eMMC Boot Timing Diagram.

Parameter	Minimum	Maximum
Host CMD / DAT Input Timing		
Input Setup Time	5.83 ns	
Input Hold Time	1.5 ns	
Signal Rise Time		3 ns
Signal Fall Time		3 ns

Table 4-20. eMMC Boot Timing.

Note:

1. CMD / DAT input rise and fall time are measured by VIL and VIH.

FOR FORWARD Only

5. PACKAGE

The A12A35 chip has a 404-pin TFBGA package (15 mm x 15 mm).

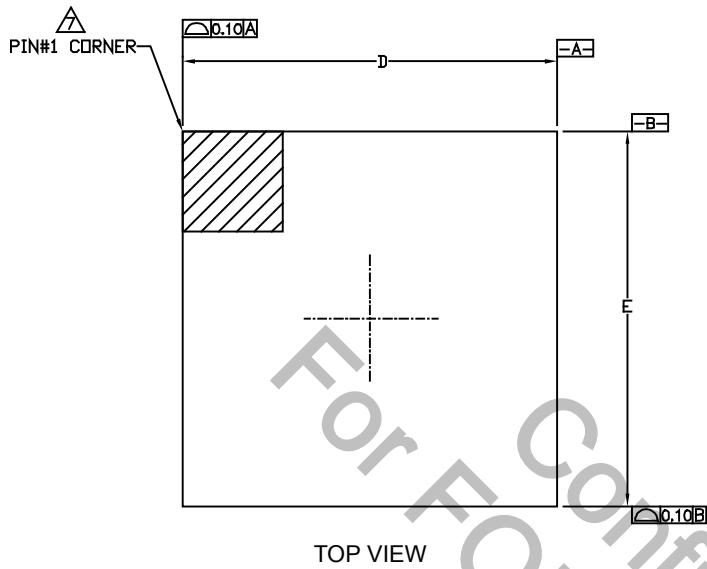

Figure 5-1. Top View of the A12A35 Package.

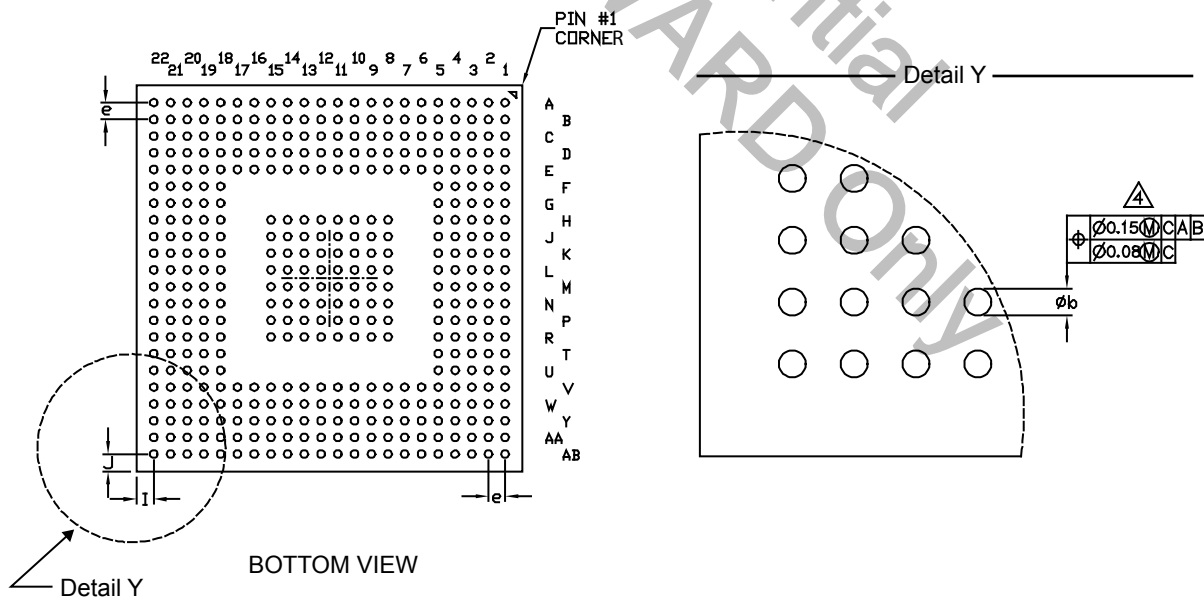

Figure 5-2. Bottom View of the A12A35 Package (left) with Detail Y (right).

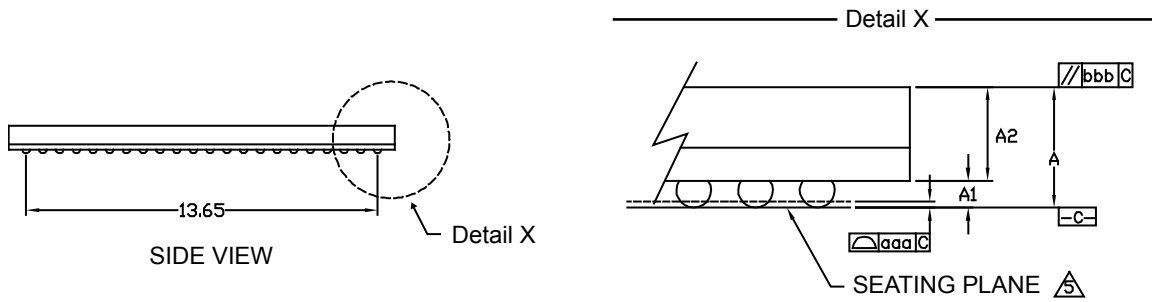

Figure 5-3. Side View of the A12A35 Package (left) with Detail X (right).

Dimension	Minimum	Nominal	Maximum
A			1.30
A1	0.18	0.23	0.28
A2	0.86	0.91	0.94
D	14.90	15.00	15.10
E	14.90	15.00	15.10
I		0.675 rEF.	
J		0.675 rEF.	
M		22 x 22 <Depopulated>	
aaa			0.10
bbb			0.10
b	0.25	0.30	0.35
e		0.65 TYP.	
Number of Balls: 404			

Table 5-1. Dimensions of the A12A35 Package (millimeters).

Notes for table and figures:

1. All dimensions are in millimeters.
2. Basic solder ball grid pitch (e).
3. Maximum solder ball grid size (M).
4. A1 corner must be delineated by ink or laser mark.
5. Package total height (A) tolerance must be in 1.14/+0.06 - 0.1 mm.

6. CONTACT AND ORDER INFORMATION

All chips in the A12 series are Lead-Free, Halogen-Free and RoHS compliant.

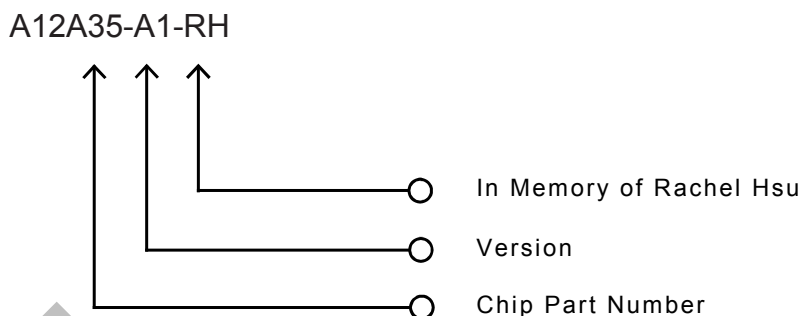

US

3101 Jay St.
 Ste. 110
 Santa Clara, CA 95054, USA
 Phone: +1.408.734.8888
 Fax: +1.408.734.0788

Korea

6 Floor, Hanwon-Bldg.
 Sunae-Dong, 6-1, Bundang-Gu
 SeongNam-City, Kyunggi-Do
 Republic of Korea 463-825
 Phone: +031.717.2780
 Fax: +031.717.2782

Hong Kong

Unit A&B, 18/F, Spectrum Tower
 53 Hung To Road
 Kwun Tong, Kowloon
 Phone: +85.2.2806.8711
 Fax: +85.2.2806.8722

China - Shanghai

9th Floor, Park Center
 1088 Fangdian Road, Pudong New District
 Shanghai 201204, China
 Phone: +86.21.6088.0608
 Fax: +86.21.6088.0366

Taiwan

Suite C1, No. 1, Li-Hsin Road 1
 Science-Based Industrial Park
 Hsinchu 30078, Taiwan
 Phone: +886.3.666.8828
 Fax: +886.3.666.1282

Japan - Yokohama

Shin-Yokohama Business Center Bldg. 5th Floor
 3-2-6 Shin-Yokohama, Kohoku-ku,
 Yokohama, Kanagawa, 222-0033, Japan
 Phone: +81.45.548.6150
 Fax: +81.45.548.6151

China - Shenzhen

Unit E, 5th Floor
 No. 2 Finance Base
 8 Ke Fa Road
 Shenzhen, 518057, China
 Phone: +86.755.3301.0366
 Fax: +86.755.3301.0966

7. PIN LIST AND MAPPING TABLE

This section provides a list of the 404 external pins according to their location on the A12A35 chip. Figure 7-1 below indicates the orientation of the pins by column (numbers) and row (letters).

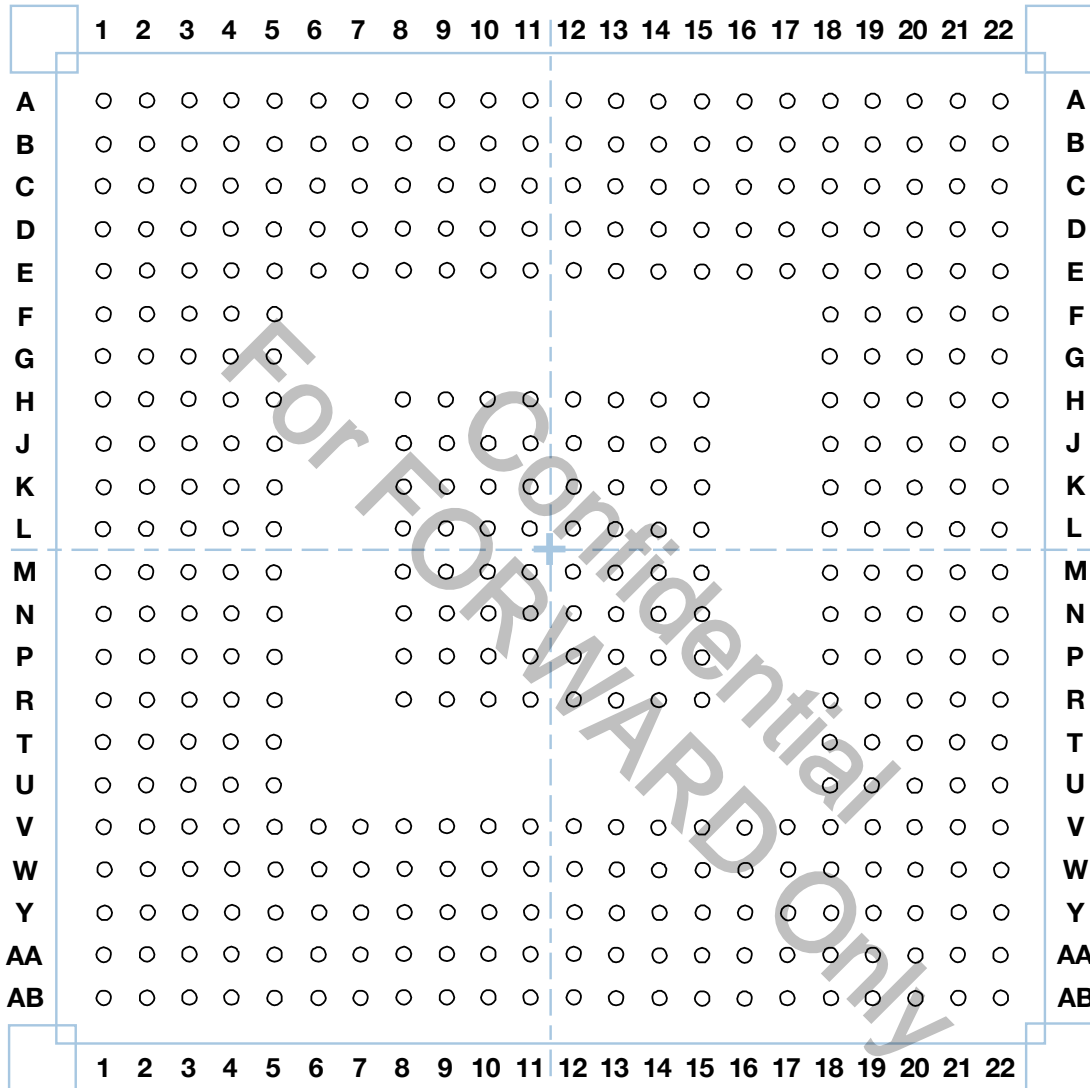

Figure 7-1. Pin Map for the A12A35 Chip.

The table below lists all of the external pins on the A12A35 chip in alphabetic order by map location. Each entry provides the pin name as it appears on the ball map, the location of the pin on the map and on schematics, the functional group, and multiplexed functionality detail if applicable.

Loc.	Pin Name	Group	Type	Multiplexed Functions					
				First	Second	Third	Fourth	Fifth	GPIO
A1	PWC_PC_REF	PWC	Analog						
A2	XO_RTC	Global	Analog						
A3	PWC_RTC_CP	PWC	CMOS						

Loc.	Pin Name	Group	Type	Multiplexed Functions					
				First	Second	Third	Fourth	Fifth	GPIO
A4	PWC_PC_VDD	Power	Supply						
A5	PWC_RSTOB	PWC	Analog						
A6	DDR_CALIBR	DDR2/3	Analog						
A7	DDR_DQ_25	DDR2/3	SSTL18						
A8	DDR_DQS_BAR_3	DDR2/3	SSTL18						
A9	DDR_VREF_3	Power	DDR HOST Supply						
A10	DDR_DQ_19	DDR2/3	SSTL18						
A11	DDR_DQS_BAR_2	DDR2/3	SSTL18						
A12	DDR_DM_1	DDR2/3	SSTL18						
A13	DDR_DQS_BAR_1	DDR2/3	SSTL18						
A14	DDR_DQ_11	DDR2/3	SSTL18						
A15	DDR_VREF_2	Power	DDR HOST Supply						
A16	DDR_DQS_BAR_0	DDR2/3	SSTL18						
A17	DDR_DQ_3	DDR2/3	SSTL18						
A18	DDR_CK_BAR	DDR2/3	SSTL18						
A19	DDR_CKE	DDR2/3	SSTL18						
A20	DDR_CK_2_BAR	DDR2/3	SSTL18						
A21	DDR_ADDR_6	DDR2/3	SSTL18						
A22	DDR_ADDR_8	DDR2/3	SSTL18						
B1	JTAG_TDI	JTAG	CMOS						
B2	XI_RTC	Global	Analog						
B3	ADC_CH_2	ADC	Analog						
B4	ADC_CH_0	ADC	Analog						
B5	PWC_RSTINB	PWC	Analog						
B6	DDR_DQ_29	DDR2/3	SSTL18						
B7	DDR_DQ_26	DDR2/3	SSTL18						
B8	DDR_DQS_3	DDR2/3	SSTL18						
B9	DDR_DM_3	DDR2/3	SSTL18						
B10	DDR_DQ_18	DDR2/3	SSTL18						
B11	DDR_DQS_2	DDR2/3	SSTL18						
B12	DDR_DQ_15	DDR2/3	SSTL18						
B13	DDR_DQS_1	DDR2/3	SSTL18						
B14	DDR_DQ_10	DDR2/3	SSTL18						
B15	DDR_DM_0	DDR2/3	SSTL18						
B16	DDR_DQS_0	DDR2/3	SSTL18						
B17	DDR_DQ_2	DDR2/3	SSTL18						
B18	DDR_CK	DDR2/3	SSTL18						
B19	DDR_ADDR_10	DDR2/3	SSTL18						
B20	DDR_CK_2	DDR2/3	SSTL18						
B21	DDR_ADDR_4	DDR2/3	SSTL18						

Loc.	Pin Name	Group	Type	Multiplexed Functions					
				First	Second	Third	Fourth	Fifth	GPIO
B22	DDR_ADDR_11	DDR2/3	SSTL18						
C1	JTAG_CLK	JTAG	CMOS						
C2	JTAG_TMS	JTAG	CMOS						
C3	ADC_CH_3	ADC	Analog						
C4	ADC_CH_1	ADC	Analog						
C5	PWC_PSEQ2	PWC	Analog						
C6	DDR_DQ_30	DDR2/3	SSTL18						
C7	DDR_DQ_27	DDR2/3	SSTL18						
C8	DDR_DQ_22	DDR2/3	SSTL18						
C9	DDR_DQ_17	DDR2/3	SSTL18						
C10	DDR_DM_2	DDR2/3	SSTL18						
C11	DDR_DQ_20	DDR2/3	SSTL18						
C12	DDR_DQ_14	DDR2/3	SSTL18						
C13	DDR_DQ_13	DDR2/3	SSTL18						
C14	DDR_DQ_9	DDR2/3	SSTL18						
C15	DDR_DQ_7	DDR2/3	SSTL18						
C16	DDR_DQ_5	DDR2/3	SSTL18						
C17	DDR_DQ_1	DDR2/3	SSTL18						
C18	DDR_CAS	DDR2/3	SSTL18						
C19	DDR_WE	DDR2/3	SSTL18						
C20	DDR_BA_1	DDR2/3	SSTL18						
C21	DDR_ADDR_1	DDR2/3	SSTL18						
C22	DDR_ADDR_14	DDR2/3	SSTL18						
D1	JTAG_TDO	JTAG	CMOS						
D2	JTAG_RST_L	JTAG	CMOS						
D3	ADC_VSSA	Power	Analog Ground						
D4	PWC_PSEQ3	PWC	Analog						
D5	PWC_PSEQ1	PWC	Analog						
D6	DDR_DQ_31	DDR2/3	SSTL18						
D7	DDR_DQ_28	DDR2/3	SSTL18						
D8	DDR_DQ_24	DDR2/3	SSTL18						
D9	DDR_DQ_21	DDR2/3	SSTL18						
D10	DDR_DQ_23	DDR2/3	SSTL18						
D11	DDR_DQ_16	DDR2/3	SSTL18						
D12	DDR_VDDQ_D12	Power	DDR HOST Supply						
D13	DDR_DQ_12	DDR2/3	SSTL18						
D14	DDR_DQ_8	DDR2/3	SSTL18						
D15	DDR_DQ_6	DDR2/3	SSTL18						
D16	DDR_DQ_4	DDR2/3	SSTL18						
D17	DDR_DQ_0	DDR2/3	SSTL18						
D18	DDR_RAS	DDR2/3	SSTL18						
D19	DDR_BA_0	DDR2/3	SSTL18						
D20	DDR_CS_2	DDR2/3	SSTL18						
D21	DDR_ADDR_2	DDR2/3	SSTL18						



Loc.	Pin Name	Group	Type	Multiplexed Functions					
				First	Second	Third	Fourth	Fifth	GPIO
D22	DDR_ADDR_9	DDR2/3	SSTL18						
E1	DAC_COMP	DAC	Analog						
E2	DAC_VREFIN	DAC	Analog						
E3	VDAC_VSSA	Power	Analog Ground						
E4	VDAC_VDDA18	Power	Analog Supply						
E5	ADC_VDDA18	Power	Analog Supply						
E6	VSS_E6	Power	Ground						
E7	VSS_E7	Power	Ground						
E8	VSS_E8	Power	Ground						
E9	DDR_VDDQ_E9	Power	DDR HOST Supply						
E10	DDR_VDDQ_E10	Power	DDR HOST Supply						
E11	DDR_VDDQ_E11	Power	DDR HOST Supply						
E12	DDR_VDDQ_E12	Power	DDR HOST Supply						
E13	DDR_VDDQ_E13	Power	DDR HOST Supply						
E14	DDR_VDDQ_E14	Power	DDR HOST Supply						
E15	DDR_VDDQ_E15	Power	DDR HOST Supply						
E16	VSS_E16	Power	Ground						
E17	VSS_E17	Power	Ground						
E18	VSS_E18	Power	Ground						
E19	DDR_ADDR_15	DDR2/3	SSTL18						
E20	DDR_ADDR_12	DDR2/3	SSTL18						
E21	DDR_ADDR_0	DDR2/3	SSTL18						
E22	DDR_ADDR_13	DDR2/3	SSTL18						
F1	DAC_IO	DAC	Analog						
F2	VDAC_VDDA33	Power	Analog Supply						
F3	ADC_VDDA33	Power	Analog Supply						
F4	PWC_WKUP1	PWC	Analog						
F5	PWC_WKUP	PWC	Analog						
F18	VSS_F18	Power	Ground						



Loc.	Pin Name	Group	Type	Multiplexed Functions					
				First	Second	Third	Fourth	Fifth	GPIO
F19	DDR_CS	DDR2/3	SSTL18						
F20	DDR_BA_2	DDR2/3	SSTL18						
F21	DDR_ADDR_5	DDR2/3	SSTL18						
F22	DDR_ADDR_7	DDR2/3	SSTL18						
G1	DAC_RSET	DAC	Analog						
G2	GPIO_2	GPIO	CMOS	ehci_app_prt_ovcurr1	uart_ahb_tx	ssis_rxd	sc_c1		2
G3	GPIO_4	GPIO	CMOS	ehci_prt_pwr_1	uart_ahb_rts_n	ssis_en	sc_c3		4
G4	GPIO_5	GPIO	CMOS	pwm_1	idsp_pip_io-pad_master_hsync	vin_strig0	sc_d0	uart_ahb_cts_n	5
G5	VDDA18_PLL	Power	Analog Supply						
G18	VSS_G18	Power	Ground						
G19	DDR_ODT	DDR2/3	SSTL18						
G20	DDR_VDDQ_CKE	DDR2/3	SSTL18	Tied to Internal DDR_CK-EIN					
G21	DDR_ADDR_3	DDR2/3	SSTL18						
G22	DDR_RESET	DDR2/3	SSTL18						
H1	XIN	Global	XOSC						
H2	GPIO_1	GPIO	CMOS	ehci_app_prt_ovcurr0	uart_ahb_rx	ssis_sclk	sc_c0		1
H3	GPIO_3	GPIO	CMOS	ehci_prt_pwr_0	uart_ahb_cts_n	ssis_txd	sc_c2		3
H4	GPIO_6	GPIO	CMOS	pwm_2	idsp_pip_io-pad_master_vsync	vin_strig1	sc_d1	uart_ahb_rts_n	6
H5	PLL_VSSA_H5	Power	Analog Ground						
H8	DDR_VDDQ_H8	Power	DDR HOST Supply						
H9	DDR_VDDQ_H9	Power	DDR HOST Supply						
H10	DDR_VDDQ_H10	Power	DDR HOST Supply						
H11	DDR_VDDQ_H11	Power	DDR HOST Supply						
H12	DDR_VDDQ_H12	Power	DDR HOST Supply						



Loc.	Pin Name	Group	Type	Multiplexed Functions					
				First	Second	Third	Fourth	Fifth	GPIO
H13	DDR_VDDQ_H13	Power	DDR HOST Supply						
H14	DDR_VDDQ_H14	Power	DDR HOST Supply						
H15	DDR_VDDQ_H15	Power	DDR HOST Supply						
H18	NAND_VDDO_H18	Power	Digital Supply						
H19	NAND_VDDO_H19	Power	Digital Supply						
H20	SMIO_25	SMIO	CMOS		sd_d[7]		sc_c3	ssis_en	80
H21	SMIO_21	SMIO	CMOS		sd_d[3]				76
H22	SMIO_2	SMIO	CMOS		sd_clk				57
J1	XOUT	Global	XOSC						
J2	GPIO_0	GPIO	CMOS	sd_hs_sel					0
J3	HDMI_VSSA_J3	Power	Analog Ground						
J4	HDMI_VDDA_J4	Power	Analog Supply						
J5	PLL_VSSA_J5	Power	Analog Ground						
J8	VSS_J8	Power	Ground						
J9	VSS_J9	Power	Ground						
J10	VSS_J10	Power	Ground						
J11	VSS_J11	Power	Ground						
J12	VSS_J12	Power	Ground						
J13	VSS_J13	Power	Ground						
J14	VSS_J14	Power	Ground						
J15	VSS_J15	Power	Ground						
J18	SDIO_VDDO_J18	Power	Digital Supply						
J19	SDIO_VDDO_J19	Power	Digital Supply						
J20	SMIO_22	SMIO	CMOS		sd_d[4]		sc_c0	ssis_sclk	77
J21	SMIO_20	SMIO	CMOS		sd_d[2]				75
J22	SMIO_3	SMIO	CMOS		sd_cmd				58
K1	HDMI_REXT	HDMI	Analog						
K2	HPD	HDMI	CMOS	hdmitx_hpd					89
K3	HDMI_VSSA_K3	Power	Analog Ground						
K4	HDMI_VDDA	Power	Analog Supply						
K5	VDDA10_PLL_K5	Power	Analog Supply						



Loc.	Pin Name	Group	Type	Multiplexed Functions					
				First	Second	Third	Fourth	Fifth	GPIO
K8	VSS_K8	Power	Ground						
K9	VSS_K9	Power	Ground						
K10	VSS_K10	Power	Ground						
K11	VSS_K11	Power	Ground						
K12	VSS_K12	Power	Ground						
K13	VSS_K13	Power	Ground						
K14	VSS_K14	Power	Ground						
K15	VSS_K15	Power	Ground						
K18	VDD33_K18	Power	Digital Supply						
K19	FSOURCE_0	Global	Supply/ Ground						
K20	SMIO_23	SMIO	CMOS		sd_d[5]		sc_c1	ssis_rxd	78
K21	SMIO_19	SMIO	CMOS		sd_d[1]				74
K22	SMIO_5	SMIO	CMOS		sd_wp				60
L1	HDMI_CLK_P	HDMI	Analog						
L2	HDMI_CLK_M	HDMI	Analog						
L3	HDMI_AVDD25	Power	Analog Supply						
L4	HDMI_AVDDFLESD	Power	Analog Supply						
L5	VDDA10_PLL_L5	Power	Analog Supply						
L8	VSS_L8	Power	Ground						
L9	VSS_L9	Power	Ground						
L10	VSS_L10	Power	Ground						
L11	VSS_L11	Power	Ground						
L12	VSS_L12	Power	Ground						
L13	VSS_L13	Power	Ground						
L14	VSS_L14	Power	Ground						
L15	VSS_L15	Power	Ground						
L18	VDD33_L18	Power	Digital Supply						
L19	SMIO_24	SMIO	CMOS		sd_d[6]		sc_c2	ssis_txd	79
L20	SMIO_13	SMIO	CMOS		nand_d[4]	norspi_dq[0]			68
L21	SMIO_14	SMIO	CMOS		nand_d[5]	norspi_dq[1]			69
L22	SMIO_15	SMIO	CMOS		nand_d[6]	norspi_dq[2]			70
M1	HDMI_CHO_P	HDMI	Analog						
M2	HDMI_CHO_M	HDMI	Analog						
M3	HDMI_VDD10_M3	Power	Digital Supply						
M4	HDMI_VDD10_M4	Power	Digital Supply						
M5	CLK_AU	GPIO	CMOS						45
M8	VSS_M8	Power	Ground						
M9	VDD_M9	Power	Digital Supply						



A12A35 Chip Datasheet - Preliminary

Loc.	Pin Name	Group	Type	Multiplexed Functions					
				First	Second	Third	Fourth	Fifth	GPIO
M10	VDD_M10	Power	Digital Supply						
M11	VDD_M11	Power	Digital Supply						
M12	VDD_M12	Power	Digital Supply						
M13	VDD_M13	Power	Digital Supply						
M14	VDD_M14	Power	Digital Supply						
M15	VSS_M15	Power	Ground						
M18	SD_VDDO_M18	Power	Digital Supply						
M19	SMIO_26	SMIO	CMOS		sdio_clk				81
M20	SMIO_12	SMIO	CMOS		nand_d[3]	norspi_en[3]			67
M21	SMIO_10	SMIO	CMOS		nand_d[1]	norspi_en[1]			65
M22	SMIO_4	SMIO	CMOS		sd_cd				59
N1	HDMI_CH1_P	HDMI	Analog						
N2	HDMI_CH1_M	HDMI	Analog						
N3	SC_A0	GPIO	CMOS	sc_a0	ssi1_sclk	norspi_clk	pwm_0	sdxc_cmd	7
N4	SC_A1	GPIO	CMOS	sc_a1	ssi1_txd	norspi_dq[0]	pwm_1	sdxc_cd	8
N5	CLK_SI	Sensor	CMOS						
N8	VSS_N8	Power	Ground						
N9	VDD_N9	Power	Digital Supply						
N10	VDD_N10	Power	Digital Supply						
N11	VDD_N11	Power	Digital Supply						
N12	VDD_N12	Power	Digital Supply						
N13	VDD_N13	Power	Digital Supply						
N14	VDD_N14	Power	Digital Supply						
N15	VSS_N15	Power	Ground						
N18	SD_VDDO_N18	Power	Digital Supply						
N19	SMIO_27	SMIO	CMOS		sdio_cmd				82
N20	SMIO_11	SMIO	CMOS		nand_d[2]	norspi_en[2]			66
N21	SMIO_9	SMIO	CMOS		nand_d[0]	norspi_en[0]			64
N22	SMIO_1	SMIO	CMOS		nand_rb	norspi_dq[4]			56
P1	HDMI_CH2_P	HDMI	Analog						
P2	HDMI_CH2_M	HDMI	Analog						
P3	SC_A2	GPIO	CMOS	sc_a2	ssi1_rxd	norspi_dq[1]	pwm_2	sdxc_wp	9
P4	SC_A3	GPIO	CMOS	sc_a3	ssi1_en0	norspi_dq[2]	pwm_3	sdxc_d[0]	10
P5	SC_B0	GPIO	CMOS	sc_b0	ssi1_en1	norspi_dq[3]		sdxc_d[1]	11
P8	VSS_P8	Power	Ground						



Loc.	Pin Name	Group	Type	Multiplexed Functions					
				First	Second	Third	Fourth	Fifth	GPIO
P9	VDD_P9	Power	Digital Supply						
P10	VDD_P10	Power	Digital Supply						
P11	VDD_P11	Power	Digital Supply						
P12	VDD_P12	Power	Digital Supply						
P13	VDD_P13	Power	Digital Supply						
P14	VDD_P14	Power	Digital Supply						
P15	VSS_P15	Power	Ground						
P18	VDDP18_P18	Power	Digital Supply						
P19	SMIO_28	SMIO	CMOS		sdio_d[0]		sc_d0	ssis_sclk	83
P20	SMIO_16	SMIO	CMOS		nand_d[7]	norspi_dq[3]			71
P21	SMIO_18	SMIO	CMOS		sd_d[0]				73
P22	SMIO_0	SMIO	CMOS		nand_ce	norspi_clk			55
R1	SC_C1	GPIO	CMOS	sc_c1	uart_ahb_tx	ssis_rxd	enet_crs	sdxc_d[6]	16
R2	SC_C0	GPIO	CMOS	sc_c0	uart_ahb_rx	ssis_sclk		sdxc_d[5]	15
R3	SC_E0	GPIO	CMOS	sc_e0	ssi0_en2	norspi_en[3]	enet_txd_3	pwm_1	23
R4	SC_B2	GPIO	CMOS	sc_b2	ssi1_en3	norspi_en[1]	norspi_dq[3]	sdxc_d[3]	13
R5	SC_B1	GPIO	CMOS	sc_b1	ssi1_en2	norspi_en[0]	norspi_dq[2]	sdxc_d[2]	12
R8	VSS_R8	Power	Ground						
R9	VDD_R9	Power	Digital Supply						
R10	VDD_R10	Power	Digital Supply						
R11	VDD_R11	Power	Digital Supply						
R12	VDD_R12	Power	Digital Supply						
R13	VDD_R13	Power	Digital Supply						
R14	VDD_R14	Power	Digital Supply						
R15	VSS_R15	Power	Ground						
R18	VDDP18_R18	Power	Digital Supply						
R19	SMIO_29	SMIO	CMOS		sdio_d[1]		sc_d1	ssis_rxd	84
R20	SMIO_17	SMIO	CMOS		nand_cle				72
R21	SMIO_7	SMIO	CMOS		nand_we	norspi_dq[6]			62
R22	SMIO_6	SMIO	CMOS		nand_re	norspi_dq[5]			61
T1	SC_C2	GPIO	CMOS	sc_c2	uart_ahb_cts_n	ssis_txd	enet_rxd_2	sdxc_d[7]	17

Loc.	Pin Name	Group	Type	Multiplexed Functions					
				First	Second	Third	Fourth	Fifth	GPIO
T2	SC_C3	GPIO	CMOS	sc_c3	uart_ahb_rts_n	ssis_en	enet_rxd_3	sdxc_clk	18
T3	SC_D0	GPIO	CMOS	sc_d0	uart_ahb_rx	ssis_sclk	enet_col	pwm_0	19
T4	SC_D1	GPIO	CMOS	sc_d1	uart_ahb_tx	ssis_rxd	enet_tx_clk	pwm_1	20
T5	SC_B3	GPIO	CMOS	sc_b3	pwm_3	norspi_en[2]		sdxc_d[4]	14
T18	VDDP18_T18	Power	Digital Supply						
T19	SMIO_33	SMIO	CMOS		sdio_wp				88
T20	SMIO_8	SMIO	CMOS		nand_ale	norspi_dq[7]			63
T21	SMIO_31	SMIO	CMOS		sdio_d[3]		sc_d3	ssis_en	86
T22	SMIO_30	SMIO	CMOS		sdio_d[2]		sc_d2	ssis_txd	85
U1	I2S_CLK	I2S	CMOS	i2s_clk					41
U2	TIMER0	GPIO	CMOS	tm11_clk			enet_2nd_ref_clk		24
U3	TIMER2	GPIO	CMOS	tm13_clk	ssi0_en3	idsp_pip_io-pad_master_vsync	enet_mdio		26
U4	SC_D3	GPIO	CMOS	sc_d3	uart_ahb_rts_n	ssis_en	enet_txd_2	pwm_3	22
U5	SC_D2	GPIO	CMOS	sc_d2	uart_ahb_cts_n	ssis_txd	enet_tx_er	pwm_2	21
U18	VD0_OUT_8	VOOUT	CMOS	vd0_out[8]					101
U19	VD0_OUT_0	VOOUT	CMOS	vd0_out[0]					93
U20	SMIO_32	SMIO	CMOS		sdio_cd				87
U21	VD0_OUT_11	VOOUT	CMOS	vd0_out[11]					104
U22	VD0_OUT_15	VOOUT	CMOS	vd0_out[15]					108
V1	I2S_WS	I2S	CMOS	i2s_ws					44
V2	I2S_SO	I2S	CMOS	i2s_so					43
V3	TIMER1	GPIO	CMOS	tm12_clk		idsp_pip_io-pad_master_hsync	enet_mdc		25
V4	IDC3CLK	I2C/IDC	CMOS	idc2clk		vin_strig0			31
V5	WP	GPIO	CMOS		nand_wp				54
V6	IR_IN	IR	CMOS	ir_in					33
V7	UART0RX	GPIO	CMOS	uart0rx	uart_ahb_rx				39
V8	POR_L	Global	CMOS						
V9	LVDS_VDDA11	Power	Analog Supply						
V10	VDDP18_V10	Power	Digital Supply						
V11	VDDP18_V11	Power	Digital Supply						
V12	VDD33_V12	Power	Digital Supply						
V13	VDD33_V13	Power	Digital Supply						



A12A35 Chip Datasheet - Preliminary

Loc.	Pin Name	Group	Type	Multiplexed Functions					
				First	Second	Third	Fourth	Fifth	GPIO
V14	VDD33_V14	Power	Digital Supply						
V15	VDD33_V15	Power	Digital Supply						
V16	VDO_OUT_4	VOOUT	CMOS	vd0_out[4]					97
V17	VDO_OUT_13	VOOUT	CMOS	vd0_out[13]					106
V18	VDO_CLK	VOOUT	CMOS	vd0_clk					109
V19	VDO_OUT_12	VOOUT	CMOS	vd0_out[12]					105
V20	VDO_OUT_7	VOOUT	CMOS	vd0_out[7]					100
V21	VDO_OUT_9	VOOUT	CMOS	vd0_out[9]					102
V22	VDO_HVLD	VOOUT	CMOS	vd0_hvld					112
W1	I2S_SI	I2S	CMOS	i2s_si					42
W2	SSIOMISO	GPIO	CMOS	ssi0_rxd	norspi_dq[1]	uart_ahb_cts_n	ssis_txd		36
W3	IDCDATA	I2C/IDC	CMOS	idc0data					28
W4	IDC3DATA	I2C/IDC	CMOS	idc2data	vin_strig1				32
W5	CEC	HDMI	CMOS	hdmitx_cec	enet_2nd_ref_clk				90
W6	DETECT_VBUS	USB	CMOS						
W7	UART0TX	GPIO	CMOS	uart0tx	uart_ahb_tx				40
W8	LVDS_VDDA18_W8	Power	Analog Supply						
W9	LVDS_VDDA18_W9	Power	Analog Supply						
W10	VDDP18_W10	Power	Digital Supply						
W11	VDDP18_W11	Power	Digital Supply						
W12	VDD33_W12	Power	Digital Supply						
W13	VDD33_W13	Power	Digital Supply						
W14	VDD33_W14	Power	Digital Supply						
W15	VDD33_W15	Power	Digital Supply						
W16	VDO_OUT_2	VOOUT	CMOS	vd0_out[2]					95
W17	VDO_HSYNC	VOOUT	CMOS	vd0_hsync					111
W18	VDO_OUT_1	VOOUT	CMOS	vd0_out[1]					94
W19	VDO_VSYNC	VOOUT	CMOS	vd0_vsync					110
W20	VDO_OUT_10	VOOUT	CMOS	vd0_out[10]					103



Loc.	Pin Name	Group	Type	Multiplexed Functions					
				First	Second	Third	Fourth	Fifth	GPIO
W21	TEST_MODE	Global	CMOS						
W22	VD_PWM	GPIO	CMOS	pwm_0					113
Y1			Reserved						
Y1	SSIOCLK	GPIO	CMOS	ssi0_sclk	norspi_clk	uart_ahb_rx	ssis_sclk		34
Y2	SSIOMOSI	GPIO	CMOS	ssi0_txd	norspi_dq[0]	uart_ahb_tx	ssis_rxd		35
Y3	IDCCLK	I2C/IDC	CMOS	idc0_clk					27
Y4	USB_VDDA33_Y4	Power	Analog Supply						
Y5	USB_VDDA33_Y5	Power	Analog Supply						
Y6	USB1_REXT	USB	Analog						
Y7	USB_VSSA_Y7	Power	Analog Ground						
Y8	USB_VSSA_Y8	Power	Analog Ground						
Y9	LVDS_VSSA_Y9	Power	Analog Ground						
Y10	LVDS_VSSA_Y10	Power	Analog Ground						
Y11	VSS_Y11	Power	Ground						
Y12	VSS_Y12	Power	Ground						
Y13	VSS_Y13	Power	Ground						
Y14	VSS_Y14	Power	Ground						
Y15	SHSYNC	Sensor	CMOS	vin_shsync	idsp_pip_io-pad_master_vsync				92
Y16	SVSYNC	Sensor	CMOS	vin_svsync	idsp_pip_io-pad_master_hsync				91
Y17	VDO_OUT_3	VOOUT	CMOS	vd0_out[3]					96
Y18	VDO_OUT_5	VOOUT	CMOS	vd0_out[5]					98
Y19	VDO_OUT_14	VOOUT	CMOS	vd0_out[14]					107
Y20	VDO_OUT_6	VOOUT	CMOS	vd0_out[6]					99
Y21	ENET_TXEN	ENET	CMOS	enet_txen	sc_a0	enet_txen	ssi1_sclk	norspi_clk	46
Y22	ENET_REF_CLK	ENET	CMOS	enet_ref_clk	sc_b3	enet_rx_clk		norspi_dq[3]	53
AA1	SSIOEN1	GPIO	CMOS	ssio_en1	norspi_en[1]				38
AA2	IDC2CLK	I2C/IDC	CMOS	idc1_clk		norspi_dq[2]	norspi_en[2]		29
AA3	USB_VDDA18_AA3	Power	Analog Supply						
AA4	USB0_REXT	USB	Analog						
AA5	USB0_DM	USB	Analog						
AA6	USB1_DM	USB	Analog						

Loc.	Pin Name	Group	Type	Multiplexed Functions					
				First	Second	Third	Fourth	Fifth	GPIO
AA7	SPCLK_LVDS_N_2	Sensor	Sub-LVDS/ SLVS/ LVCMOS/ MIPI						
AA8	SD_LVDS_N_8	Sensor	Sub-LVDS/ SLVS/ LVCMOS/ MIPI						
AA9	SD_LVDS_N_9	Sensor	Sub-LVDS/ SLVS/ LVCMOS/ MIPI						
AA10	SD_LVDS_N_3	Sensor	Sub-LVDS/ SLVS/ LVCMOS/ MIPI						
AA11	SD_LVDS_N_2	Sensor	Sub-LVDS/ SLVS/ LVCMOS/ MIPI						
AA12	SD_LVDS_N_1	Sensor	Sub-LVDS/ SLVS/ LVCMOS/ MIPI						
AA13	SD_LVDS_N_0	Sensor	Sub-LVDS/ SLVS/ LVCMOS/ MIPI						
AA14	SPCLK_LVDS_N_0	Sensor	Sub-LVDS/ SLVS/ LVCMOS/ MIPI						
AA15	SD_LVDS_N_7	Sensor	Sub-LVDS/ SLVS/ LVCMOS/ MIPI						
AA16	SD_LVDS_N_6	Sensor	Sub-LVDS/ SLVS/ LVCMOS/ MIPI						
AA17	SD_LVDS_N_5	Sensor	Sub-LVDS/ SLVS/ LVCMOS/ MIPI						



Loc.	Pin Name	Group	Type	Multiplexed Functions					
				First	Second	Third	Fourth	Fifth	GPIO
AA18	SD_LVDS_N_4	Sensor	Sub-LVDS/ SLVS/ LVCMOS/ MIPI						
AA19	SPCLK_LVDS_N_1	Sensor	Sub-LVDS/ SLVS/ LVCMOS/ MIPI						
AA20	ENET_CRS_DV	ENET	CMOS	enet_crs_dv	sc_b2	enet_crs_dv	ssi1_en3	norspi_dq[2]	52
AA21	ENET_TXD_1	ENET	CMOS	enet_txd_1	sc_a2	enet_txd_1	ssi1_rxd	norspi_dq[1]	48
AA22	ENET_RXD_1	ENET	CMOS	enet_rxd_1	sc_b0	enet_rxd_1	ssi1_en1	norspi_en[1]	50
AB1	SSIOENO	GPIO	CMOS	ssi0_en0	norspi_en[0]	uart_ahb_rts_n	ssis_en		37
AB2	IDC2DATA	I2C/IDC	CMOS	idc1data		norspi_dq[3]	norspi_en[3]		30
AB3	USB_VDDA18_AB3	Power	Analog Supply						
AB4	USB_DVDD	Power	Digital Supply						
AB5	USB0_DP	USB	Analog						
AB6	USB1_DP	USB	Analog						
AB7	SPCLK_LVDS_P_2	Sensor	Sub-LVDS/ SLVS/ LVCMOS/ MIPI						
AB8	SD_LVDS_P_8	Sensor	Sub-LVDS/ SLVS/ LVCMOS/ MIPI						
AB9	SD_LVDS_P_9	Sensor	Sub-LVDS/ SLVS/ LVCMOS/ MIPI						
AB10	SD_LVDS_P_3	Sensor	Sub-LVDS/ SLVS/ LVCMOS/ MIPI						
AB11	SD_LVDS_P_2	Sensor	Sub-LVDS/ SLVS/ LVCMOS/ MIPI						
AB12	SD_LVDS_P_1	Sensor	Sub-LVDS/ SLVS/ LVCMOS/ MIPI						

Loc.	Pin Name	Group	Type	Multiplexed Functions					
				First	Second	Third	Fourth	Fifth	GPIO
AB13	SD_LVDS_P_0	Sensor	Sub-LVDS/ SLVS/ LVCMOS/ MIPI						
AB14	SPCLK_LVDS_P_0	Sensor	Sub-LVDS/ SLVS/ LVCMOS/ MIPI						
AB15	SD_LVDS_P_7	Sensor	Sub-LVDS/ SLVS/ LVCMOS/ MIPI						
AB16	SD_LVDS_P_6	Sensor	Sub-LVDS/ SLVS/ LVCMOS/ MIPI						
AB17	SD_LVDS_P_5	Sensor	Sub-LVDS/ SLVS/ LVCMOS/ MIPI						
AB18	SD_LVDS_P_4	Sensor	Sub-LVDS/ SLVS/ LVCMOS/ MIPI						
AB19	SPCLK_LVDS_P_1	Sensor	Sub-LVDS/ SLVS/ LVCMOS/ MIPI						
AB20	ENET_RX_ER	ENET	CMOS	enet_rxer	sc_b1	enet_rxer	ssi1_en2	norspi_en[2]	51
AB21	ENET_TXD_0	ENET	CMOS	enet_txd_0	sc_a1	enet_txd_0	ssi1_txd	norspi_dq[0]	47
AB22	ENET_RXD_0	ENET	CMOS	enet_rxd_0	sc_a3	enet_rxd_0	ssi1_en0	norspi_en[0]	49

Table 7-1. Pin List and Mapping Table for the A12A35 Chip.

8. ADDITIONAL RESOURCES

Other Ambarella documents of potential interest include:

- *A12 Hardware Programming Reference Manual*
- *A12 AN: System Hardware*
- *Ambarella A-Series BOSS Connected Camera SDK: Build and Customize*
- *Ambarella ulTRON AN: Camera*
- *Ambarella ulTRON AN: Middleware*
- *Ambarella ulTRON AN: System*
- *A-Series Wireless Connectivity API: Remote Control*
- *B5 Chip Datasheets*

Confidential
For FORWARD Only

9. IMPORTANT NOTICE

All Ambarella design specifications, datasheets, drawings, files, and other documents (together and separately, “materials”) are provided on an “as is” basis, and Ambarella makes no warranties, expressed, implied, statutory, or otherwise with respect to the materials, and expressly disclaims all implied warranties of noninfringement, merchantability, and fitness for a particular purpose. The information contained herein is believed to be accurate and reliable. However, Ambarella assumes no responsibility for the consequences of use of such information.

Ambarella Incorporated reserves the right to correct, modify, enhance, improve, and otherwise change its products and services at any time and to discontinue any product or service without notice. Customers should obtain the latest relevant information before placing orders and should verify that such information is current and complete.

All products are sold subject to Ambarella’s terms and conditions of sale supplied at the time of order acknowledgment. Ambarella warrants performance of its hardware products to the specifications applicable at the time of sale in accordance with its standard warranty. Testing and other quality control techniques are used to the extent Ambarella deems necessary to support this warranty.

Ambarella assumes no liability for applications assistance or customer product design. Customers are responsible for their products and applications using Ambarella components. To minimize the risks associated with customer products and applications, customers should provide adequate design and operating safeguards.

Ambarella does not warrant or represent that any license, either expressed or implied, is granted under any Ambarella patent right, copyright, mask work right, or other intellectual property right relating to any combination, machine, or process in which Ambarella products or services are used. Information published by Ambarella regarding third-party products or services does not constitute a license from Ambarella to use such products or services or a warranty or endorsement thereof. Use of such information may require a license from a third party under the patents or other intellectual property of the third party, or a license from Ambarella under the patents or other intellectual property of Ambarella.

Reproduction of information from Ambarella documents is not permissible without prior approval from Ambarella.

Ambarella products are not authorized for use in safety-critical applications (such as life support) where a failure of the product would reasonably be expected to cause severe personal injury or death, unless officers of the parties have executed an agreement specifically governing such use. Customers acknowledge and agree that they are solely responsible for all legal, regulatory and safety-related requirements concerning their products and any use of Ambarella products in such safety-critical applications, notwithstanding any applications-related information or support that may be provided by Ambarella. Further, Customers must fully indemnify Ambarella and its representatives against any damages arising out of the use of Ambarella products in such safety-critical applications.

Ambarella products are neither designed nor intended for use in military/aerospace applications or environments. Customers acknowledge and agree that any such use of Ambarella products is solely at the Customer’s risk, and they are solely responsible for compliance with all legal and regulatory requirements in connection with such use.

10. TYPOGRAPHICAL CONVENTIONS

This document provides technical detail using a set of consistent typographical conventions to help the user differentiate key concepts at a glance. Conventions include:

Example	Description
AmbaGuiGen, DirectUSB Save, File > Save Power, Reset, Home	Software names GUI commands and command sequences Computer / Hardware buttons
Flash_IO_control da, status, enable	Register names and register fields. For example, Flash_IO_control is the register for global control of Flash I/O, and bit 17 (da) is used for DMA acknowledgement.
GPIO81, CLK_AU	Hardware external pins
VIL, VIH, VOL, VOH	Hardware pin parameters
INT_O, RXDATA_I	Hardware pin signals
amb_performance_t amb_operating_mode_t amb_set_operating_mode()	API details (e.g., functions, structures, and type definitions)
<pre> /usr/local/bin success = amb_set_operating_ mode (amb_hal_base_address, & operating_mode) </pre>	User entries into software dialogues and GUI windows File names and paths Command line scripting and Code

Table 10-1. *Typographical Conventions for Technical Documents.*

Additional Ambarella typographical conventions include:

- Acronyms are given in UPPER CASE using the default font (e.g., AHB, ARM11 and DDRIO).
- Names of Ambarella documents and publicly available standards, specifications, and databooks appear in *italic* type.

11. REVISION HISTORY

NOTE: Page/chapter numbers for previous drafts may differ from those in the current version.

Version	Date	Comments
0.1	26 November 2014	New A12A Part
0.2	17 December 2014	Update to version A1
0.3	24 February 2015	Update operating temperature range
0.4	19 March 2015	Update SD-related timing diagrams and specs; Change package dimensions

Table 11-1. Revision History.