



88E1111 Product Brief

Integrated 10/100/1000 Ultra
Gigabit Ethernet Transceiver





Doc. No. MV-S105540-00, Rev. --

March 4, 2009

Document Classification: Proprietary Information

Document Conventions

	Note: Provides related information or information of special importance.
	Caution: Indicates potential damage to hardware or software, or loss of data.
	Warning: Indicates a risk of personal injury.

Document Status

Advance Information	This document contains design specifications for initial product development. Specifications may change without notice. Contact Marvell Field Application Engineers for more information.
Preliminary Information	This document contains preliminary data, and a revision of this document will be published at a later date. Specifications may change without notice. Contact Marvell Field Application Engineers for more information.
Final Information	This document contains specifications on a product that is in final release. Specifications may change without notice. Contact Marvell Field Application Engineers for more information.
Doc Status: Advance	
Technical Publications: 1.00	

For more information, visit our website at: www.marvell.com

Disclaimer

No part of this document may be reproduced or transmitted in any form or by any means, electronic or mechanical, including photocopying and recording, for any purpose, without the express written permission of Marvell. Marvell retains the right to make changes to this document at any time, without notice. Marvell makes no warranty of any kind, expressed or implied, with regard to any information contained in this document, including, but not limited to, the implied warranties of merchantability or fitness for any particular purpose. Further, Marvell does not warrant the accuracy or completeness of the information, text, graphics, or other items contained within this document. Marvell products are not designed for use in life-support equipment or applications that would cause a life-threatening situation if any such products failed. Do not use Marvell products in these types of equipment or applications.

With respect to the products described herein, the user or recipient, in the absence of appropriate U.S. government authorization, agrees:

- 1) Not to re-export or release any such information consisting of technology, software or source code controlled for national security reasons by the U.S. Export Control Regulations ("EAR"), to a national of EAR Country Groups D:1 or E:2;
- 2) Not to export the direct product of such technology or such software, to EAR Country Groups D:1 or E:2, if such technology or software and direct products thereof are controlled for national security reasons by the EAR; and,
- 3) In the case of technology controlled for national security reasons under the EAR where the direct product of the technology is a complete plant or component of a plant, not to export to EAR Country Groups D:1 or E:2 the direct product of the plant or major component thereof, if such direct product is controlled for national security reasons by the EAR, or is subject to controls under the U.S. Munitions List ("USML").

At all times hereunder, the recipient of any such information agrees that they shall be deemed to have manually signed this document in connection with their receipt of any such information.

Copyright © 2009, Marvell International Ltd. All rights reserved. Marvell, the Marvell logo, Moving Forward Faster, Alaska, Fastwriter, Datacom Systems on Silicon, Libertas, Link Street, NetGX, PHYAdvantage, Prestera, Raising The Technology Bar, The Technology Within, Virtual Cable Tester, and Yukon are registered trademarks of Marvell. Ants, AnyVoltage, Discovery, DSP Switcher, Feroceon, GalNet, GalTis, Horizon, Marvell Makes It All Possible, RADLAN, UniMAC, and VCT are trademarks of Marvell. All other trademarks are the property of their respective owners.



OVERVIEW

The Alaska[®] Ultra 88E1111 Gigabit Ethernet Transceiver is a physical layer device for Ethernet 1000BASE-T, 100BASE-TX, and 10BASE-T applications. It is manufactured using standard digital CMOS process and contains all the active circuitry required to implement the physical layer functions to transmit and receive data on standard CAT 5 unshielded twisted pair.

The 88E1111 device incorporates the Marvell Virtual Cable Tester[®] (VCT[™]) feature, which uses Time Domain Reflectometry (TDR) technology for the remote identification of potential cable malfunctions, thus reducing equipment returns and service calls. Using VCT, the Alaska 88E1111 device detects and reports potential cabling issues such as pair swaps, pair polarity and excessive pair skew. The device will also detect cable opens, shorts or any impedance mismatch in the cable and report accurately within one meter the distance to the fault.

The 88E1111 device supports the Gigabit Media Independent Interface (GMII), Reduced GMII (RGMII), Serial Gigabit Media Independent Interface (SGMII), the Ten-Bit Interface (TBI), and Reduced TBI (RTBI) for direct connection to a MAC/Switch port.

The 88E1111 device incorporates an optional 1.25 GHz SERDES (Serializer/Deserializer). The serial interface may be connected directly to a fiber-optic transceiver for 1000BASE-T/1000BASE-X media conversion applications. Additionally, the 88E1111 device may be used to implement 1000BASE-T Gigabit Interface Converter (GBIC) or Small Form Factor Pluggable (SFP) modules.

The 88E1111 device uses advanced mixed-signal processing to perform equalization, echo and crosstalk cancellation, data recovery, and error correction at a gigabit per second data rate. The device achieves robust performance in noisy environments with very low power dissipation.

The 88E1111 device is offered in three different package options including a 117-Pin TFBGA, a 96-pin BCC featuring a body size of only 9 x 9 mm, and a 128 PQFP package.

FEATURES

- 10/100/1000BASE-T IEEE 802.3 compliant
- Supports GMII, TBI, reduced pin count GMII (RGMII), reduced pin count TBI (RTBI), and serial GMII (SGMII) interfaces
- Integrated 1.25 GHz SERDES for 1000BASE-X fiber applications
- Four RGMII timing modes
- Energy Detect and Energy Detect+ low power modes
- Three loopback modes for diagnostics
- “Downshift” mode for two-pair cable installations
- Fully integrated digital adaptive equalizers, echo cancellers, and crosstalk cancellers
- Advanced digital baseline wander correction
- Automatic MDI/MDIX crossover at all speeds of operation
- Automatic polarity correction
- IEEE 802.3u compliant Auto-Negotiation
- Software programmable LED modes including LED testing
- Automatic detection of fiber or copper operation
- Supports IEEE 1149.1 JTAG
- Two-Wire Serial Interface (TWSI) and MDC/MDIO
- CRC checker, packet counter
- Packet generation
- Virtual Cable Tester (VCT)
- Auto-Calibration for MAC Interface outputs
- Requires only two supplies: 2.5V and 1.0V (with 1.2V option for the 1.0V supply)
- I/Os are 3.3V tolerant
- Low power dissipation $P_{ave} = 0.75W$
- 117-Pin TFBGA, 96-Pin BCC, and 128 PQFP package options
- 117-Pin TFBGA and 96-Pin BCC packages available in Commercial or Industrial grade
- RoHS 6/6 compliant packages available

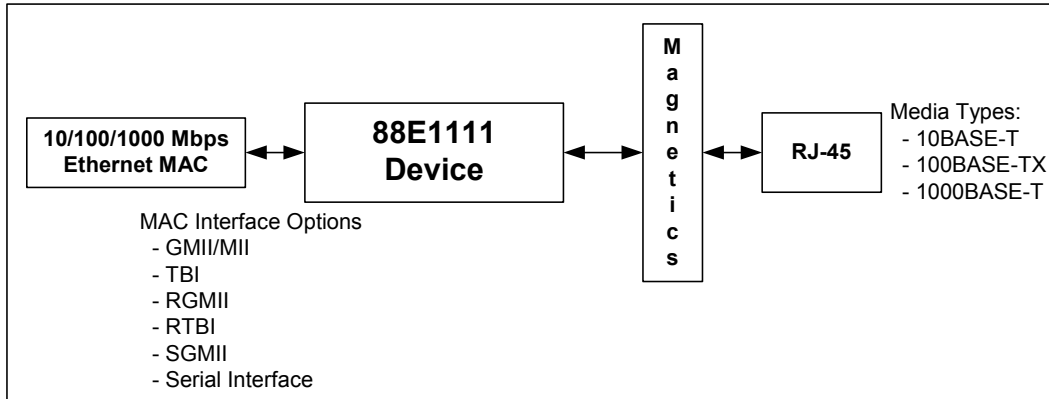

88E1111 Device used in Copper Application

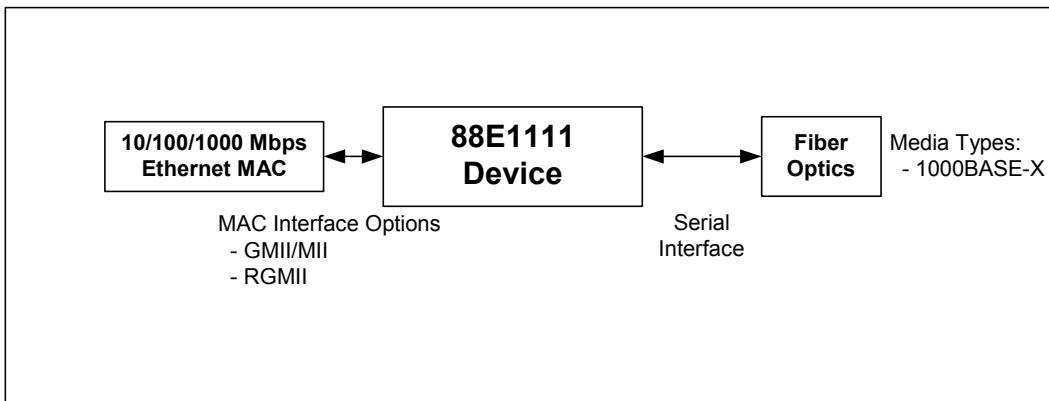

88E1111 Device used in Fiber Application

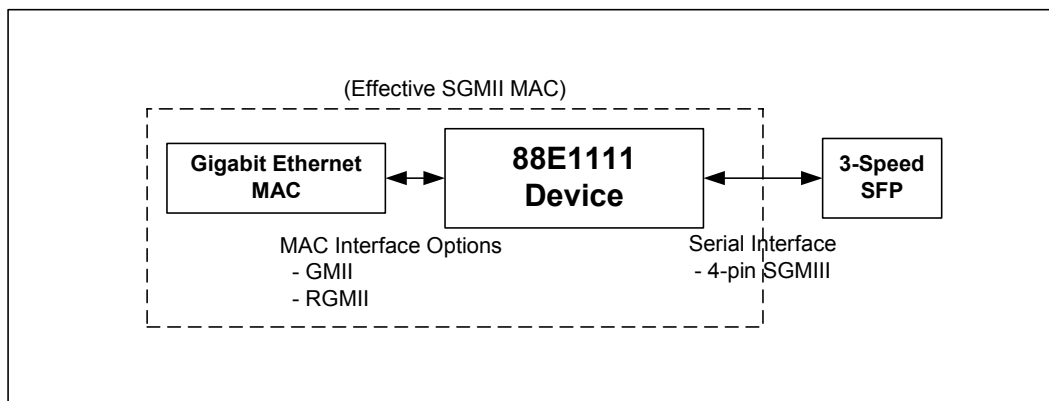

88E1111 RGMII/GMII MAC to SGMII MAC Conversion

Table of Contents

1.1	117-Pin TFBGA Package	6
1.2	96-Pin BCC Package	7
1.3	128-Pin PQFP Package	8
1.4	Pin Description	9
1.4.1	Pin Type Definitions.....	9
1.5	I/O State at Various Test or Reset Modes	33
1.6	117-Pin TFBGA Pin Assignment List - Alphabetical by Signal Name	34
1.7	96-Pin BCC Pin Assignment List - Alphabetical by Signal Name	36
1.8	128-Pin PQFP Pin Assignment List - Alphabetical by Signal Name	38
2.1	117-pin TFBGA Package	40
2.2	96-pin BCC Package - Top View	42
2.3	96-Pin BCC Package - Bottom View	43
2.4	128-Pin PQFP Package	44
3.1	Ordering Part Numbers and Package Markings	45
3.1.1	RoHS 5/6 Compliant Marking Examples	46
3.1.2	RoHS 6/6 Compliant Marking Examples	49

Section 1. Signal Description

The 88E1111 device is a 10/100/1000BASE-T/1000BASE-X Gigabit Ethernet transceiver.

1.1 117-Pin TFBGA Package

Figure 1: 88E1111 Device 117-Pin TFBGA Package (Top View)

	1	2	3	4	5	6	7	8	9	
A	RXD5	RXD6	S_IN+	S_IN-	S_CLK+	S_CLK-	S_OUT+	S_OUT-	LED_LINK1000	A
B	RX_DV	RXD0	RXD3	VDDO	CRS	COL	AVDD	LED_LINK100	VDDOH	B
C	RX_CLK	VDDO	RXD2	RXD4	RXD7	DVDD	DVDD	LED_LINK10	LED_RX	C
D	TX_CLK	RX_ER	RXD1	VSS	VSS	VSS	DVDD	CONFIG[0]	LED_TX	D
E	TX_EN	GTX_CLK	DVDD	VSS	VSS	VSS	DVDD	LED_DUPLEX	CONFIG[1]	E
F	TXD0	TX_ER	DVDD	VSS	VSS	VSS	VDDOH	CONFIG[2]	CONFIG[4]	F
G	NC	TXD1	TXD2	VSS	VSS	VSS	CONFIG[3]	CONFIG[6]	CONFIG[5]	G
H	TXD4	TXD3	TXD5	VSS	VSS	VSS	VSSC	SEL_FREQ	XTAL1	H
J	TXD6	TXD7	DVDD	VSS	VSS	VSS	DVDD	VDDOH	XTAL2	J
K	VDDO	125CLK	RESETn	VSS	VSS	VSS	NC	TDO	VDDOX	K
L	INTn	VDDOX	MDC	COMA	VSS	VSS	TDI	TMS	TCK	L
M	MDIO	RSET	AVDD	AVDD	HSDAC+	HSDAC-	AVDD	AVDD	TRSTn	M
N	MDI[0]+	MDI[0]-	MDI[1]+	MDI[1]-	AVDD	MDI[2]+	MDI[2]-	MDI[3]+	MDI[3]-	N
	1	2	3	4	5	6	7	8	9	

Figure 2: Pin A1 Location

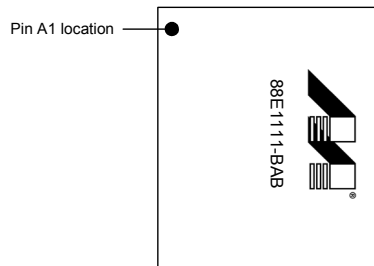

1.2 96-Pin BCC Package

Figure 3: 88E1111 Device 96-Pin BCC Package (Top View)

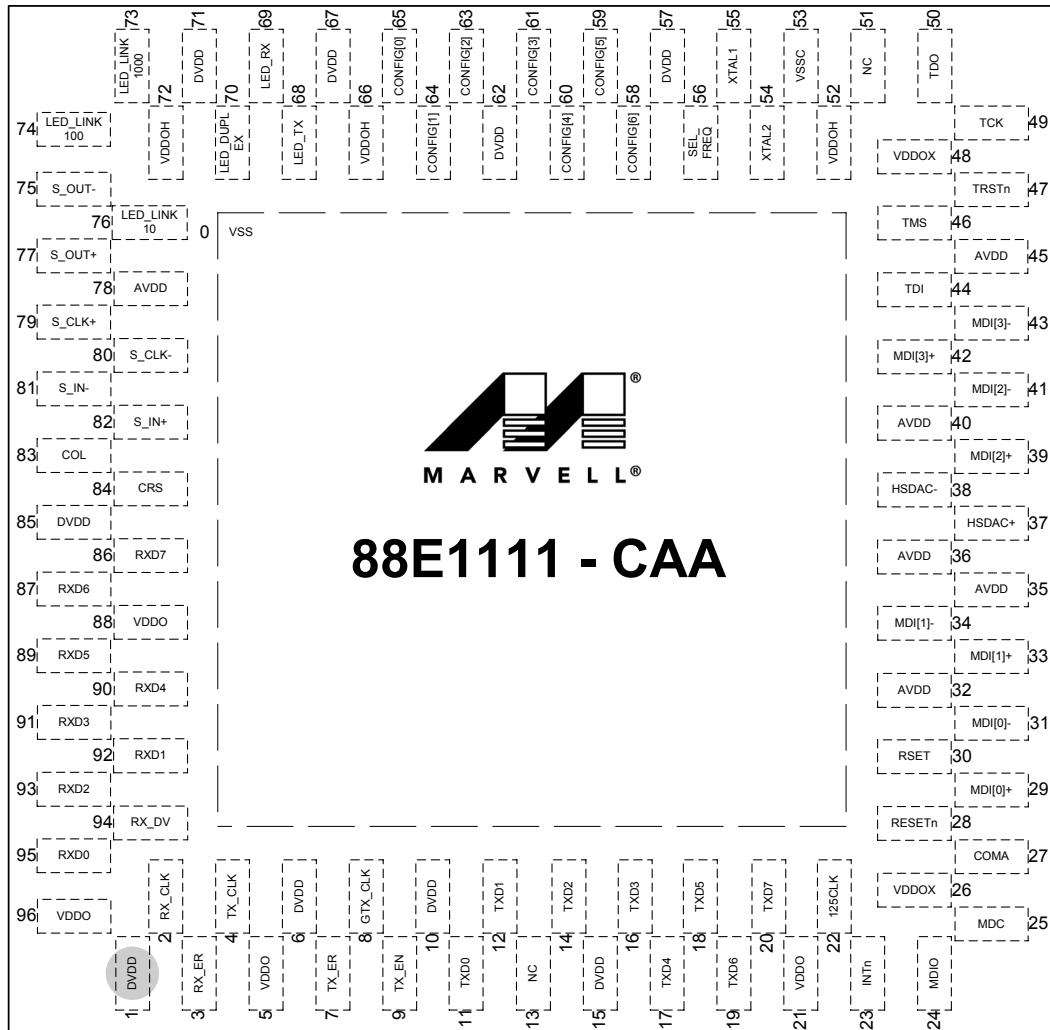



1.3 128-Pin PQFP Package

Figure 4: 88E1111 Device 128-Pin PQFP Package (Top View)

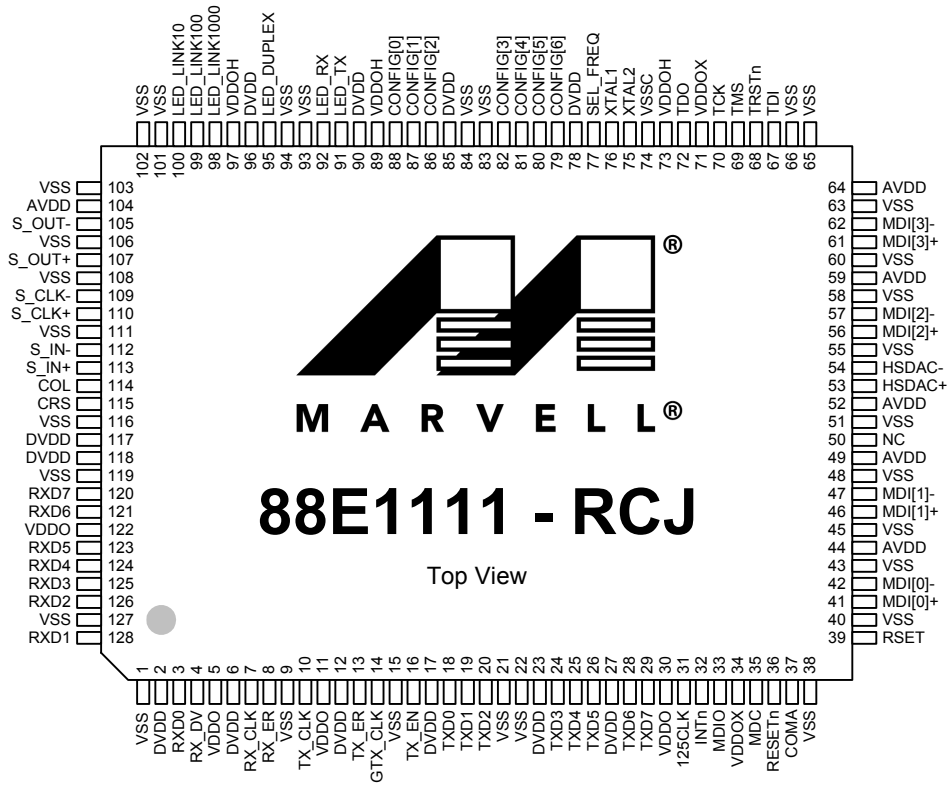

1.4 Pin Description

1.4.1 Pin Type Definitions

Pin Type	Definition
H	Input with hysteresis
I/O	Input and output
I	Input only
O	Output only
PU	Internal pull up
PD	Internal pull down
D	Open drain output
Z	Tri-state output
mA	DC sink capability



Table 1: Media Dependent Interface

117-TFBGA Pin #	96-BCC Pin #	128-PQFP Pin #	Pin Name	Pin Type	Description
N1 N2	29 31	41 42	MDI[0]+ MDI[0]-	I/O, D	<p>Media Dependent Interface[0].</p> <p>In 1000BASE-T mode in MDI configuration, MDI[0]± correspond to BI_DA±. In MDIX configuration, MDI[0]± correspond to BI_DB±.</p> <p>In 100BASE-TX and 10BASE-T modes in MDI configuration, MDI[0]± are used for the transmit pair. In MDIX configuration, MDI[0]± are used for the receive pair.</p> <p>MDI[0]± should be tied to ground if not used.</p>
N3 N4	33 34	46 47	MDI[1]+ MDI[1]-	I/O, D	<p>Media Dependent Interface[1].</p> <p>In 1000BASE-T mode in MDI configuration, MDI[1]± correspond to BI_DB±. In MDIX configuration, MDI[1]± correspond to BI_DA±.</p> <p>In 100BASE-TX and 10BASE-T modes in MDI configuration, MDI[1]± are used for the receive pair. In MDIX configuration, MDI[1]± are used for the transmit pair.</p> <p>MDI[1]± should be tied to ground if not used.</p>

Table 1: Media Dependent Interface (Continued)

117-TFBGA Pin #	96-BCC Pin #	128-PQFP Pin #	Pin Name	Pin Type	Description
N6 N7	39 41	56 57	MDI[2]+ MDI[2]-	I/O, D	Media Dependent Interface[2]. In 1000BASE-T mode in MDI configuration, MDI[2] \pm correspond to BI_DC \pm . In MDIX configuration, MDI[2] \pm corresponds to BI_DD \pm . In 100BASE-TX and 10BASE-T modes, MDI[2] \pm are not used. MDI[2] \pm should be tied to ground if not used.
N8 N9	42 43	61 62	MDI[3]+ MDI[3]-	I/O, D	Media Dependent Interface[3]. In 1000BASE-T mode in MDI configuration, MDI[3] \pm correspond to BI_DD \pm . In MDIX configuration, MDI[3] \pm correspond to BI_DC \pm . In 100BASE-TX and 10BASE-T modes, MDI[3] \pm are not used. MDI[3] \pm should be tied to ground if not used.



The GMII interface supports both 1000BASE-T and 1000BASE-X modes of operation. The GMII interface pins are also used for the TBI interface. See [Table 3](#) for TBI pin definitions. The MAC interface pins are 3.3V tolerant.

Table 2: GMII/MII Interfaces

117-TFBGA Pin #	96-BCC Pin #	128-PQFP Pin #	Pin Name	Pin Type	Description
E2	8	14	GTX_CLK	I	GMII Transmit Clock. GTX_CLK provides a 125 MHz clock reference for TX_EN, TX_ER, and TXD[7:0]. This clock can be stopped when the device is in 10/100BASE-T modes, and also during Auto-Negotiation.
D1	4	10	TX_CLK	O, Z	MII Transmit Clock. TX_CLK provides a 25 MHz clock reference for TX_EN, TX_ER, and TXD[3:0] in 100BASE-TX mode, and a 2.5 MHz clock reference in 10BASE-T mode. TX_CLK provides a 25 MHz, 2.5 MHz, or 0 MHz clock during 1000 Mbps Good Link, Auto-Negotiation, and Link Lost states depending on the setting of register 20.6:4. The 2.5 MHz clock is the default rate, which may be programmed to another frequency by writing to register 20.6:4.
E1	9	16	TX_EN	I	GMII and MII Transmit Enable. In GMII/MII mode when TX_EN is asserted, data on TXD[7:0] along with TX_ER is encoded and transmitted onto the cable. TX_EN is synchronous to GTX_CLK, and synchronous to TX_CLK in 100BASE-TX and 10BASE-T modes.
F2	7	13	TX_ER	I	GMII and MII Transmit Error. In GMII/MII mode when TX_ER and TX_EN are both asserted, the transmit error symbol is transmitted onto the cable. When TX_ER is asserted with TX_EN de-asserted, carrier extension symbol is transmitted onto the cable. TX_ER is synchronous to GTX_CLK, and synchronous to TX_CLK in 100BASE-TX and 10BASE-T modes.

Table 2: GMII/MII Interfaces (Continued)

117-TFBGA Pin #	96-BCC Pin #	128-PQFP Pin #	Pin Name	Pin Type	Description
J2 J1 H3 H1 H2 G3 G2 F1	20 19 18 17 16 14 12 11	29 28 26 25 24 20 19 18	TXD[7] TXD[6] TXD[5] TXD[4] TXD[3]/TXD[3] TXD[2]/TXD[2] TXD[1]/TXD[1] TXD[0]/TXD[0]	I	<p>GMII and MII Transmit Data. In GMII mode, TXD[7:0] present the data byte to be transmitted onto the cable in 1000BASE-T mode.</p> <p>In MII mode, TXD[3:0] present the data nibble to be transmitted onto the cable in 100BASE-TX and 10BASE-T modes. TXD[7:4] are ignored in these modes, but should be driven either high or low. These pins must not float.</p> <p>TXD[7:0] are synchronous to GTX_CLK, and synchronous to TX_CLK in 100BASE-TX and 10BASE-T modes.</p> <p>Inputs TXD[7:4] should be tied low if not used (e.g., RGMII mode).</p>
C1	2	7	RX_CLK	O, Z	<p>GMII and MII Receive Clock. RX_CLK provides a 125 MHz clock reference for RX_DV, RX_ER, and RXD[7:0] in 1000BASE-T mode, a 25 MHz clock reference in 100BASE-TX mode, and a 2.5 MHz clock reference in 10BASE-T mode.</p> <p>TX_TCLK comes from the RX_CLK pins used in jitter testing. Refer to Register 9 for jitter test modes.</p>
B1	94	4	RX_DV	O, Z	<p>GMII and MII Receive Data Valid. When RX_DV is asserted, data received on the cable is decoded and presented on RXD[7:0] and RX_ER.</p> <p>RX_DV is synchronous to RX_CLK.</p>
D2	3	8	RX_ER	O, Z	<p>GMII and MII Receive Error. When RX_ER and RX_DV are both asserted, the signals indicate an error symbol is detected on the cable.</p> <p>When RX_ER is asserted with RX_DV deasserted, a false carrier or carrier extension symbol is detected on the cable.</p> <p>RX_ER is synchronous to RX_CLK.</p>



Table 2: GMII/MII Interfaces (Continued)

117-TFBGA Pin #	96-BCC Pin #	128-PQFP Pin #	Pin Name	Pin Type	Description
C5 A2 A1 C4 B3 C3 D3 B2	86 87 89 90 91 93 92 95	120 121 123 124 125 126 128 3	RXD[7] RXD[6] RXD[5] RXD[4] RXD[3]/RXD[3] RXD[2]/RXD[2] RXD[1]/RXD[1] RXD[0]/RXD[0]	O, Z	<p>GMII and MII Receive Data. Symbols received on the cable are decoded and presented on RXD[7:0] in 1000BASE-T mode.</p> <p>In MII mode, RXD[3:0] are used in 100BASE-TX and 10BASE-T modes. In MII mode, RXD[7:4] are driven low.</p> <p>RXD[7:0] is synchronous to RX_CLK.</p>
B5	84	115	CRS	O, Z	<p>GMII and MII Carrier Sense. CRS asserts when the receive medium is non-idle. In half-duplex mode, CRS is also asserted during transmission. CRS assertion during half-duplex transmit can be disabled by programming register 16.11 to 0.</p> <p>CRS is asynchronous to RX_CLK, GTX_CLK, and TX_CLK.</p>
B6	83	114	COL	O, Z	<p>GMII and MII Collision. In 10/100/1000BASE-T full-duplex modes, COL is always low. In 10/100/1000BASE-T half-duplex modes, COL asserts only when both the transmit and receive media are non-idle.</p> <p>In 10BASE-T half-duplex mode, COL is asserted to indicate signal quality error (SQE). SQE can be disabled by clearing register 16.2 to zero.</p> <p>COL is asynchronous to RX_CLK, GTX_CLK, and TX_CLK.</p>

The TBI interface supports 1000BASE-T mode of operation. The TBI interface uses the same pins as the GMII interface. The MAC interface pins are 3.3V tolerant.

Table 3: TBI Interface

117-TFBGA Pin #	96-BCC Pin #	128-PQFP Pin #	Pin Name	Pin Type	Description
E2	8	14	GTX_CLK/ TBI_TXCLK	I	TBI Transmit Clock. In TBI mode, GTX_CLK is used as TBI_TXCLK. TBI_TXCLK is a 125 MHz transmit clock. TBI_TXCLK provides a 125 MHz clock reference for TX_EN, TX_ER, and TXD[7:0].
D1	4	10	TX_CLK/RCLK1	O, Z	TBI 62.5 MHz Receive Clock- even code group. In TBI mode, TX_CLK is used as RCLK1.
J2 J1 H3 H1 H2 G3 G2 F1	20 19 18 17 16 14 12 11	29 28 26 25 24 20 19 18	TXD[7] TXD[6] TXD[5] TXD[4] TXD[3] TXD[2] TXD[1] TXD[0]	I	TBI Transmit Data. TXD[7:0] presents the data byte to be transmitted onto the cable. TXD[9:0] are synchronous to GTX_CLK. Inputs TXD[7:4] should be tied low if not used (e.g., RTBI mode).
E1	9	16	TX_EN/ TXD8	I	TBI Transmit Data. In TBI mode, TX_EN is used as TXD8. TXD[9:0] are synchronous to GTX_CLK.
F2	7	13	TX_ER/ TXD9	I	TBI Transmit Data. In TBI mode, TX_ER is used as TXD9. TXD[9:0] are synchronous to GTX_CLK. TX_ER should be tied low if not used (e.g., RTBI mode).
C1	2	7	RX_CLK/ RCLK0	O, Z	TBI 62.5 MHz Receive Clock- odd code group. In the TBI mode, RX_CLK is used as RCLK0.
C5 A2 A1 C4 B3 C3 D3 B2	86 87 89 90 91 93 92 95	120 121 123 124 125 126 128 3	RXD[7] RXD[6] RXD[5] RXD[4] RXD[3] RXD[2] RXD[1] RXD[0]	O, Z	TBI Receive Data code group [7:0]. In the TBI mode, RXD[7:0] present the data byte to be transmitted to the MAC. Symbols received on the cable are decoded and presented on RXD[7:0]. RXD[7:0] are synchronous to RCLK0 and RCLK1.
B1	94	4	RX_DV/ RXD8	O, Z	TBI Receive Data code group bit 8. In the TBI mode, RX_DV is used as RXD8. RXD[9:0] are synchronous to RCLK0 and RCLK1.



Table 3: TBI Interface (Continued)

117-TFBGA Pin #	96-BCC Pin #	128-PQFP Pin #	Pin Name	Pin Type	Description
D2	3	8	RX_ER/ RXD9	O, Z	TBI Receive Data code group bit 9. In the TBI mode, RX_ER is used as RXD9. RXD[9:0] are synchronous to RCLK0 and RCLK1.
B5	84	115	CRS/ COMMA	O, Z	TBI Valid Comma Detect. In the TBI mode, CRS is used as COMMA.
B6	83	114	COL/LPBK	I	TBI Mode Loopback. In the TBI mode, COL is used to indicate loopback on the TBI. When a "0 - 1" transition is sampled on this pin, bit 0.14 is set to 1. When a "1 - 0" is sampled on this pin, bit 0.14 is reset to 0. If this feature is not used, the COL pin should be driven low on the board. This pin should not be left floating in TBI mode.

The RGMII interface supports 10/100/1000BASE-T and 1000BASE-X modes of operation. The RGMII interface pins are also used for the RTBI interface. See [Table 5](#) for RTBI pin definitions. The MAC interface pins are 3.3V tolerant.

Table 4: RGMII Interface

117-TFBGA Pin #	96-BCC Pin #	128-PQFP Pin #	Pin Name	Pin Type	Description
E2	8	14	GTX_CLK/ TXC	I	RGMII Transmit Clock provides a 125 MHz, 25 MHz, or 2.5 MHz reference clock with \pm 50 ppm tolerance depending on speed. In RGMII mode, GTX_CLK is used as TXC.
H2 G3 G2 F1	16 14 12 11	24 20 19 18	TXD[3]/TD[3] TXD[2]/TD[2] TXD[1]/TD[1] TXD[0]/TD[0]	I	RGMII Transmit Data. In RGMII mode, TXD[3:0] are used as TD[3:0]. In RGMII mode, TXD[3:0] run at double data rate with bits [3:0] presented on the rising edge of GTX_CLK, and bits [7:4] presented on the falling edge of GTX_CLK. In this mode, TXD[7:4] are ignored. In RGMII 10/100BASE-T modes, the transmit data nibble is presented on TXD[3:0] on the rising edge of GTX_CLK.
E1	9	16	TX_EN/ TX_CTL	I	RGMII Transmit Control. In RGMII mode, TX_EN is used as TX_CTL. TX_EN is presented on the rising edge of GTX_CLK. A logical derivative of TX_EN and TX_ER is presented on the falling edge of GTX_CLK.
C1	2	7	RX_CLK/ RXC	O, Z	RGMII Receive Clock provides a 125 MHz, 25 MHz, or 2.5 MHz reference clock with \pm 50 ppm tolerance derived from the received data stream depending on speed. In RGMII mode, RX_CLK is used as RXC.
B1	94	4	RX_DV/ RX_CTL	O, Z	RGMII Receive Control. In RGMII mode, RX_DV is used as RX_CTL. RX_DV is presented on the rising edge of RX_CLK. A logical derivative of RX_DV and RX_ER is presented on the falling edge of RX_CLK.
B3 C3 D3 B2	91 93 92 95	125 126 128 3	RXD[3]/RD[3] RXD[2]/RD[2] RXD[1]/RD[1] RXD[0]/RD[0]	O, Z	RGMII Receive Data. In RGMII mode, RXD[3:0] are used as RD[3:0]. In RGMII mode, RXD[3:0] run at double data rate with bits [3:0] presented on the rising edge of RX_CLK, and bits [7:4] presented on the falling edge of RX_CLK. In this mode, RXD[7:4] are ignored. In RGMII 10/100BASE-T modes, the receive data nibble is presented on RXD[3:0] on the rising edge of RX_CLK. RXD[3:0] are synchronous to RX_CLK.



The RTBI interface supports 1000BASE-T mode of operation. The RTBI interface uses the same pins as the RGMII interface. The MAC interface pins are 3.3V tolerant.

Table 5: RTBI Interface

117-TFBGA Pin #	96-BCC Pin #	128-PQFP Pin #	Pin Name	Pin Type	Description
E2	8	14	GTX_CLK/ TXC	I	RGMII Transmit Clock provides a 125 MHz reference clock with ± 50 ppm tolerance. In RTBI mode, GTX_CLK is used as TXC.
H2 G3 G2 F1	16 14 12 11	24 20 19 18	TXD[3]/TD[3] TXD[2]/TD[2] TXD[1]/TD[1] TXD[0]/TD[0]	I	RTBI Transmit Data. In RTBI mode, TXD[3:0] are used as TD[3:0]. TD[3:0] run at double data rate with bits [3:0] presented on the rising edge of GTX_CLK, and bits [8:5] presented on the falling edge of GTX_CLK. In this mode, TXD[7:4] are ignored.
E1	9	16	TX_EN/ TD4_TD9	I	RTBI Transmit Data. In RTBI mode, TX_EN is used as TD4_TD9. TD4_TD9 runs at a double data rate with bit 4 presented on the rising edge of GTX_CLK, and bit 9 presented on the falling edge of GTX_CLK.
C1	2	7	RX_CLK/ RXC	O, Z	RTBI Receive Clock provides a 125 MHz reference clock with ± 50 ppm tolerance derived from the received data stream. In RTBI mode, RX_CLK is used as RXC.
B3 C3 D3 B2	91 93 92 95	125 126 128 3	RXD[3]/RD[3] RXD[2]/RD[2] RXD[1]/RD[1] RXD[0]/RD[0]	O, Z	RTBI Receive Data. In RTBI mode, RXD[3:0] are used as RD[3:0]. RD[3:0] runs at double data rate with bits [3:0] presented on the rising edge of RX_CLK, and bits [8:5] presented on the falling edge of RX_CLK. In this mode, RXD[7:4] are ignored.
B1	94	4	RX_DV/ RD4_RD9	O, Z	RTBI Receive Data. In RTBI mode, RX_DV is used as RD4_RD9. RD4_RD9 runs at a double data rate with bit 4 presented on the rising edge of RX_CLK, and bit 9 presented on the falling edge of RX_CLK.

Table 6: SGMII Interface

117-TFBGA Pin #	96-BCC Pin #	128-PQFP Pin #	Pin Name	Pin Type	Description
A3 A4	82 81	113 112	S_IN+ S_IN-	I	SGMII Transmit Data. 1.25 GBaud input - Positive and Negative. Input impedance on the S_IN± pins may be programmed for 50 ohm or 75 ohm impedance by setting register 26.6. The input impedance default setting is determined by the 75/50 OHM configuration pin.
A5 A6	79 80	110 109	S_CLK+ S_CLK-	I/O	SGMII 625 MHz Receive Clock. For Serial Interface modes (HWCFG_MODE[3:0] = 1x00) the S_CLK± pins become Signal Detect± (SD±) inputs.
A7 A8	77 75	107 105	S_OUT+ S_OUT-	O, Z	SGMII Receive Data. 1.25 GBaud output - Positive and Negative. Output impedance on the S_OUT± pins may be programmed for 50 ohm or 75 ohm impedance by setting register 26.5. Output amplitude can be adjusted via register 26.2:0. The output impedance default setting is determined by the 75/50 OHM configuration pin.

Table 7: 1.25 GHz Serial High Speed Interface

117-TFBGA Pin #	96-BCC Pin #	128-PQFP Pin #	Pin Name	Pin Type	Description
A3 A4	82 81	113 112	S_IN+ S_IN-	I	<p>1.25 GHz input - Positive and Negative. When this interface is used as a MAC interface, the MAC transmitter's positive output connects to the S_IN+. The MAC transmitter's negative output connects to the S_IN-.</p> <p>When this interface is used as a fiber interface, the fiber-optic transceiver's positive output connects to the S_IN+. The fiber-optic transceiver's negative output connects to the S_IN-.</p> <p>Input impedance on the S_IN± pins may be programmed for 50 ohm or 75 ohm impedance by setting register 26.6. The input impedance default setting is determined by the 75/50 OHM configuration pin.</p>
A5 A6	79 80	110 109	S_CLK+/SD+ S_CLK-/SD-	I	<p>Signal Detect input.</p> <p>For Serial Interface modes the S_CLK± pins become Signal Detect± (SD±) inputs.</p>
A7 A8	77 75	107 105	S_OUT+ S_OUT-	O, Z	<p>1.25 GHz output – Positive and Negative. When this interface is used as a MAC interface, S_OUT+ connects to the MAC receiver's positive input. S_OUT- connects to the MAC receiver's negative input.</p> <p>When this interface is used as a fiber interface, S_OUT+ connects to the fiber-optic transceiver's positive input. S_OUT- connects to the fiber-optic transceiver's negative input.</p> <p>Output impedance on the S_OUT± pins may be programmed for 50 ohm or 75 ohm impedance by setting register 26.5. Output amplitude can be adjusted via register 26.2:0. The output impedance default setting is determined by the 75/50 OHM configuration pin.</p>
B3	91	125	RXD[3]	O, Z	<p>Serial MAC interface Copper Link Status[1] connection.</p> <p>1 = Copper link up 0 = Copper link down</p>

Table 7: 1.25 GHz Serial High Speed Interface (Continued)

117-TFBGA Pin #	96-BCC Pin #	128-PQFP Pin #	Pin Name	Pin Type	Description
C3	93	126	RXD[2]	O, Z	Serial MAC interface Copper Link Status[0] connection. 1 = Copper link down 0 = Copper link up
D3	92	128	RXD[1]	O, Z	Serial MAC interface PHY_SIGDET[1] connection. 1 = S_OUT± valid code groups according to clause 36. 0 = S_OUT± invalid
B2	95	3	RXD[0]	O, Z	Serial MAC interface PHY_SIGDET[0] connection. 1 = S_OUT± invalid 0 = S_OUT± valid code groups according to clause 36



Table 8: Management Interface and Interrupt

117-TFBGA Pin #	96-BCC Pin #	128-PQFP Pin #	Pin Name	Pin Type	Description
L3	25	35	MDC	I 3.3V Tolerant	MDC is the management data clock reference for the serial management interface. A continuous clock stream is not expected. The maximum frequency supported is 8.3 MHz.
M1	24	33	MDIO	I/O 3.3V Tolerant	MDIO is the management data. MDIO transfers management data in and out of the device synchronously to MDC. This pin requires a pull-up resistor in a range from 1.5 kohm to 10 kohm.
L1	23	32	INTn	D	The polarity of the INTn pin may be programmed at hardware reset by setting the INT_POL bit. Polarity: 0 = Active High 1 = Active Low

Table 9: Two-Wire Serial Interface

117-TFBGA Pin #	96-BCC Pin #	128-PQFP Pin #	Pin Name	Pin Type	Description
L3	25	35	MDC/SCL	I	Two-Wire Serial Interface (TWSI) serial clock line. When the 88E1111 device is connected to the bus, MDC connects to the serial clock line (SCL). Data is input on the rising edge of SCL, and output on the falling edge.
M1	24	33	MDIO/SDA	I/O	TWSI serial data line. When the 88E1111 device is connected to the bus, MDIO connects to the serial data line (SDA). This pin is open-drain and may be wire-ORed with any number of open-drain devices.

Table 10: LED Interface

117-TFBGA Pin #	96-BCC Pin #	128-PQFP Pin #	Pin Name	Pin Type	Description
C8	76	100	LED_LINK10	O, mA	<p>Parallel LED output for 10BASE-T link or speed. This active low LED pin may be programmed in direct drive or combined LED modes by programming register LED_LINK Control register 24.4:3.</p> <p>In direct drive LED mode, this pin indicates 10 Mbps link up or down.</p> <p>In combined LED mode, the output from LED_LINK10, LED_LINK100, and LED_LINK1000 must be read together to determine link and speed status.</p> <p>LED_LINK10 is a multi-function pin used to configure the 88E1111 device at the de-assertion of hardware reset.</p>
B8	74	99	LED_LINK100	O, mA	<p>Parallel LED output for 100BASE-TX link or speed. This active low LED pin may be programmed in direct drive or combined LED modes by programming register LED_LINK Control register 24.4:3.</p> <p>In direct drive LED mode, this pin indicates 100 Mbps link up or down.</p> <p>In combined LED mode, the output from LED_LINK10, LED_LINK100, and LED_LINK1000 must be read together to determine link and speed status.</p> <p>LED_LINK100 is a multi-function pin used to configure the 88E1111 device at the de-assertion of hardware reset.</p>
A9	73	98	LED_LINK1000	O, mA	<p>Parallel LED output for 1000BASE-T link/speed or link indicator. This active low LED pin may be programmed in direct drive or combined LED modes by programming register LED_LINK Control register 24.4:3.</p> <p>In direct drive LED mode, this pin indicates 1000 Mbps link up or down.</p> <p>In combined LED mode, the output from LED_LINK1000 indicates link status.</p> <p>LED_LINK1000 is a multi-function pin used to configure the 88E1111 device at the de-assertion of hardware reset.</p>



Table 10: LED Interface (Continued)

117-TFBGA Pin #	96-BCC Pin #	128-PQFP Pin #	Pin Name	Pin Type	Description
E8	70	95	LED_DUPLEX	O, mA	<p>Parallel LED duplex or duplex/collision modes. The LED_DUPLEX pin may be programmed to Mode 1 or Mode 2 by setting register bit 24.2.</p> <p>Mode 1 Low = Full-duplex High = Half-duplex Blink = Collision</p> <p>Mode 2 Low = Full-duplex High = Half-duplex</p> <p>Mode 3 Low = Fiber Link up High = Fiber Link down</p> <p>LED_DUPLEX is a multi-function pin used to configure the 88E1111 device at the de-assertion of hardware reset.</p>

Table 10: LED Interface (Continued)

117-TFBGA Pin #	96-BCC Pin #	128-PQFP Pin #	Pin Name	Pin Type	Description
C9	69	92	LED_RX	O, mA	<p>Parallel LED Receive Activity or Receive Activity/Link modes. LED_RX may be programmed to Mode 1 or Mode 2 by setting register bit 24.1.</p> <p>Mode 1 Low = Receiving High = Not receiving</p> <p>Mode 2 Low = Link up High = Link down Blink = Receiving</p> <p>LED_RX is a multi-function pin used to configure the 88E1111 device at the de-assertion of hardware reset.</p>
D9	68	91	LED_TX	O, mA	<p>Parallel LED Transmit Activity or RX/TX Activity/Link modes. LED_TX may be programmed to Mode 1 or Mode 2 by setting register bit 24.0.</p> <p>Mode 1 Low = Transmitting High = Not transmitting</p> <p>Mode 2 Low = Link up High = Link down Blink = Transmitting or receiving</p> <p>LED_TX is a multi-function pin used to configure the 88E1111 device at the de-assertion of hardware reset.</p>



Table 11: JTAG Interface

117-TFBGA Pin #	96-BCC Pin #	128-PQFP Pin #	Pin Type	Pin Name	Description
L7	44	67	TDI	I, PU	Boundary scan test data input. TDI contains an internal 150 kohm pull-up resistor.
L8	46	69	TMS	I, PU	Boundary scan test mode select input. TMS contains an internal 150 kohm pull-up resistor.
L9	49	70	TCK	I, PU	Boundary scan test clock input. TCK contains an internal 150 kohm pull-up resistor.
M9	47	68	TRSTn	I, PU	Boundary scan test reset input. Active low. TRSTn contains an internal 150 kohm pull-up resistor as per the 1149.1 specification. After power up, the JTAG state machine should be reset by applying a low signal on this pin, or by keeping TMS high and applying 5 TCK pulses, or by pulling this pin low by a 4.7 kohm resistor.
K8	50	72	TDO	O, Z	Boundary scan test data output.

Table 12: Clock/Configuration/Reset/I/O

117-TFBGA Pin #	96-BCC Pin #	128-PQFP Pin #	Pin Name	Pin Type	Description
K2	22	31	125CLK	O	Clock 125. A generic 125 MHz clock reference generated for use on the MAC device. This output can be disabled via DIS_125 through the CONFIG[3] pin.
D8	65	88	CONFIG[0]	I	<p>CONFIG[0] pin configures PHY_ADR[2:0] bits of the physical address.</p> <p>Each LED pin is hardwired to a constant value. The values associated to the CONFIG[0] pin are latched at the de-assertion of hardware reset.</p> <p>CONFIG[0] pin must be tied to one of the pins based on the configuration options selected. They should not be left floating.</p> <p>For the Two-Wire Serial Interface (TWSI) device address, the lower 5 bits, which are PHYADR[4:0], are latched during hardware reset, and the device address bits [6:5] are fixed at '10'.</p>
E9	64	87	CONFIG[1]	I	<p>CONFIG[1] pin configures PHY_ADR[4:3] and ENA_PAUSE options.</p> <p>Each LED pin is hardwired to a constant value. The values associated to the CONFIG[1] pin are latched at the de-assertion of hardware reset.</p> <p>CONFIG[1] pin must be tied to one of the pins based on the configuration options selected. They should not be left floating.</p> <p>For the TWSI device address, the lower 5 bits, which are PHYADR[4:0], are latched during hardware reset, and the device address bits [6:5] are fixed at '10'.</p>
F8	63	86	CONFIG[2]	I	<p>CONFIG[2] pin configures ANEG[3:1] bits.</p> <p>Each LED pin is hardwired to a constant value. The values associated to the CONFIG[2] pin are latched at the de-assertion of hardware reset.</p> <p>CONFIG[2] pin must be tied to one of the pins based on the configuration options selected. They should not be left floating.</p>



Table 12: Clock/Configuration/Reset/I/O (Continued)

117-TFBGA Pin #	96-BCC Pin #	128-PQFP Pin #	Pin Name	Pin Type	Description
G7	61	82	CONFIG[3]	I	<p>CONFIG[3] pin configures ANEG[0], ENA_XC, and DIS_125 options.</p> <p>Each LED pin is hardwired to a constant value. The values associated to the CONFIG[3] pin are latched at the de-assertion of hardware reset.</p> <p>CONFIG[3] pin must be tied to one of the pins based on the configuration options selected. They should not be left floating.</p>
F9	60	81	CONFIG[4]	I	CONFIG[4] pin configures HWCFG_MODE[2:0] options.
G9	59	80	CONFIG[5]	I	CONFIG[5] pin configures DIS_FC, DIS_SLEEP, and HWCFG_MODE[3] options.
G8	58	79	CONFIG[6]	I	CONFIG[6] pin configures SEL_TWSI, INT_POL, and 75/50 OHM options.
H8	56	77	SEL_FREQ		<p>Frequency Selection for XTAL1 input</p> <p>NC = Selects 25 MHz clock input.</p> <p>Tied low = Selects 125 MHz clock input.</p> <p>Internally divided to 25 MHz. SEL_FREQ is internally pulled up.</p>
H9	55	76	XTAL1	I	Reference Clock. 25 MHz \pm 50 ppm or 125 MHz \pm 50 ppm oscillator input. PLL clocks are not recommended.
J9	54	75	XTAL2	0	Reference Clock. 25 MHz \pm 50 ppm tolerance crystal reference. When the XTAL2 pin is not connected, it should be left floating. There is no option for a 125 MHz crystal. See "Crystal Oscillator" Application Note for details.

Table 12: Clock/Configuration/Reset//O (Continued)

117-TFBGA Pin #	96-BCC Pin #	128-PQFP Pin #	Pin Name	Pin Type	Description
K3	28	36	RESETn	I	Hardware reset. Active low. XTAL1 must be active for a minimum of 10 clock cycles before the rising edge of RESETn. RESETn must be pulled high for normal operation.
L4	27	37	COMA	I	<p>COMA disables all active circuitry to draw absolute minimum power. The COMA power mode can be activated by asserting high on the COMA pin. To deactivate the COMA power mode, tie the COMA pin low. Upon deactivating COMA mode, the 88E1111 device will continue normal operation.</p> <p>The COMA power mode cannot be enabled as long as hardware reset is enabled.</p> <p>In COMA mode, the PHY cannot wake up on its own by detecting activity on the CAT 5 cable.</p>



Table 13: Test

117-TFBGA Pin #	96-BCC Pin #	128-PQFP Pin #	Pin Name	Pin Type	Description
M5 M6	37 38	53 54	HSDAC+ HSDAC-	Analog PD	Test pins. These pins should be left floating but brought out for probing.

Table 14: Control and Reference

117-TFBGA Pin #	96-BCC Pin #	128-PQFP Pin #	Pin Name	Pin Type	Description
M2	30	39	RSET	Analog I	Constant voltage reference. External 5.0 kohm 1% resistor connection to VSS required for each pin.

Table 15: Power & Ground

117-TFBGA Pin #	96-BCC Pin #	128-PQFP Pin #	Pin Name	Pin Type	Description
B7 M3 M4 M7 M8 N5	32 35 36 40 45 78	44 49 52 59 64 104	AVDD	Power	Analog Power. 2.5V.
C6 C7 D7 E3 E7 F3 J3 J7	1 6 10 15 57 62 67 71 85	2 6 12 17 23 27 78 85 90 96 117 118	DVDD	Power	Digital Power. 1.0V (Instead of 1.0V, 1.2V can be used).
B9 F7 J8	52 66 72	73 89 97	VDDOH	Power	2.5V Power Supply for LED and CONFIG pins.
K9 L2	26 48	34 71	VDDOX	Power	2.5V Supply for the MDC/MDIO, INTn, 125CLK, RESETn, JTAG pin Power.
B4 C2 K1	5 21 88 96	5 11 30 122	VDDO	Power	2.5V I/O supply for the MAC interface pins.



Table 15: Power & Ground (Continued)

117-TFBGA Pin #	96-BCC Pin #	128-PQFP Pin #	Pin Name	Pin Type	Description
D4 D5 D6 E4 E5 E6 F4 F5 F6 G4 G5 G6 H4 H5 H6 J4 J5 J6 K4 K5 K6 L5 L6	0	1 9 15 21 22 38 40 43 45 48 51 55 58 60 63 65 66 83 84 93 94 101 102 103 106 108 111 116 119 127	VSS	GND	Global ground
H7	53	74	VSSC	GND	Ground reference for XTAL1 and XTAL2 pins. This pin must be connected to the ground.
G1 K7	13 51	50	NC	NC	No connect. Do not connect these pins to anything

1.5 I/O State at Various Test or Reset Modes

Pin(s)	Isolate	Loopback or Normal operation	Software Reset	Hardware Reset	Power Down	Coma	Power Down and Isolate
MDI[3:0]±	Active	Active	Tri-state	Tri-state	Tri-state	Tri-state	Tri-state
TX_CLK	Tri-state	Active	Reg. 16.3 state 0 = Low 1 = Active	Low	Reg. 16.3 state 0 = Low 1 = Active	Reg. 16.3 state 0 = Low 0 = Static but can be either high or low	Tri-state
RXD[0], RXD[2]	Tri-state	Active	High	High	High	High	Tri-state
RXD[7:3,1], RX_DV, RX_ER, CRS	Tri-state	Active	Low	Low	Low	Low	Tri-state
COL	Tri-state	TBI mode - input else -active	Tri-state	Tri-state	TBI mode - input else - low	TBI mode - input else - low	Tri-state
RX_CLK	Tri-state	Active	Reg. 16.3 state 0 = Low 1 = Active	Low	Reg. 16.3 state 0 = Low 1 = Active	Reg. 16.3 state 0 = Low 0 = Static but can be either high or low	Tri-state
S_CLK± S_OUT±	Active	Active	Tri-state	Tri-state	Reg. 16.3 state 0 = Tri-state 1 = Active	Tri-state	Active
MDIO	Active	Active	Active	Tri-state	Active	Tri-state	Active
INT	Active	Active	Tri-state	Tri-state	Tri-state	Tri-state	Tri-state
LED_***	Active	Active	High	High	High	High	High
TDO	Tri-state	Tri-state	Tri-state	Tri-state	Tri-state	Active	Tri-state
125CLK	Reg. 16.4 state 0 = Toggle 1 = Low	Reg. 16.4 state 0 = Toggle 1 = Low	Reg. 16.4 state 0 = Toggle 1 = Low	Toggle	Reg. 16.4 state 0 = Toggle 1 = Low	Reg. 16.3 state 0 = Static but can be either high or low 0 = Low	Reg. 16.4 state 0 = Toggle 1 = Low



1.6 117-Pin TFBGA Pin Assignment List - Alphabetical by Signal Name

Pin #	Pin Name	Pin #	Pin Name
K2	125CLK	A9	LED_LINK1000
B7	AVDD	C9	LED_RX
M3	AVDD	D9	LED_TX
M4	AVDD	L3	MDC
M7	AVDD	N2	MDI[0]-
M8	AVDD	N1	MDI[0]+
N5	AVDD	N4	MDI[1]-
B6	COL	N3	MDI[1]+
L4	COMA	N7	MDI[2]-
D8	CONFIG[0]	N6	MDI[2]+
E9	CONFIG[1]	N9	MDI[3]-
F8	CONFIG[2]	N8	MDI[3]+
G7	CONFIG[3]	M1	MDIO
F9	CONFIG[4]	G1	NC
G9	CONFIG[5]	K7	NC
G8	CONFIG[6]	K3	RESETn
B5	CRS	M2	RSET
C6	DVDD	B2	RXD0
C7	DVDD	D3	RXD1
D7	DVDD	C3	RXD2
E3	DVDD	B3	RXD3
E7	DVDD	C4	RXD4
F3	DVDD	A1	RXD5
J3	DVDD	A2	RXD6
J7	DVDD	C5	RXD7
E2	GTX_CLK	C1	RX_CLK
M6	HSDAC-	B1	RX_DV
M5	HSDAC+	D2	RX_ER
L1	INTn	A6	S_CLK-
E8	LED_DUPLEX	A5	S_CLK+
C8	LED_LINK10	A4	S_IN-
B8	LED_LINK100	A3	S_IN+

1.6 117-Pin TFBGA Pin Assignment List - Alphabetical by Signal Name (Continued)

Pin #	Pin Name	Pin #	Pin Name
A8	S_OUT-	D4	VSS
A7	S_OUT+	D5	VSS
H8	SEL_FREQ	D6	VSS
L9	TCK	E4	VSS
L7	TDI	E5	VSS
K8	TDO	E6	VSS
L8	TMS	F4	VSS
M9	TRSTn	F5	VSS
F1	TXD0	F6	VSS
G2	TXD1	G4	VSS
G3	TXD2	G5	VSS
H2	TXD3	G6	VSS
H1	TXD4	H4	VSS
H3	TXD5	H5	VSS
J1	TXD6	H6	VSS
J2	TXD7	J4	VSS
D1	TX_CLK	J5	VSS
E1	TX_EN	J6	VSS
F2	TX_ER	K4	VSS
B4	VDDO	K5	VSS
C2	VDDO	K6	VSS
K1	VDDO	L5	VSS
B9	VDDOH	L6	VSS
F7	VDDOH	H7	VSSC
J8	VDDOH	H9	XTAL1
K9	VDDOX	J9	XTAL2
L2	VDDOX		



1.7 96-Pin BCC Pin Assignment List - Alphabetical by Signal Name

Pin #	Pin Name	Pin #	Pin Name
22	125CLK	74	LED_LINK100
32	AVDD	73	LED_LINK1000
35	AVDD	69	LED_RX
36	AVDD	68	LED_TX
40	AVDD	25	MDC
45	AVDD	31	MDI[0]-
78	AVDD	29	MDI[0]+
83	COL	34	MDI[1]-
27	COMA	33	MDI[1]+
65	CONFIG[0]	41	MDI[2]-
64	CONFIG[1]	39	MDI[2]+
63	CONFIG[2]	43	MDI[3]-
61	CONFIG[3]	42	MDI[3]+
60	CONFIG[4]	24	MDIO
59	CONFIG[5]	13	NC
58	CONFIG[6]	51	NC
84	CRS	28	RESETn
1	DVDD	30	RSET
6	DVDD	95	RXD0
10	DVDD	92	RXD1
15	DVDD	93	RXD2
57	DVDD	91	RXD3
62	DVDD	90	RXD4
67	DVDD	89	RXD5
71	DVDD	87	RXD6
85	DVDD	86	RXD7
8	GTX_CLK	2	RX_CLK
38	HSDAC-	94	RX_DV
37	HSDAC+	3	RX_ER
23	INTn	80	S_CLK-
70	LED_DUPLEX	79	S_CLK+
76	LED_LINK10	81	S_IN-

1.7 96-Pin BCC Pin Assignment List - Alphabetical by Signal Name (Continued)

Pin #	Pin Name	Pin #	Pin Name
82	S_IN+	4	TX_CLK
75	S_OUT-	9	TX_EN
77	S_OUT+	7	TX_ER
56	SEL_FREQ	5	VDDO
49	TCK	21	VDDO
44	TDI	88	VDDO
50	TDO	96	VDDO
46	TMS	52	VDDOH
47	TRSTn	66	VDDOH
11	TXD0	72	VDDOH
12	TXD1	26	VDDOX
14	TXD2	48	VDDOX
16	TXD3	0	VSS
17	TXD4	53	VSSC
18	TXD5	55	XTAL1
19	TXD6	54	XTAL2
20	TXD7		



1.8 128-Pin PQFP Pin Assignment List - Alphabetical by Signal Name

Pin #	Pin Name	Pin #	Pin Name
31	125CLK	32	INTn
44	AVDD	95	LED_DUPLEX
49	AVDD	100	LED_LINK10
52	AVDD	99	LED_LINK100
59	AVDD	98	LED_LINK1000
64	AVDD	92	LED_RX
104	AVDD	91	LED_TX
114	COL	35	MDC
37	COMA	41	MDI[0]+
88	CONFIG[0]	42	MDI[0]-
87	CONFIG[1]	46	MDI[1]+
86	CONFIG[2]	47	MDI[1]-
82	CONFIG[3]	56	MDI[2]+
81	CONFIG[4]	57	MDI[2]-
80	CONFIG[5]	61	MDI[3]+
79	CONFIG[6]	62	MDI[3]-
115	CRS	33	MDIO
2	DVDD	50	NC
6	DVDD	36	RESETn
12	DVDD	39	RSET
17	DVDD	7	RX_CLK
23	DVDD	4	RX_DV
27	DVDD	8	RX_ER
78	DVDD	3	RXD0
85	DVDD	128	RXD1
90	DVDD	126	RXD2
96	DVDD	125	RXD3
117	DVDD	124	RXD4
118	DVDD	123	RXD5
14	GTX_CLK	121	RXD6
53	HSDAC+	120	RXD7
54	HSDAC-	110	S_CLK+

1.8 128-Pin PQFP Pin Assignment List - Alphabetical by Signal Name (Continued)

Pin #	Pin Name	Pin #	Pin Name
109	S_CLK-	9	VSS
113	S_IN+	15	VSS
112	S_IN-	21	VSS
107	S_OUT+	22	VSS
105	S_OUT-	38	VSS
77	SEL_FREQ	40	VSS
70	TCK	43	VSS
67	TDI	45	VSS
72	TDO	48	VSS
69	TMS	51	VSS
68	TRSTn	55	VSS
10	TX_CLK	58	VSS
16	TX_EN	60	VSS
13	TX_ER	63	VSS
18	TXD0	65	VSS
19	TXD1	66	VSS
20	TXD2	83	VSS
24	TXD3	84	VSS
25	TXD4	93	VSS
26	TXD5	94	VSS
28	TXD6	101	VSS
29	TXD7	102	VSS
5	VDDO	103	VSS
11	VDDO	106	VSS
30	VDDO	108	VSS
122	VDDO	111	VSS
73	VDDOH	116	VSS
89	VDDOH	119	VSS
97	VDDOH	127	VSS
34	VDDOX	74	VSSC
71	VDDOX	76	XTAL1
1	VSS	75	XTAL2

Section 2. Package Mechanical Dimensions

2.1 117-pin TFBGA Package

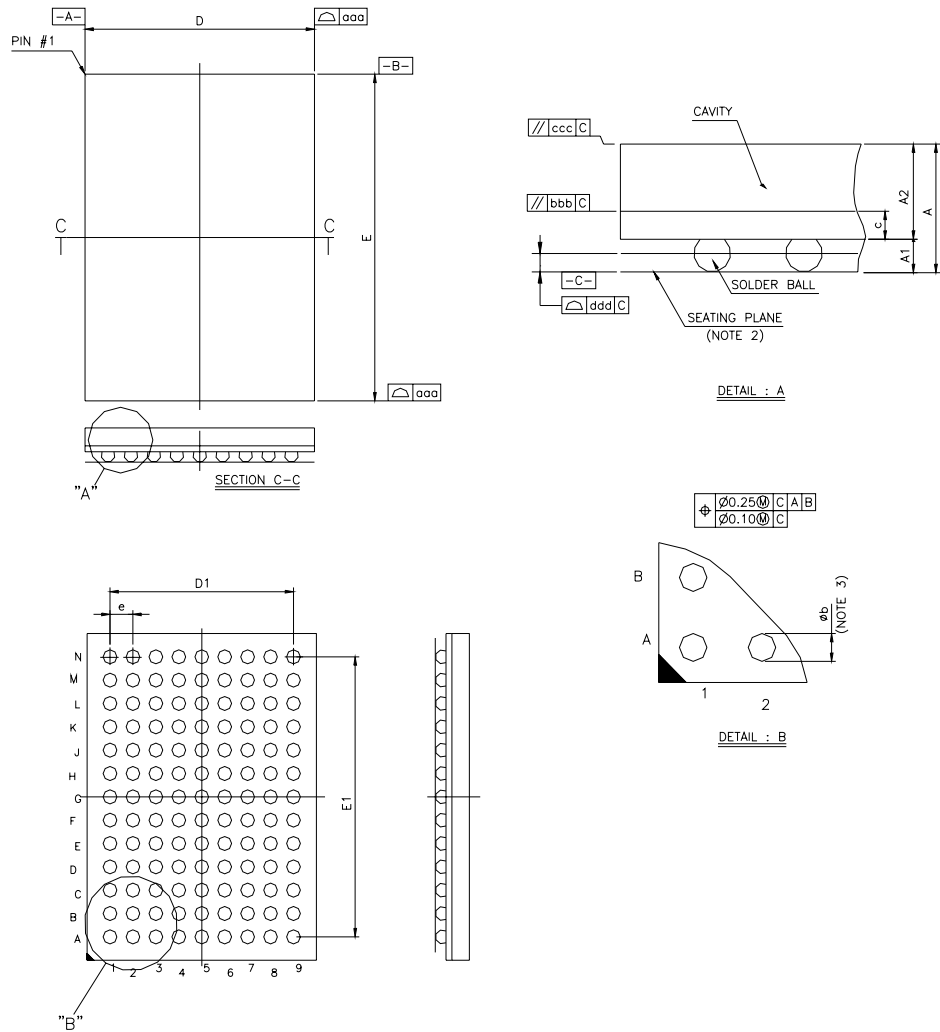

(All dimensions in mm.)

Table 16: 117-Pin TFBGA Package Dimensions

Dimensions in mm			
Symbol	MIN	NOM	MAX
A	--	--	1.54
A1	0.40	0.50	0.60
A2	0.84	0.89	0.94
c	0.32	0.36	0.40
D	9.90	10.00	10.10
E	13.90	14.00	14.10
D1	--	8.00	--
E1	--	12.00	--
e	--	1.00	--
b	0.50	0.60	0.70
aaa	0.20		
bbb	0.25		
ccc	0.35		
ddd	0.15		
MD/ME			

NOTE:

1. CONTROLLING DIMENSION: MILLIMETER.
2. PRIMARY DATUM C AND SEATING PLANE ARE DEFINED BY THE SPHERICAL CROWNS OF THE SOLDER BALLS.
3. DIMENSION b IS MEASURED AT THE MAXIMUM SOLDER BALL DIAMETER, PARALLEL TO PRIMARY DATUM C.

2.2 96-pin BCC Package - Top View

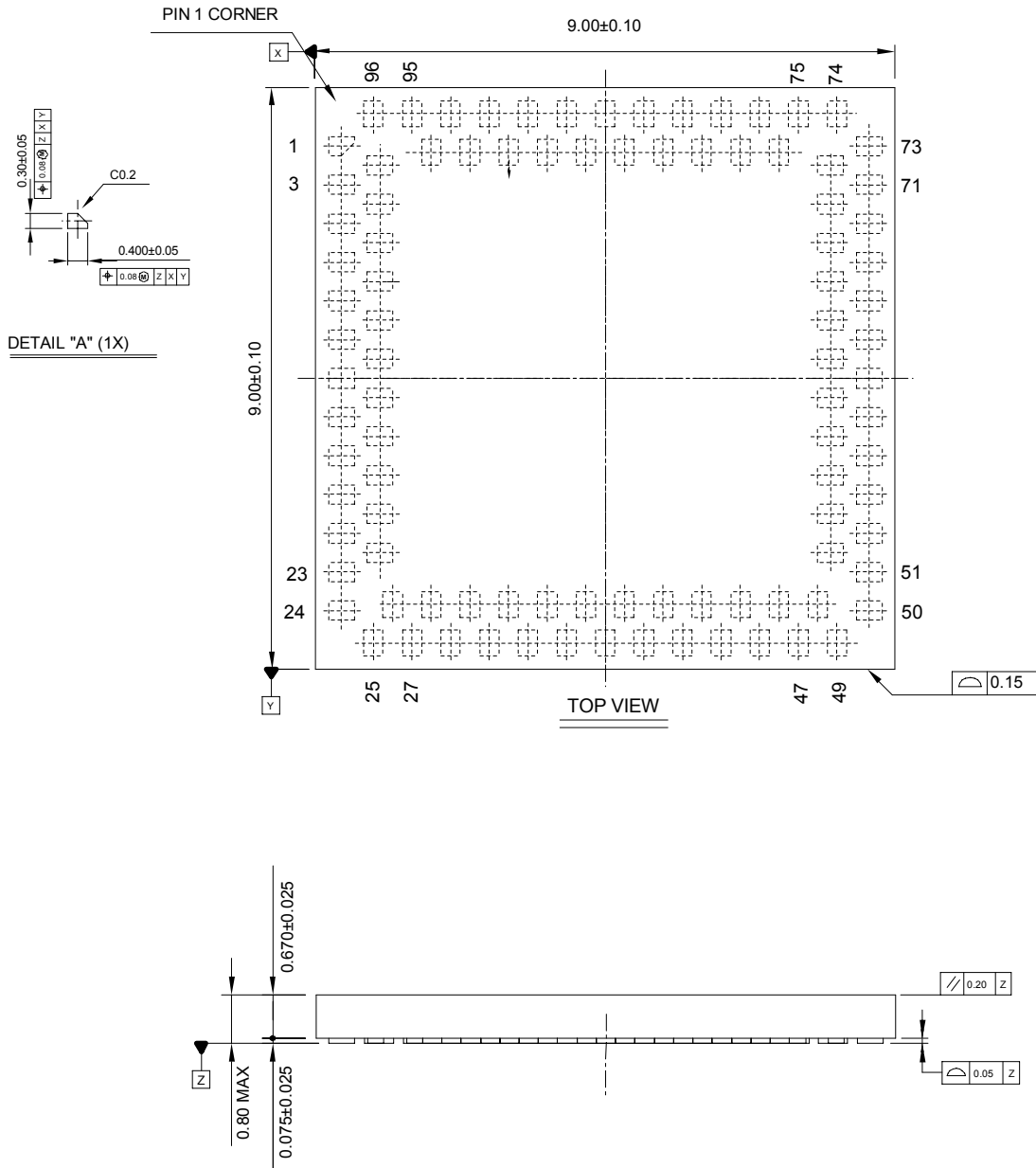

2.3 96-Pin BCC Package - Bottom View

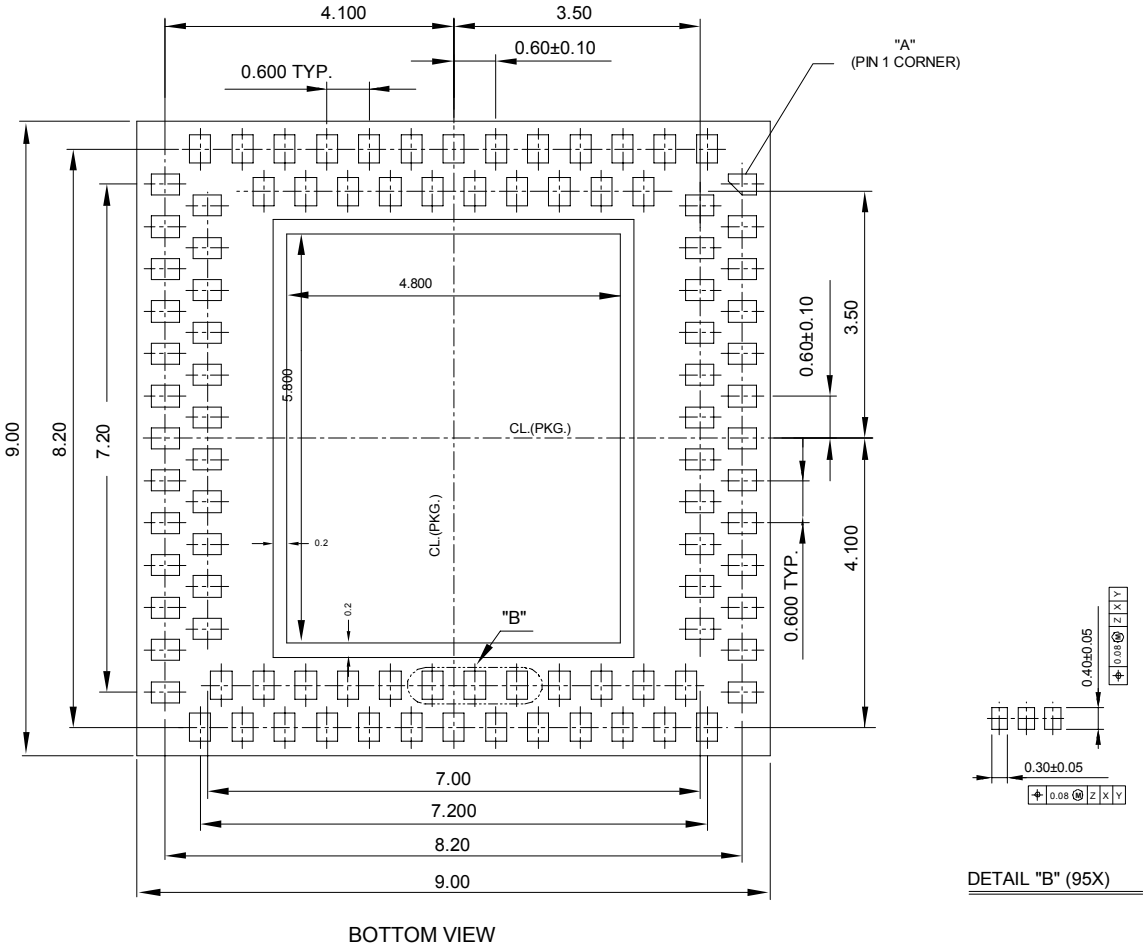

2.4 128-Pin PQFP Package

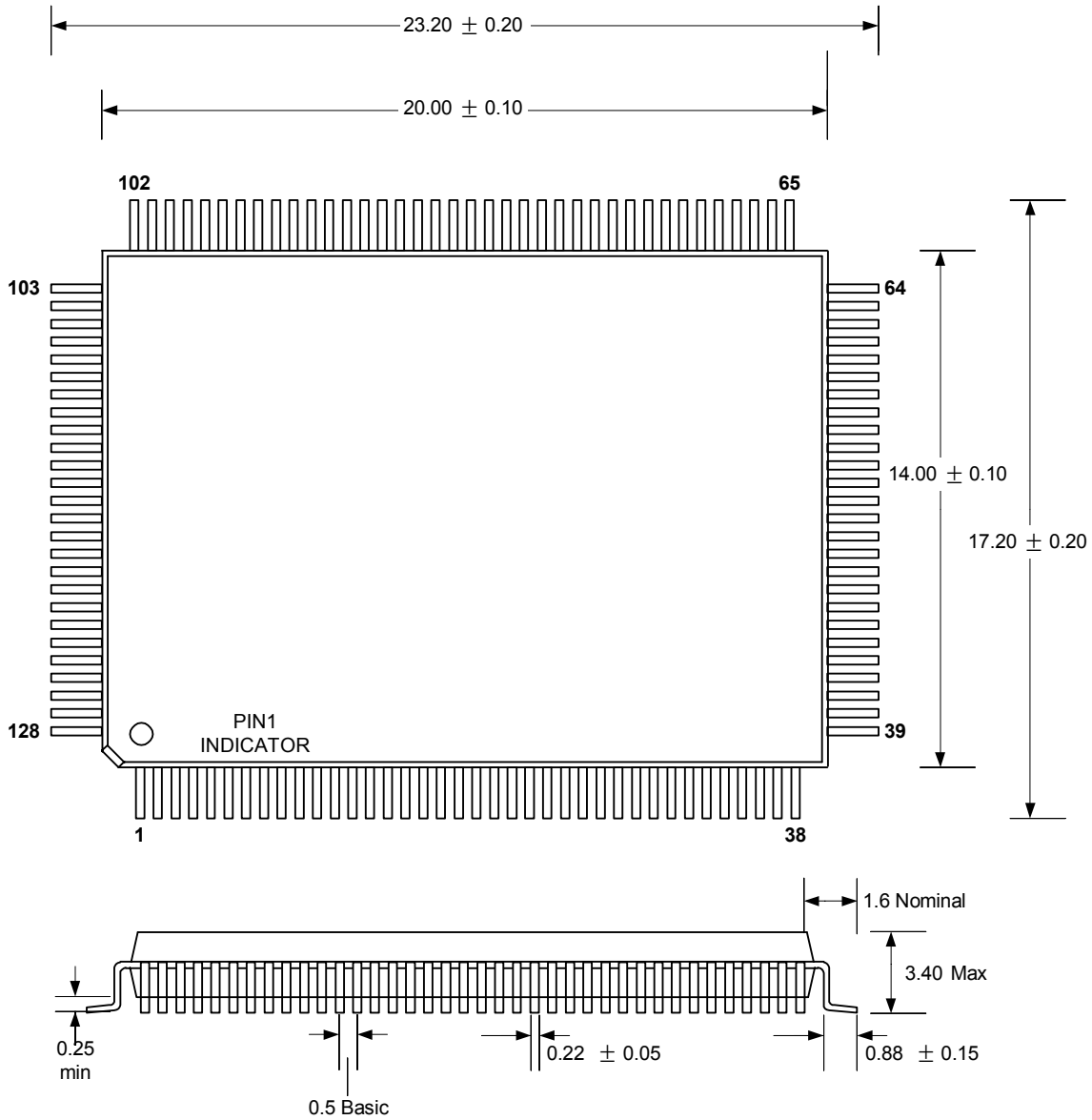

Section 3. Order Information

3.1 Ordering Part Numbers and Package Markings

Figure 5 shows the ordering part numbering scheme for the 88E1111 devices. Contact Marvell® FAEs or sales representatives for complete ordering information.

Figure 5: Sample Part Number

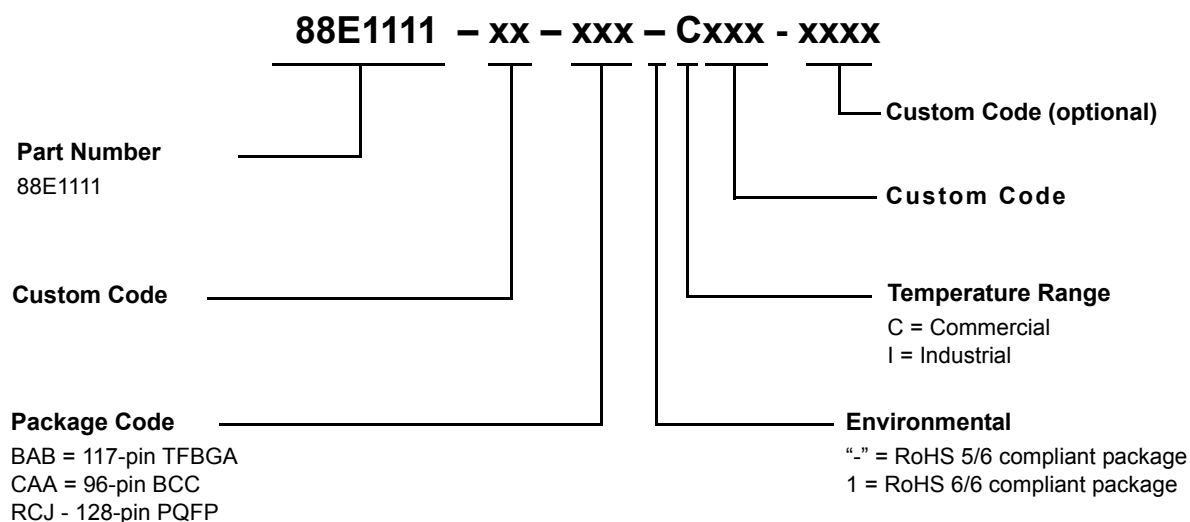

Table 17: 88E1111 Part Order Options - RoHS 5/6 Compliant Package

Package Type	Part Order Number
88E1111 117-pin TFBGA - Commercial	88E1111-XX-BAB-C000
88E1111 117-pin TFBGA - Industrial	88E1111-XX-BAB-I000
88E1111 96-pin BCC - Commercial	88E1111-XX-CAA-C000
88E1111 96-pin BCC - Industrial	88E1111-XX-CAA-I000
88E1111 128-pin PQFP - Commercial	88E1111-XX-RCJ-C000

Table 18: 88E1111 Part Order Options - RoHS 6/6 Compliant Package

Package Type	Part Order Number
88E1111 117-pin TFBGA - Commercial	88E1111-XX-BAB1C000
88E1111 117-pin TFBGA - Industrial	88E1111-XX-BAB1I000
88E1111 96-pin BCC - Commercial	88E1111-XX-CAA1C000
88E1111 96-pin BCC - Industrial	88E1111-XX-CAA1I000
88E1111 128-pin PQFP - Commercial	88E1111-XX-RCJ1C000

3.1.1 RoHS 5/6 Compliant Marking Examples

Figure 6 is an example of the package marking and pin 1 location for the 88E1111 117-pin TFBGA commercial RoHS 5/6 compliant package.

Figure 6: 88E1111 117-pin TFBGA Commercial RoHS 5/6 Compliant Package Marking and Pin 1 Location

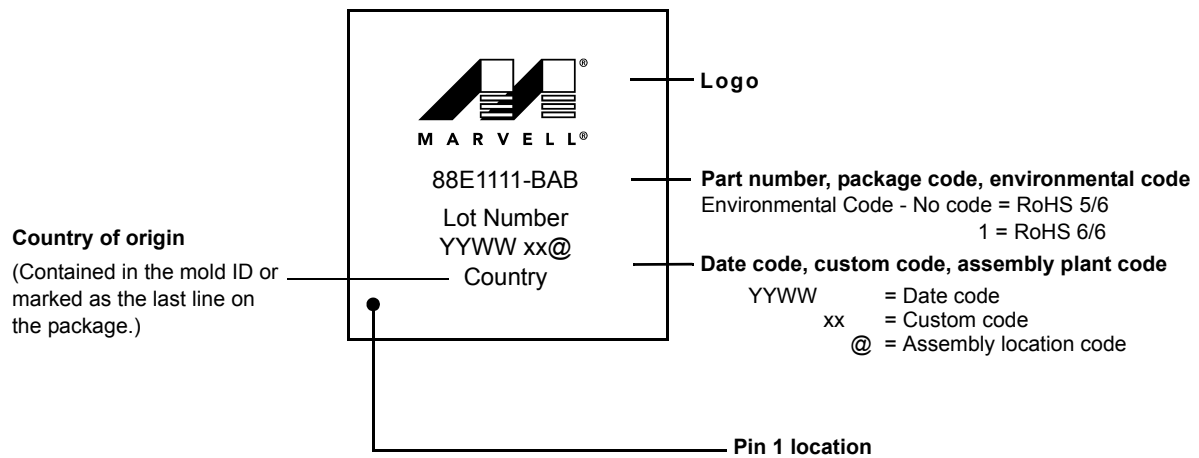

Note: The above example is not drawn to scale. Location of markings is approximate.

Figure 7 is an example of the package marking and pin 1 location for the 88E1111 117-pin TFBGA Industrial RoHS 5/6 compliant package.

Figure 7: 88E1111 117-pin TFBGA Industrial RoHS 5/6 Compliant Package Marking and Pin 1 Location

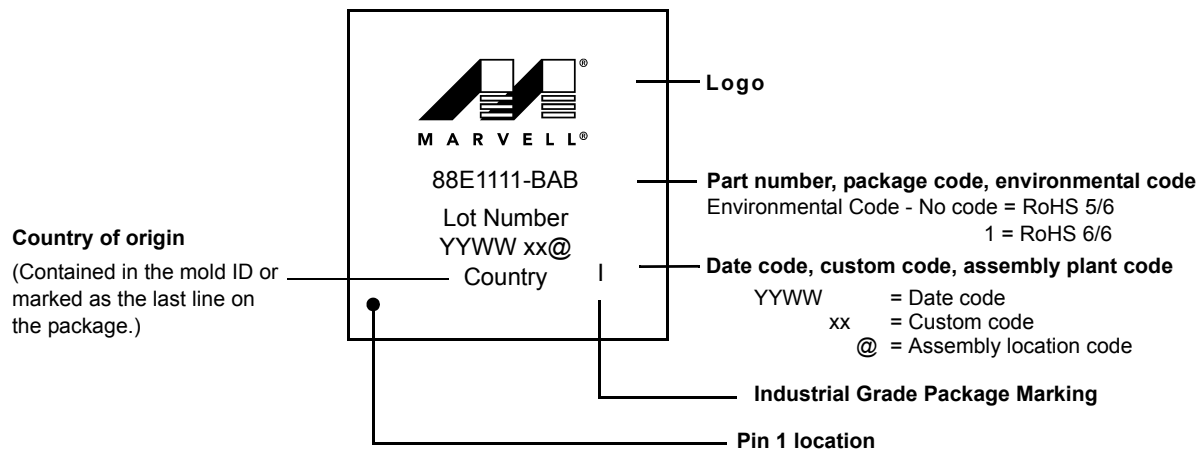

Note: The above example is not drawn to scale. Location of markings is approximate.

Figure 8 is an example of the package marking and pin 1 location for the 88E1111 96-pin BCC Commercial RoHS 5/6 compliant package.

Figure 8: 88E1111 96-pin BCC Commercial RoHS 5/6 Compliant Package Marking and Pin 1 Location

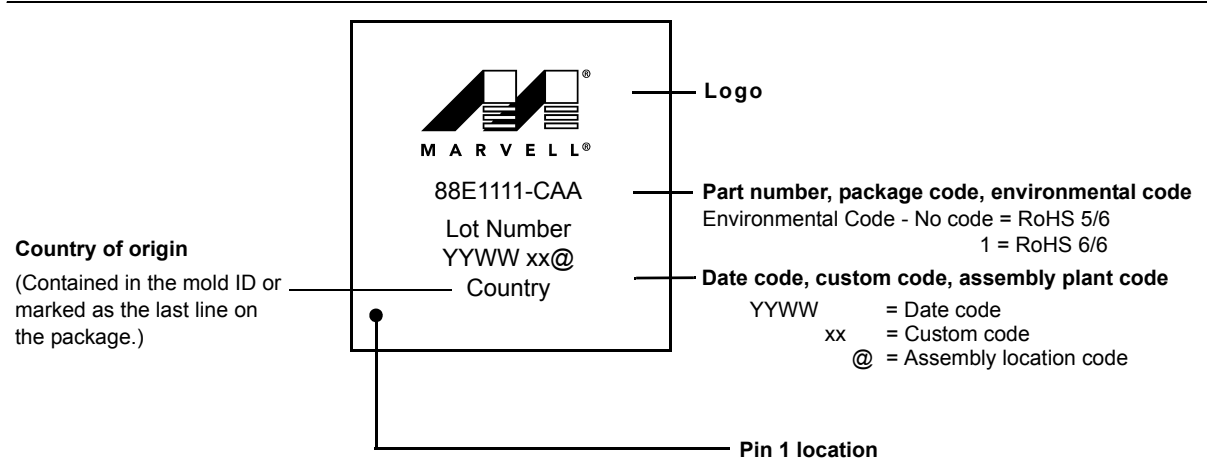

Note: The above example is not drawn to scale. Location of markings is approximate.

Figure 9 is an example of the package marking and pin 1 location for the 88E1111 96-pin BCC Industrial RoHS 5/6 compliant package.

Figure 9: 88E1111 96-pin BCC Industrial RoHS 5/6 Compliant Package Marking and Pin 1 Location

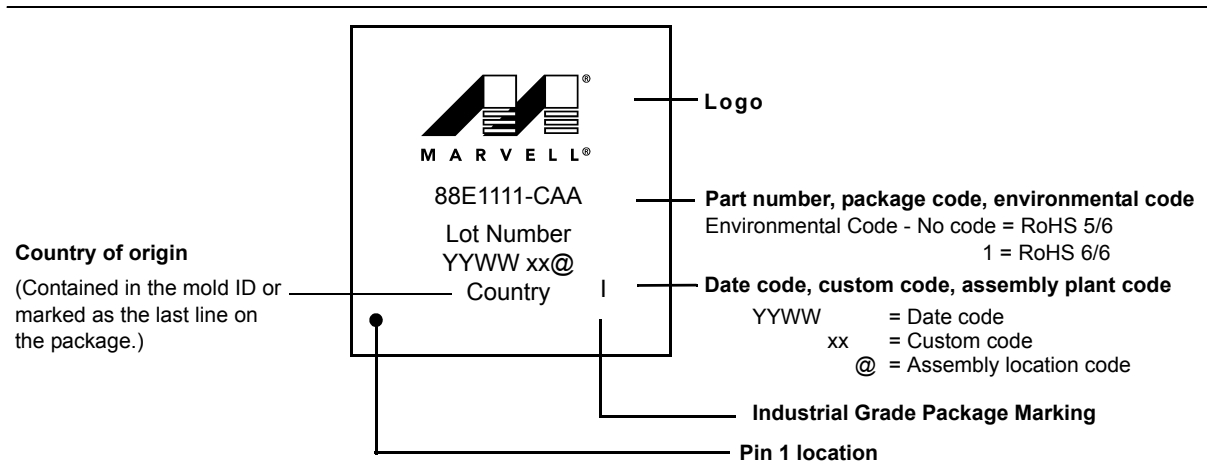

Note: The above example is not drawn to scale. Location of markings is approximate.

Figure 10 is an example of the package marking and pin 1 location for the 88E1111 128-pin PQFP Commercial RoHS 5/6 compliant package.

Figure 10: 88E1111 128-pin PQFP Commercial RoHS 5/6 Compliant Package Marking and Pin 1 Location

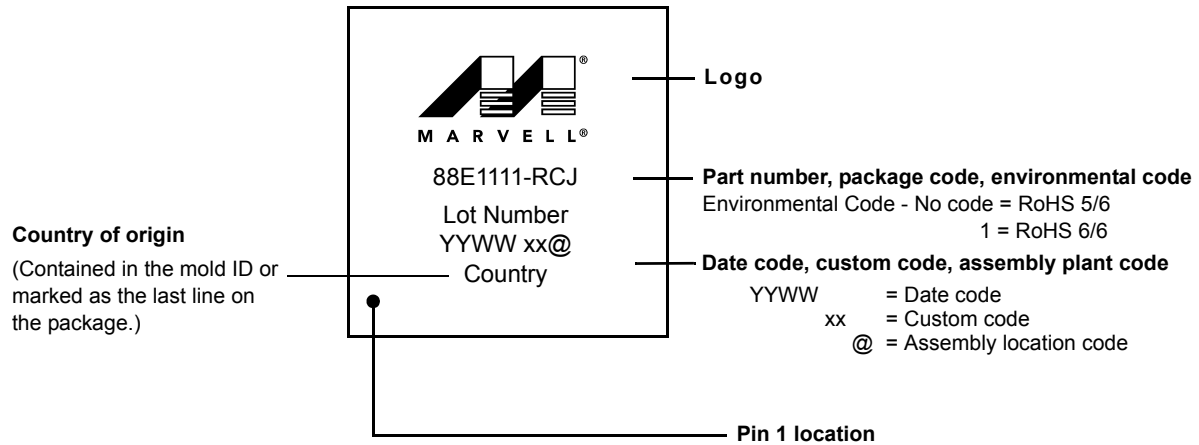

Note: The above example is not drawn to scale. Location of markings is approximate.

3.1.2 RoHS 6/6 Compliant Marking Examples

Figure 11 is an example of the package marking and pin 1 location for the 88E1111 117-pin TFBGA commercial RoHS 6/6 compliant package.

Figure 11: 88E1111 117-pin TFBGA Commercial RoHS 6/6 Compliant Package Marking and Pin 1 Location

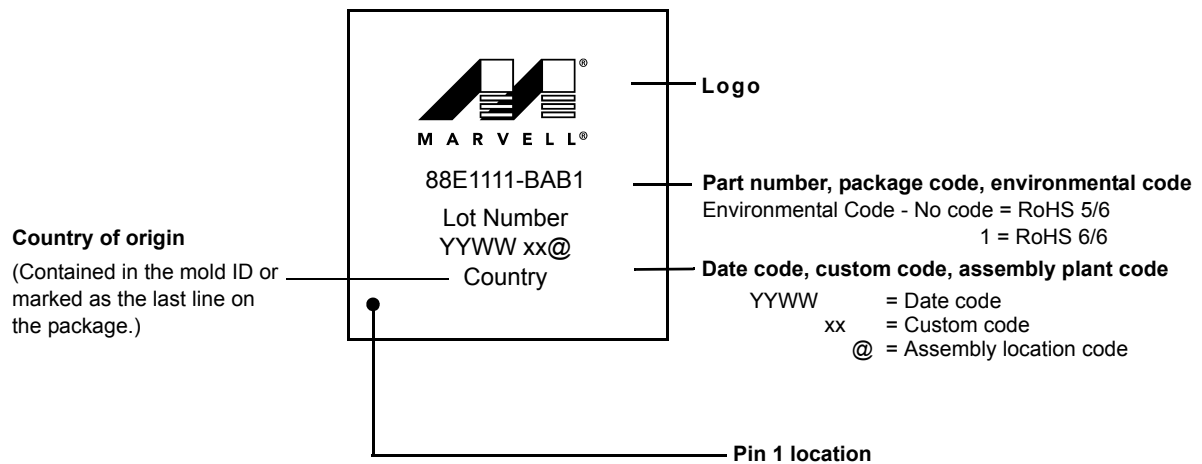

Note: The above example is not drawn to scale. Location of markings is approximate.

Figure 12 is an example of the package marking and pin 1 location for the 88E1111 117-pin TFBGA industrial RoHS 6/6 compliant package.

Figure 12: 88E1111 117-pin TFBGA Industrial RoHS 6/6 Compliant Package Marking and Pin 1 Location

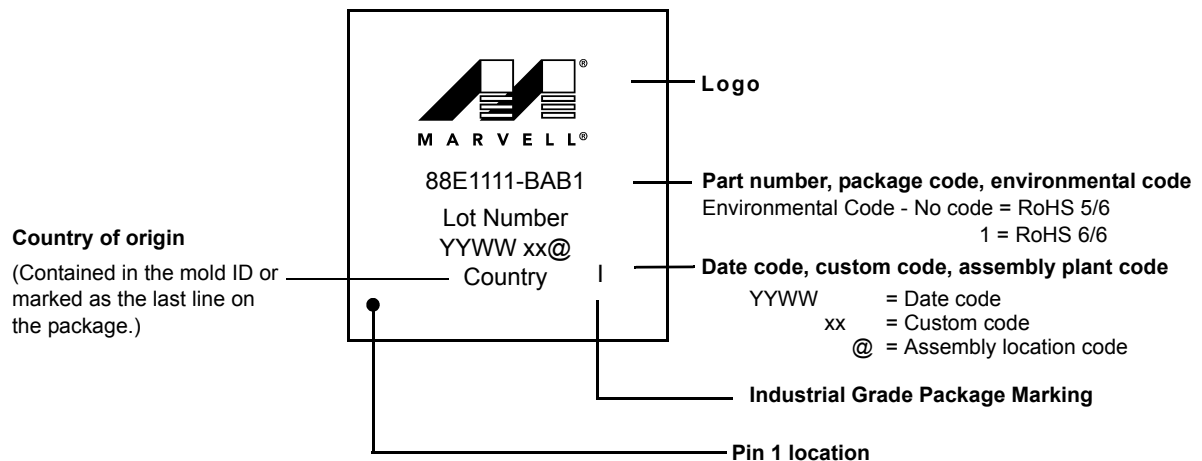

Note: The above example is not drawn to scale. Location of markings is approximate.



Figure 13 is an example of the package marking and pin 1 location for the 88E1111 96-pin BCC Commercial RoHS 6/6 compliant package.

Figure 13: 88E1111 96-pin BCC Commercial RoHS 6/6 Compliant Package Marking and Pin 1 Location

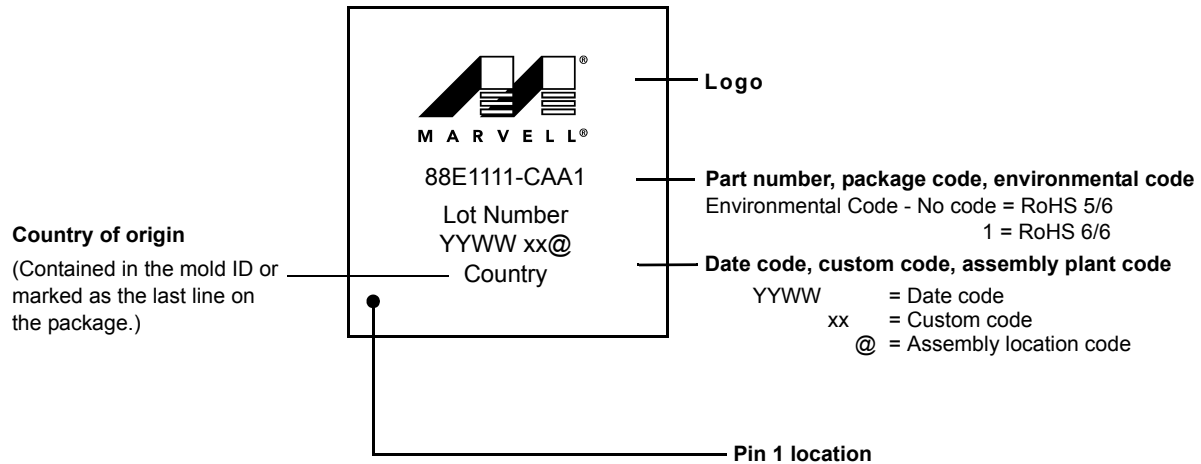

Note: The above example is not drawn to scale. Location of markings is approximate.

Figure 14 is an example of the package marking and pin 1 location for the 88E1111 96-pin BCC Industrial RoHS 6/6 compliant package.

Figure 14: 88E1111 96-pin BCC Industrial RoHS 6/6 Compliant Package Marking and Pin 1 Location

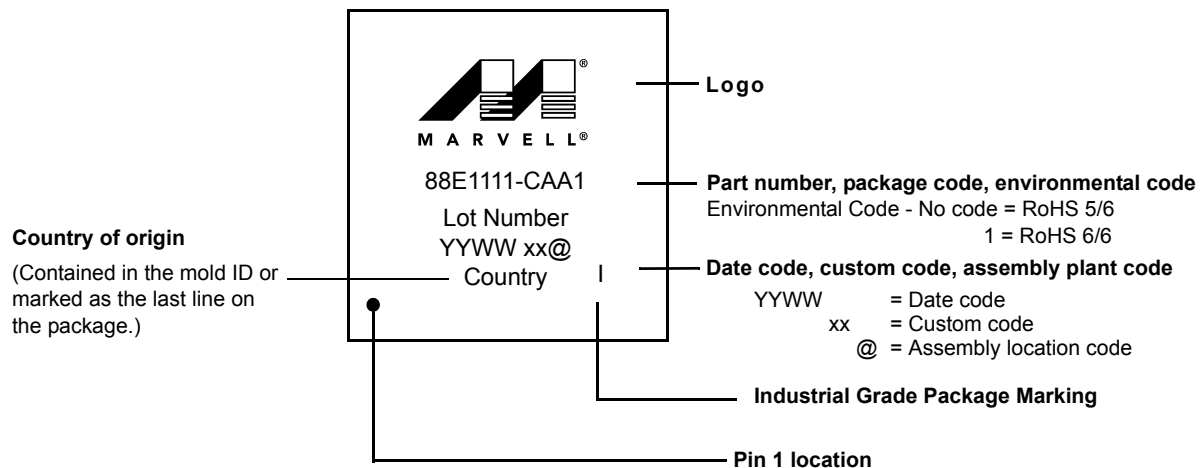

Note: The above example is not drawn to scale. Location of markings is approximate.

Figure 15 is an example of the package marking and pin 1 location for the 88E1111 128-pin PQFP Commercial RoHS 6/6 compliant package.

Figure 15: 88E1111 128-pin PQFP Commercial RoHS 6/6 Compliant Package Marking and Pin 1 Location

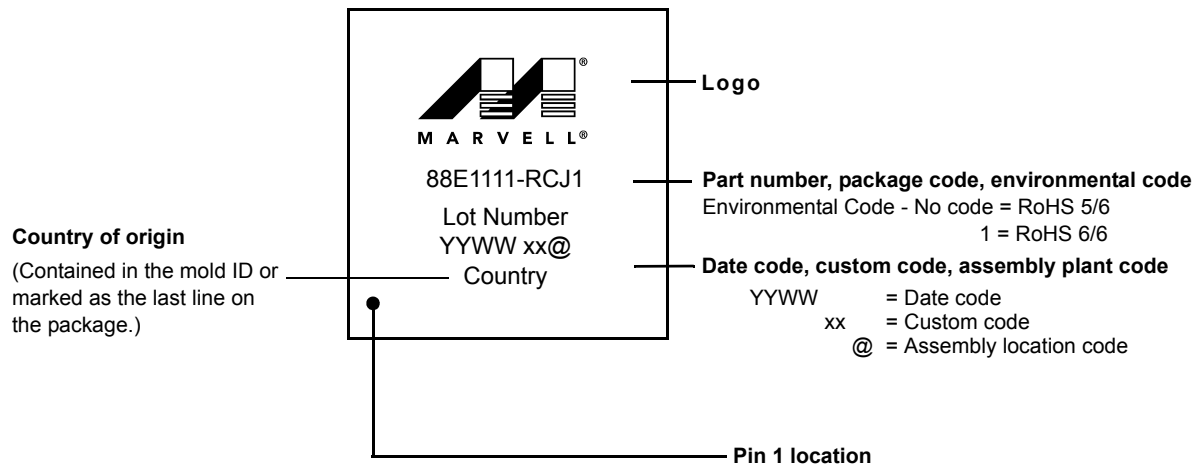

Note: The above example is not drawn to scale. Location of markings is approximate.



Marvell Semiconductor, Inc.
5488 Marvell Lane
Santa Clara, CA 95054, USA

Tel: 1.408.222.2500

Fax: 1.408.752.9028

www.marvell.com

Marvell. Moving Forward Faster